

City of Duluth 2026 Street Projects Overview

Public Informational Session
March 19, 2026



Background of Sales Tax Streets Program

- 55% of the City of Duluth's 450 miles of local streets are in "poor" condition
- The 1/2 Percent Sales Tax Program was passed in 2017 by Duluth's voters
- It generates approximately \$8 million/year for street preservation; this project uses about half
- 2019 – sales tax funding collection began
- 2020 - first year of sales tax projects

City of Duluth Sales Tax Street Project



Project Priority Setting

- What do we consider in picking projects?
 - Pavement conditions
 - Coordination with Utility Needs (water, storm water, etc)
 - Multi-modal needs – pedestrian, transit & micro-mobility
 - Safe Routes to Schools plans
 - Core Investment Areas (Imagine Duluth 2045 Plan)
 - Geographic Equity (City-wide project distribution)
- Deferred projects move to the top in the next year



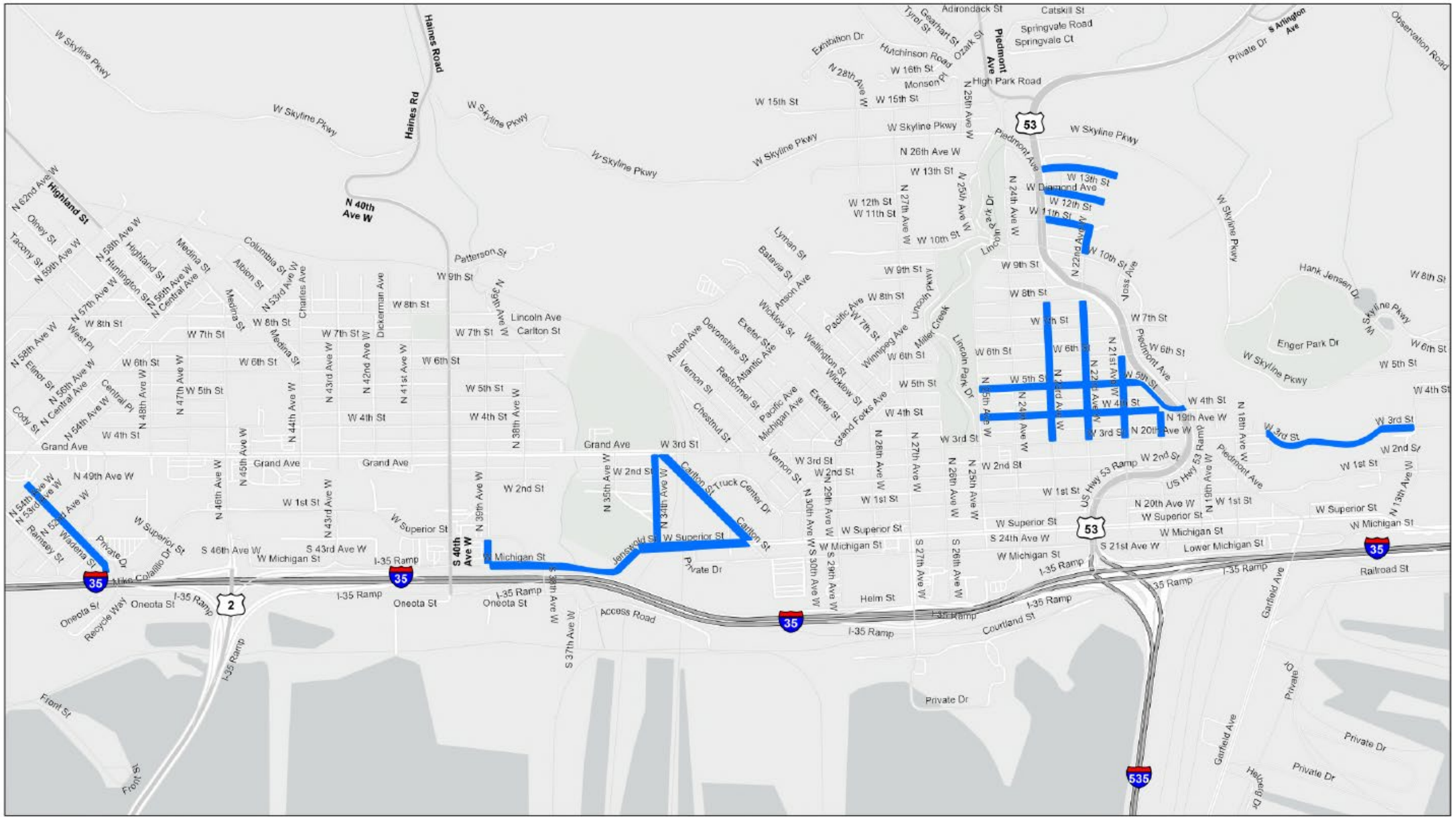

■ 2026 Sales Tax Projects

2026 Street Preservation City Proj No: 2317



The City of Duluth has used its best efforts to ensure that the information contained in this map or electronic document is accurate. The City of Duluth makes no warranty or guarantee concerning the accuracy or reliability of this information, and is not responsible for any errors or omissions. The information is provided for informational purposes only. The City of Duluth shall not be liable for errors or omissions. The information is provided for informational purposes only.

Date Created: 3/17/2026



■ 2026 Sales Tax Projects

2026 Street Preservation City Proj No: 2255



Date Created: 4/24/2025

The City of Duluth has tried to ensure that the information contained in this map or electronic document is accurate. The City of Duluth makes no warranty or guarantee concerning the accuracy or reliability. This document is neither a legally recorded map nor a survey and is not intended to be used as one. The drawings are a compilation of records, information and data located in various City, County and State offices and other sources affecting the area shown and are to be used for reference purposes only. The City of Duluth shall not be liable for errors contained within this data provided or for any damages in connection with the use of this information contained within.

Overview: Project Descriptions

- Overlay
- Mill and Overlay
- Reclaim
- ADA Improvements – Curb ramps

Overview: Overlays

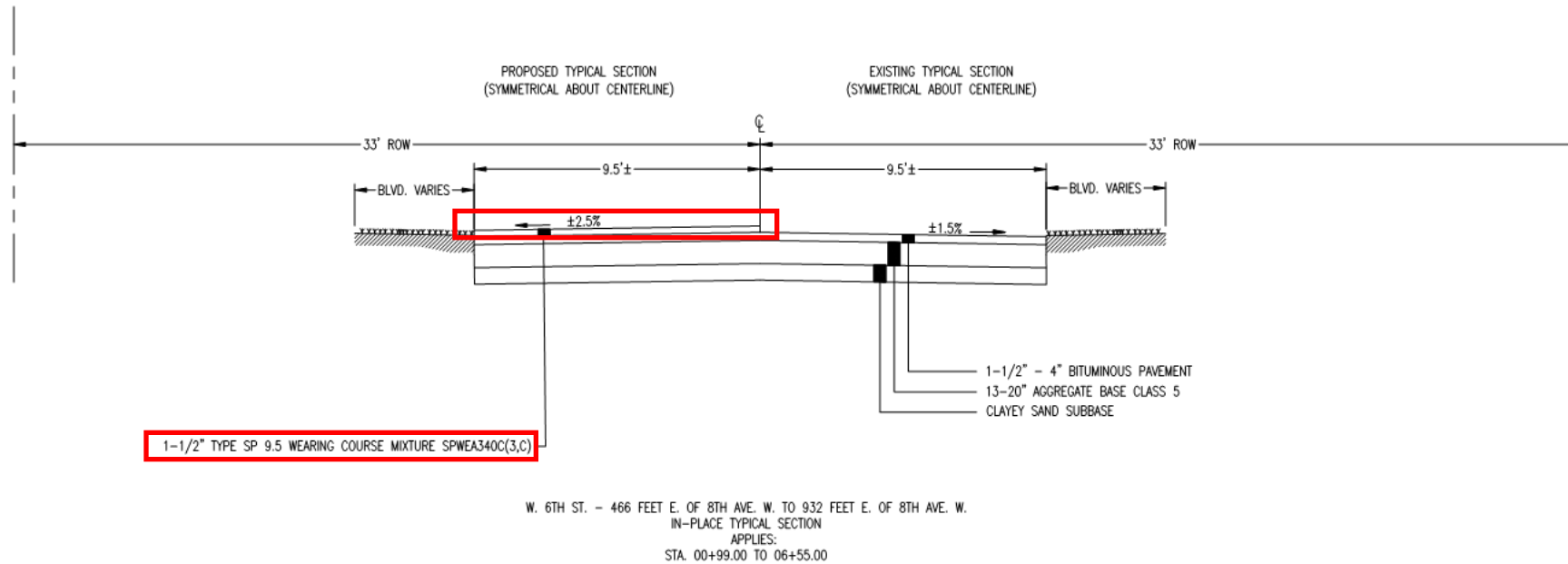

Overview: Mill & Overlays

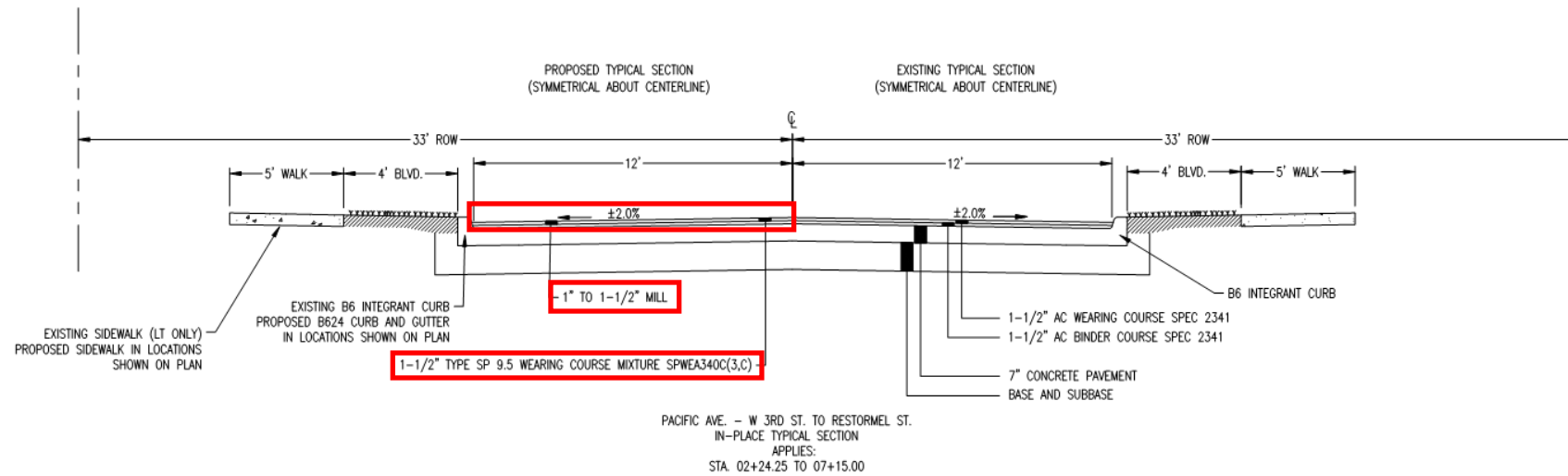

Overview: Reclaims

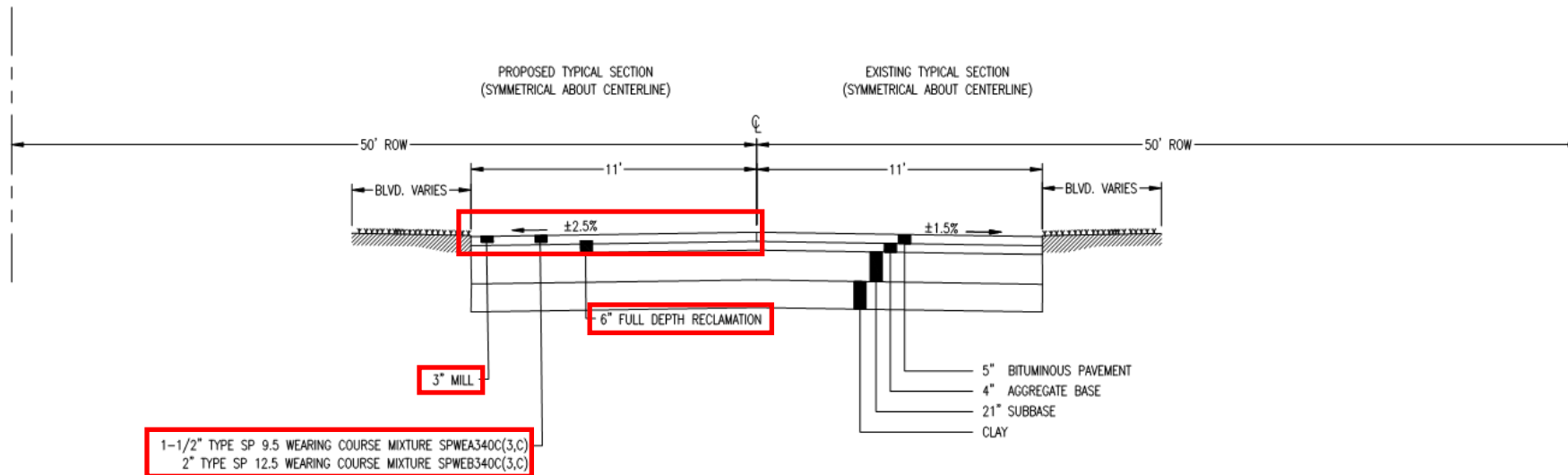

MEDINA ST. - N. 57TH AVE W. TO N. CENTRAL AVE
IN-PLACE TYPICAL SECTION
APPLIES:
STA. 01+20.50 TO 07+83.00

Overview: ADA Improvements

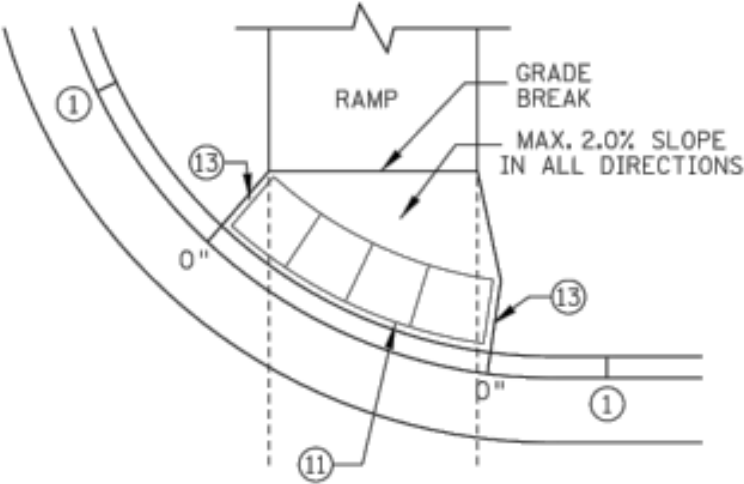
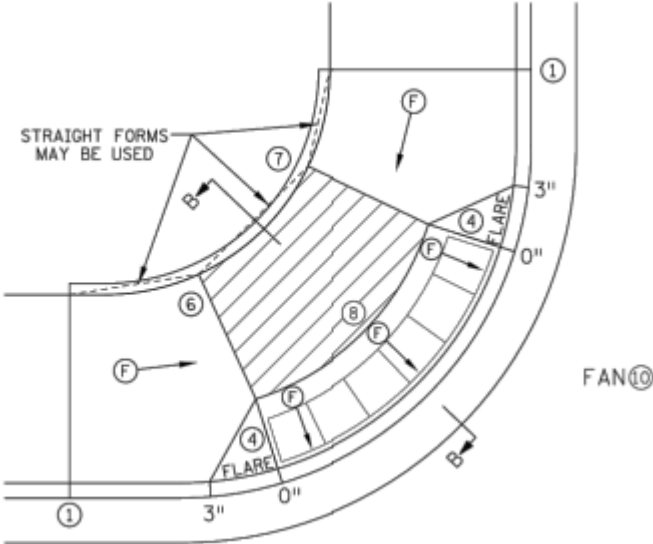

Access & Traffic Control During Construction

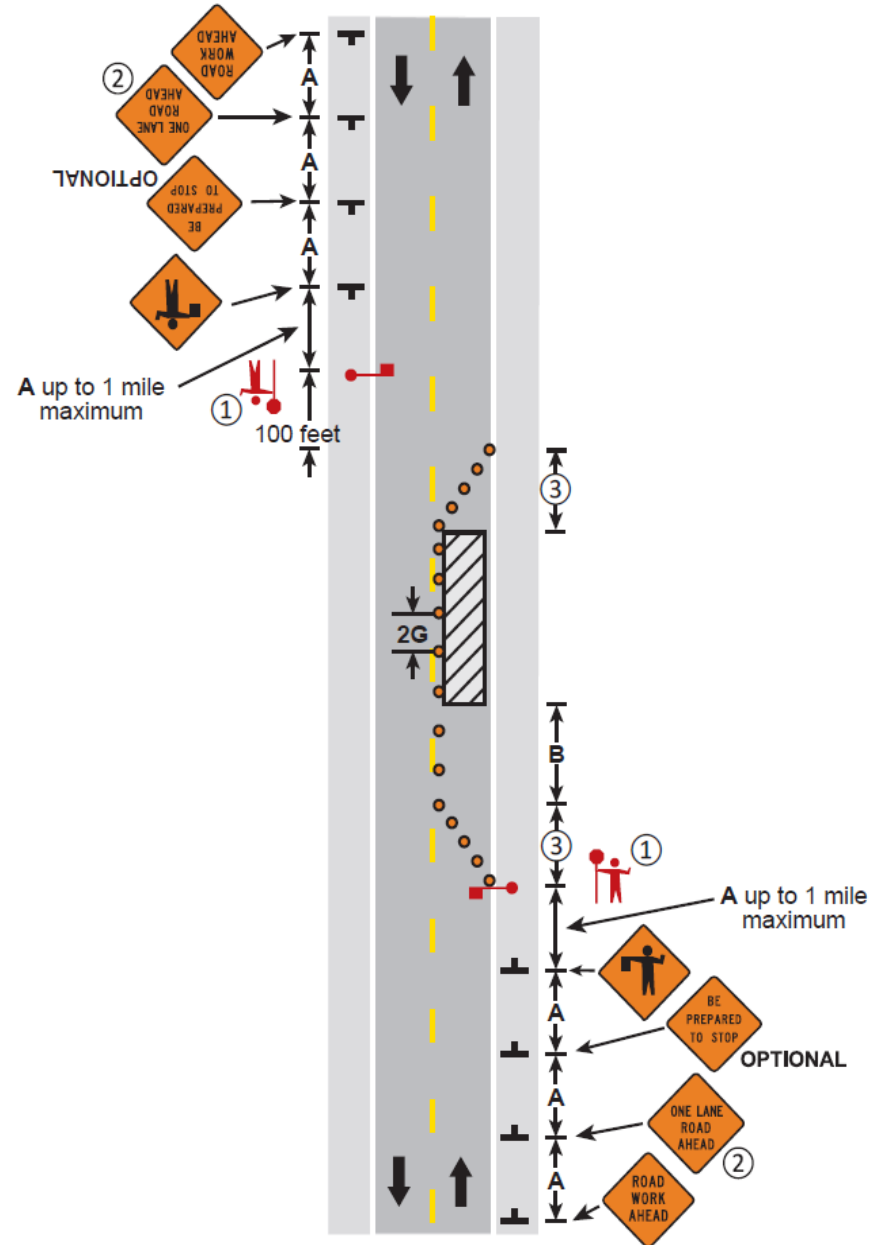

Program Schedule

- 90% Design January 2026
- Final Design February 2026
- Bidding February-March 2026
- Construction May-October 2026
 - Webpage updates weekly for specific street schedule

<https://duluthmn.gov/engineering/2026-sales-tax-projects/>



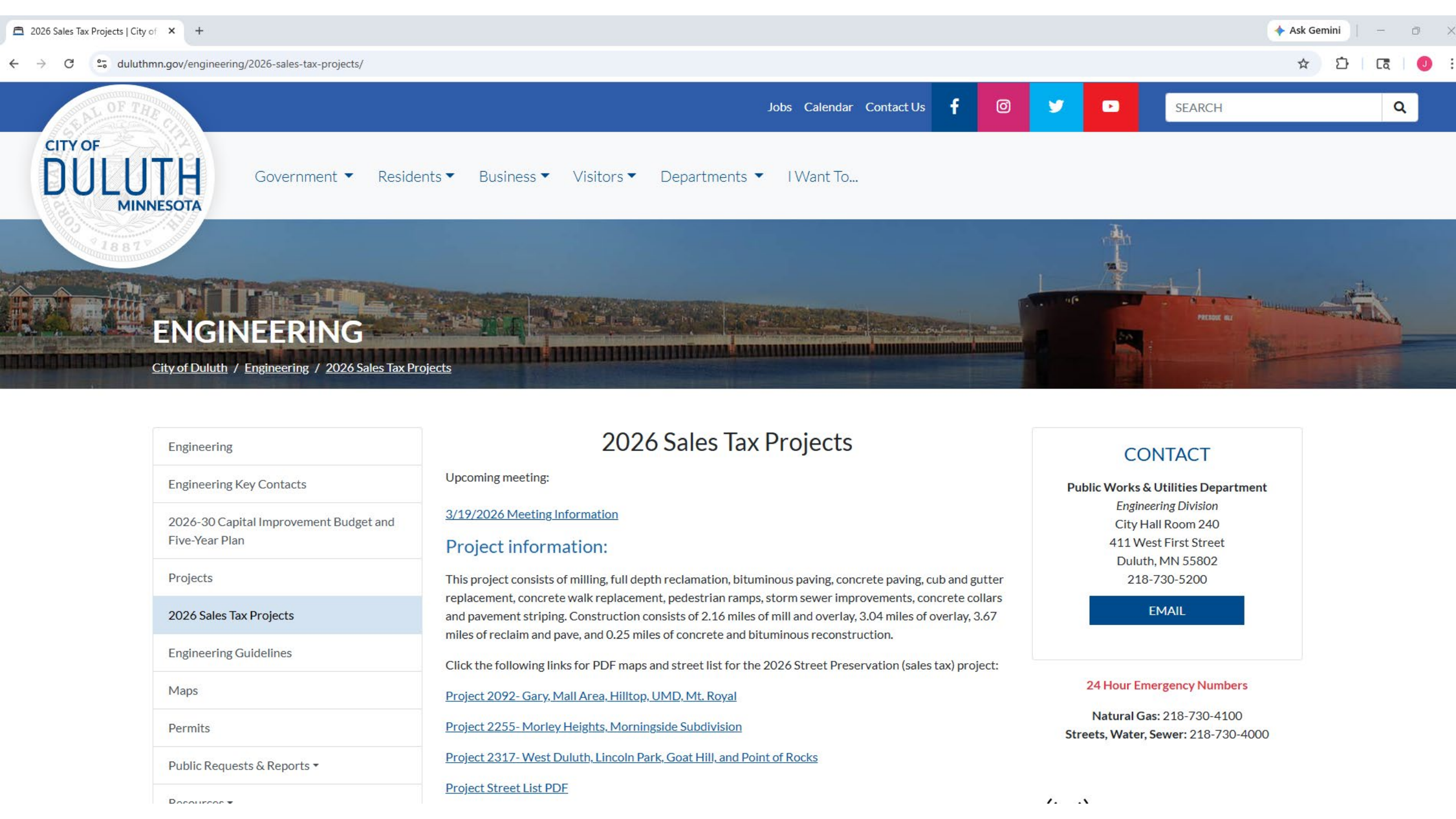

Jobs Calendar Contact Us



SEARCH

Government ▾ Residents ▾ Business ▾ Visitors ▾ Departments ▾ I Want To...

ENGINEERING

City of Duluth / Engineering / 2026 Sales Tax Projects

Engineering
Engineering Key Contacts
2026-30 Capital Improvement Budget and Five-Year Plan
Projects
2026 Sales Tax Projects
Engineering Guidelines
Maps
Permits
Public Requests & Reports ▾
Resources ▾

2026 Sales Tax Projects

Upcoming meeting:

[3/19/2026 Meeting Information](#)

Project information:

This project consists of milling, full depth reclamation, bituminous paving, concrete paving, curb and gutter replacement, concrete walk replacement, pedestrian ramps, storm sewer improvements, concrete collars and pavement striping. Construction consists of 2.16 miles of mill and overlay, 3.04 miles of overlay, 3.67 miles of reclaim and pave, and 0.25 miles of concrete and bituminous reconstruction.

Click the following links for PDF maps and street list for the 2026 Street Preservation (sales tax) project:

[Project 2092- Gary, Mall Area, Hilltop, UMD, Mt. Royal](#)

[Project 2255- Morley Heights, Morningside Subdivision](#)

[Project 2317- West Duluth, Lincoln Park, Goat Hill, and Point of Rocks](#)

[Project Street List PDF](#)

CONTACT

Public Works & Utilities Department
Engineering Division
City Hall Room 240
411 West First Street
Duluth, MN 55802
218-730-5200

[EMAIL](#)

24 Hour Emergency Numbers

Natural Gas: 218-730-4100
Streets, Water, Sewer: 218-730-4000



Questions?

<https://duluthmn.gov/engineering/2026-sales-tax-projects/>

