





Purchasing Division
Finance Department
Room 120
411 West First Street
Duluth, Minnesota 55802

 218-730-5340
 purchasing@duluthmn.gov

Addendum No. 2
Solicitation #25-0431

Scope 1: Coal Burner to Natural Gas and Fuel Oil Burner: Balance of Plant and Fuel Oil System

This addendum serves to notify all bidders of the following changes to the solicitation documents:

1. Please insert the attached document labeled 'Exhibit A' into the Bid Package.
2. Please insert the attached document labeled 'Exhibit B' into the Bid Package.

Please acknowledge receipt of this Addendum by checking the acknowledgement box within the www.bidexpress.com solicitation.

Posted: **June 16, 2025**

NOTES:
 1. ALL WORK ON THIS SHEET TO BE COMPLETED BY BURNER CONTRACTOR. UNLESS NOTED OTHERWISE.

DEMO STEAM TURBINE
 REMOVE STEAM AND CONDENSATE
 PIPING FROM TURBINE. BLIND FLANGE
 AT STEAM AND CONDENSATE
 HEADERS.

REMOVE INSPECTION PORTS,
 RESEAL EACH WITH HIGH
 TEMPERATURE RTV SILICONE,
 AND REINSTALL INSPECTION
 PORTS. (TYP. 7 PORTS PER
 BOILER)

CONDENSATE
 RECEIVER TANK

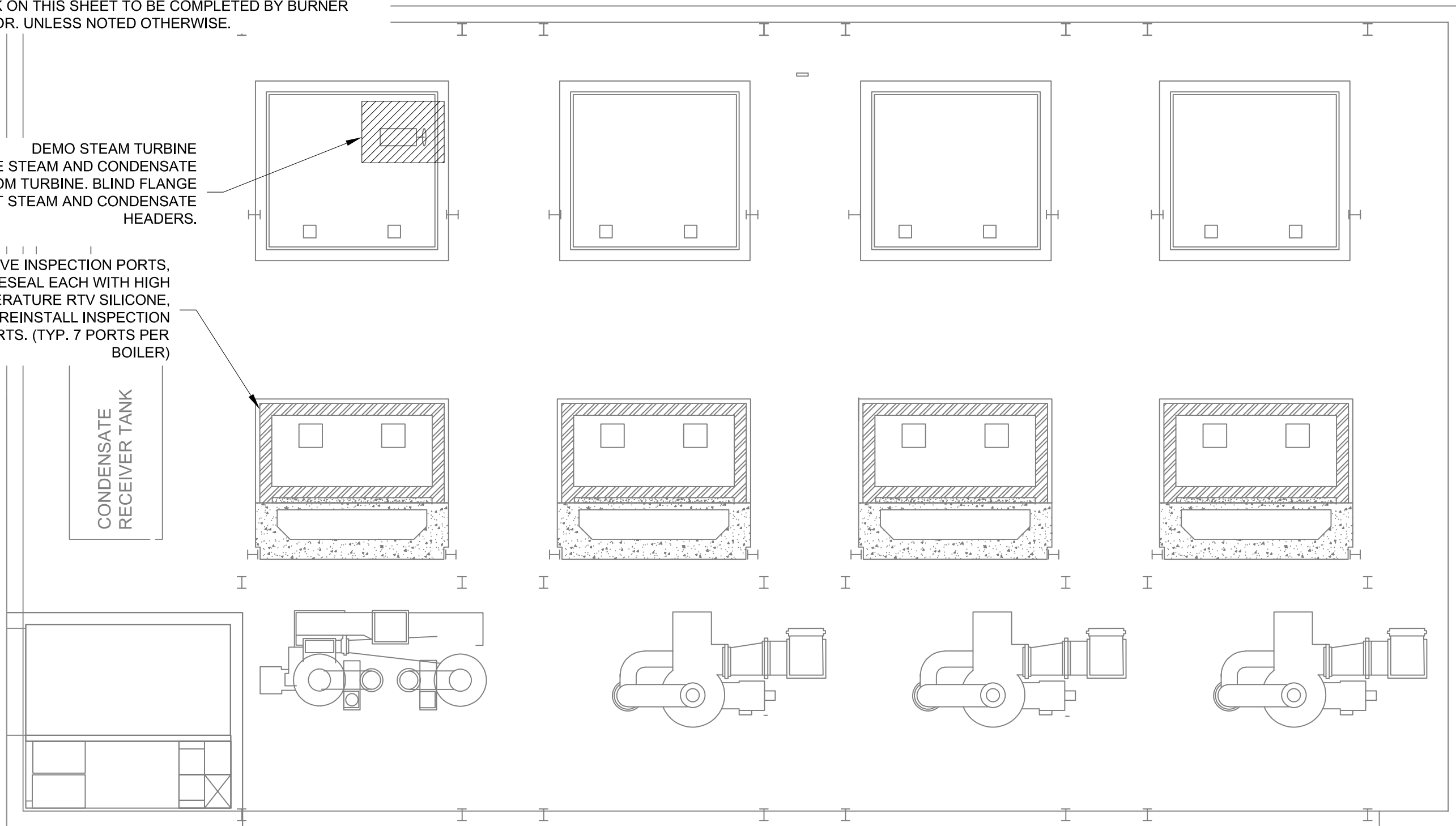

NOT FOR CONSTRUCTION - FOR BID ONLY

I HEREBY CERTIFY THAT THIS PLAN, SPECIFICATION OR REPORT WAS PREPARED BY ME OR UNDER MY DIRECT SUPERVISION AND THAT I AM A DULY REGISTERED PROFESSIONAL ENGINEER UNDER THE LAWS OF MINNESOTA.

RYAN JOHNSON

DATE _____ REG. NO. 49918

REV.	DATE	PREP. BY	CHK'D BY	DESCRIPTION
IFB	4/29/25	TJW	RJJ	ISSUED FOR BID



DES COAL SUNSETTING

GROUND FLOOR
 DEMO

DESIGN BY: RJJ DATE: 4/29/25
 DRAWN BY: TJW DATE: 4/29/25
 HORZ: 1"=10'

Project No. EGE0103

Sheet No. M100

NOTES:
 1. ALL WORK ON THIS SHEET TO BE COMPLETED BY BURNER CONTRACTOR. UNLESS NOTED OTHERWISE.

REMOVE DEMO STEAM TURBINE
 REMOVE STEAM AND CONDENSATE
 PIPING FROM TURBINE. BLIND FLANGE
 AT STEAM AND CONDENSATE
 HEADERS.

REMOVE INSPECTION PORTS, RESEAL EACH
 WITH HIGH TEMPERATURE RTV SILICONE,
 AND REINSTALL INSPECTION PORTS. (TYP. 7
 PORTS PER BOILER)

REMOVE COAL BURNER
 EQUIPMENT. TERMINATE COAL
 CHUTES WITH BLIND FLANGES AT
 COAL BUNKER.
 (TYP. EA. BOILER)

REMOVE FUEL OIL PILOTS AND
 PIPING. CAP FUEL OIL LINE BELOW
 FLOOR
 (TYP. BOILER 1&4)

INSTALL PLATES AND BLIND
 FLANGES ON PULVERIZERS AND
 COAL EQUIPMENT TERMINATED
 BELOW THE FLOOR.
 (TYP. EA. BOILER)

REESTABLISH CONCRETE FLOOR. FILL
 HOLES IN SLAB WHERE COAL
 EQUIPMENT BREACHED THE FLOOR.
 (TYP. EA. BOILER)

NOT FOR CONSTRUCTION - FOR BID ONLY

I HEREBY CERTIFY THAT THIS PLAN, SPECIFICATION OR REPORT WAS PREPARED
 BY ME OR UNDER MY DIRECT SUPERVISION AND THAT I AM A DULY REGISTERED
 PROFESSIONAL ENGINEER UNDER THE LAWS OF MINNESOTA.

RYAN JOHNSON

DATE _____ REG. NO. 49918

IFB	4/29/2025	TJW	RJJ	ISSUED FOR BID
REV.	DATE	PREP. BY	CHK'D BY	DESCRIPTION



EVER-GREEN ENERGY™

DES COAL SUNSETTING

FIRST FLOOR DEMO

DESIGN BY: RJJ DATE: 4/25/25
 DRAWN BY: TJW DATE: 4/25/25

HORZ: 1"=10'

Project No. EGE0103

Sheet No. M101

NOTES:

1. ALL WORK ON THIS SHEET TO BE COMPLETED BY BALANCE OF PLANT CONTRACTOR. UNLESS NOTED OTHERWISE.
2. BOILERS 1 AND 4 WILL RECEIVE NEW NATURAL GAS AND FUEL OIL BURNERS AND FUEL SKIDS. BOILERS 2 AND 3 WILL RECEIVE NEW FUEL OIL BURNERS AND FUEL SKIDS. BURNERS AND FUEL SKIDS TO BE PROVIDED AND INSTALLED BY BURNER CONTRACTOR.
3. COORDINATE FINAL FUEL SKID ORIENTATION AND CONNECTIONS WITH BURNER CONTRACTOR.
4. SUPPORT PIPING FROM BEAMS AND COLUMNS OR FLOOR SUPPORTS.
5. FUEL OIL BURNER SUPPLY BRANCHES SHALL BE FROM UNDERSIDE OF MAIN PIPING (DOWNFEED).
6. PROVIDE 3/4 INCH VENTS AT HIGH POINTS AND 3/4 INCH DRAINS AT LOW POINTS IN FUEL OIL PIPING SYSTEM. PROVIDE 3/4 INCH BALL VALVES WITH CAP. DO NOT CREATE AIR TRAPS IN FUEL OIL SUPPLY PIPING.

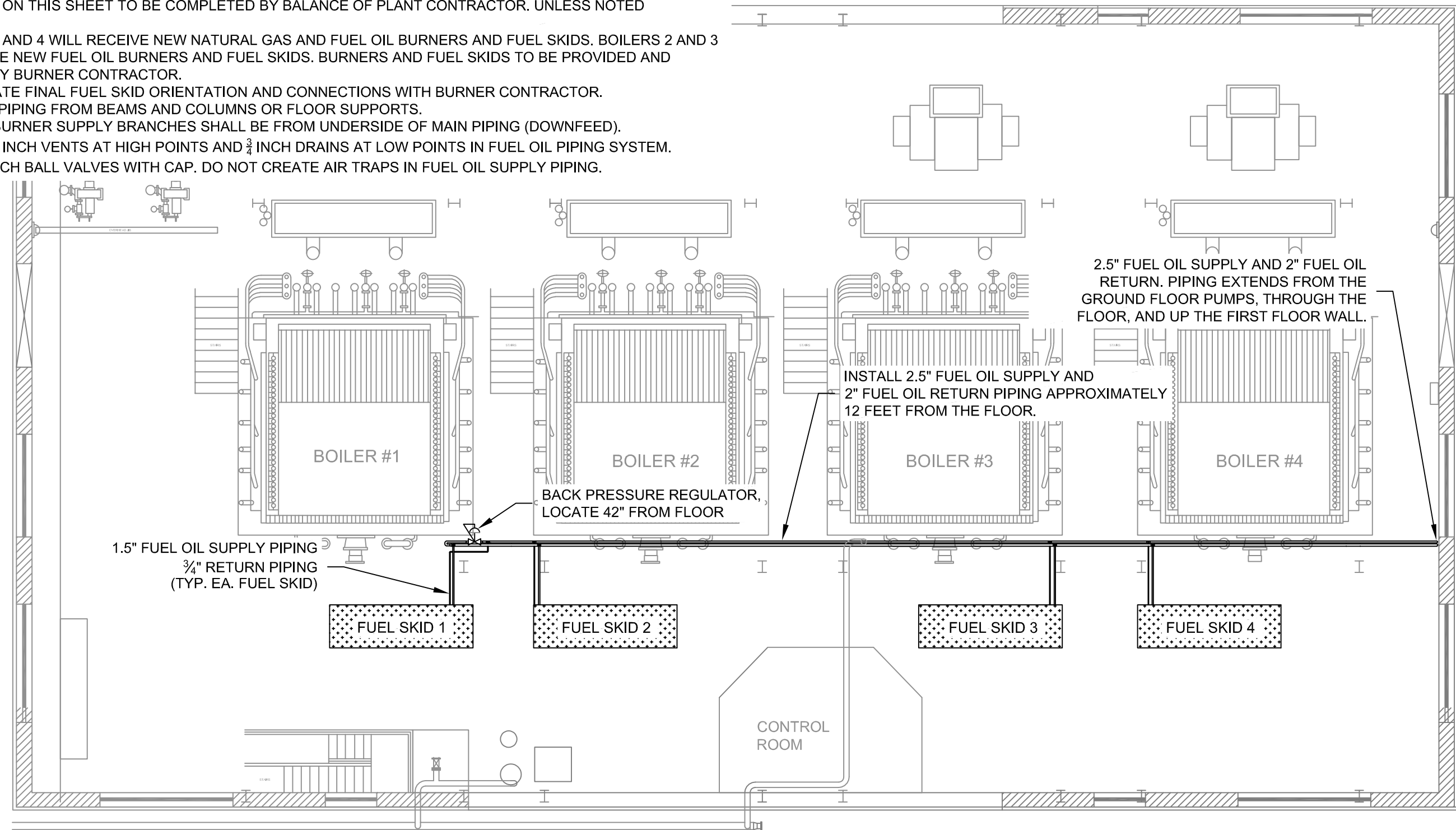

NOT FOR CONSTRUCTION - FOR BID ONLY

I HEREBY CERTIFY THAT THIS PLAN, SPECIFICATION OR REPORT WAS PREPARED BY ME OR UNDER MY DIRECT SUPERVISION AND THAT I AM A DULY REGISTERED PROFESSIONAL ENGINEER UNDER THE LAWS OF MINNESOTA.

RYAN JOHNSON

DATE _____ REG. NO. 49918

IFB	4/29/25	TJW	RJJ	ISSUED FOR BID
REV.	DATE	PREP. BY	CHK'D BY	DESCRIPTION



EVER-GREEN ENERGY™

DES COAL SUNSETTING

FIRST FLOOR FUEL OIL

DESIGN BY: RJJ DATE: 4/25/25
DRAWN BY: TJW DATE: 4/25/25

HORZ: 1"=10'

Project No. EGE0103

Sheet No. M201

- NOTES:
1. ALL WORK ON THIS SHEET TO BE COMPLETED BY BALANCE OF PLANT CONTRACTOR. UNLESS NOTED OTHERWISE.
 2. BOILERS 1 AND 4 WILL RECEIVE NEW NATURAL GAS AND FUEL OIL BURNERS AND FUEL SKIDS. BOILERS 2 AND 3 WILL RECEIVE NEW FUEL OIL BURNERS AND FUEL SKIDS. BURNERS AND FUEL SKIDS TO BE PROVIDED AND INSTALLED BY BURNER CONTRACTOR.
 3. COORDINATE FINAL FUEL SKID ORIENTATION AND CONNECTIONS WITH BURNER CONTRACTOR.
 4. SLOPE CONDENSATE PIPING AT A MINIMUM UNIFORM GRADE OF 0.4 PERCENT DOWNWARD IN THE DIRECTION OF CONDENSATE FLOW.
 5. PROVIDE DRIP TRAP ASSEMBLIES AT LOW POINTS AND BEFORE CONTROL VALVES.
 6. SUPPORT PIPING FROM BEAMS AND COLUMNS OR FLOOR SUPPORTS.

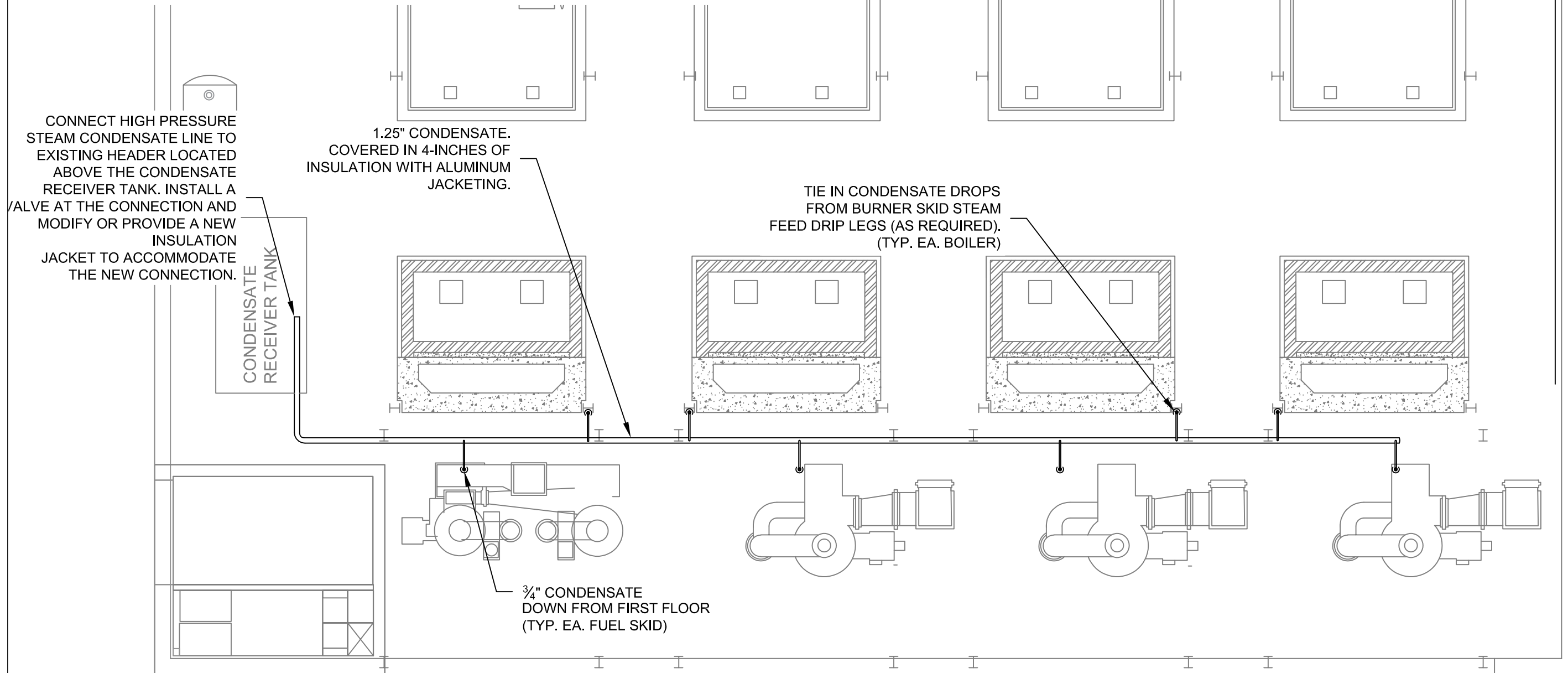

NOT FOR CONSTRUCTION - FOR BID ONLY

I HEREBY CERTIFY THAT THIS PLAN, SPECIFICATION OR REPORT WAS PREPARED BY ME OR UNDER MY DIRECT SUPERVISION AND THAT I AM A DULY REGISTERED PROFESSIONAL ENGINEER UNDER THE LAWS OF MINNESOTA.

RYAN JOHNSON

DATE _____ REG. NO. 49918

IFB	4/30/2025	TJW	RJJ	ISSUED FOR BID
REV.	DATE	PREP. BY	CHK'D BY	DESCRIPTION



DES COAL SUNSETTING

DESIGN BY: RJJ DATE: 4/25/25
DRAWN BY: TJW DATE: 4/25/25

HORZ: 1"=10'

GROUND FLOOR
STEAM CONDENSATE

Project No. EGE0103

Sheet No. M202

NOTES:

1. ALL WORK ON THIS SHEET TO BE COMPLETED BY BALANCE OF PLANT CONTRACTOR. UNLESS NOTED OTHERWISE.
2. BOILERS 1 AND 4 WILL RECEIVE NEW NATURAL GAS AND FUEL OIL BURNERS AND FUEL SKIDS. BOILERS 2 AND 3 WILL RECEIVE NEW FUEL OIL BURNERS AND FUEL SKIDS. BURNERS AND FUEL SKIDS TO BE PROVIDED AND INSTALLED BY BURNER CONTRACTOR.
3. COORDINATE FINAL FUEL SKID ORIENTATION AND CONNECTIONS WITH BURNER CONTRACTOR.
4. SLOPE CONDENSATE PIPING AT A MINIMUM UNIFORM GRADE OF 0.4 PERCENT DOWNWARD IN THE DIRECTION OF CONDENSATE FLOW.
5. PROVIDE DRIP TRAP ASSEMBLIES AT LOW POINTS AND BEFORE CONTROL VALVES.
6. SUPPORT PIPING FROM BEAMS AND COLUMNS OR FLOOR SUPPORTS.

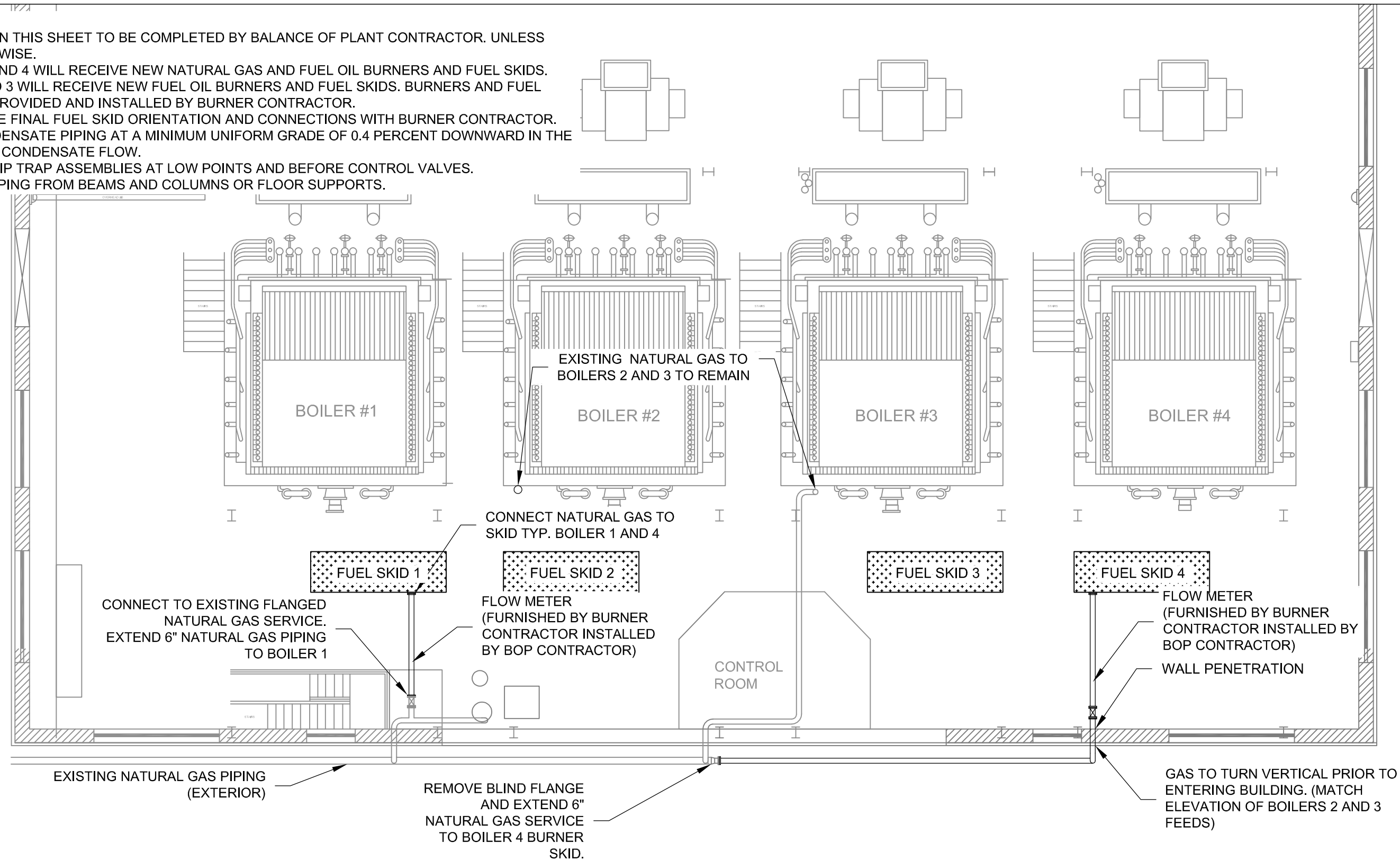

NOT FOR CONSTRUCTION - FOR BID ONLY

I HEREBY CERTIFY THAT THIS PLAN, SPECIFICATION OR REPORT WAS PREPARED BY ME OR UNDER MY DIRECT SUPERVISION AND THAT I AM A DULY REGISTERED PROFESSIONAL ENGINEER UNDER THE LAWS OF MINNESOTA.

RYAN JOHNSON

DATE _____ REG. NO. 49918

IFB	4/29/2025	TJW	RJJ	ISSUED FOR BID
REV.	DATE	PREP. BY	CHK'D BY	DESCRIPTION



EVER-GREEN ENERGY™

DES COAL SUNSETTING

FIRST FLOOR
NATURAL GAS

DESIGN BY: RJJ DATE: 4/29/25
DRAWN BY: TJW DATE: 4/29/25

HORZ: 1"=10'

Project No. EGE0103

Sheet No. M204

NOTES:

1. ALL WORK ON THIS SHEET TO BE COMPLETED BY BALANCE OF PLANT CONTRACTOR. UNLESS NOTED OTHERWISE.
2. BOILERS 1 AND 4 WILL RECEIVE NEW NATURAL GAS AND FUEL OIL BURNERS AND FUEL SKIDS. BOILERS 2 AND 3 WILL RECEIVE NEW FUEL OIL BURNERS AND FUEL SKIDS. BURNERS AND FUEL SKIDS TO BE PROVIDED AND INSTALLED BY BURNER CONTRACTOR.
3. COORDINATE FINAL FUEL SKID ORIENTATION AND CONNECTIONS WITH BURNER CONTRACTOR.
4. SUPPORT PIPING FROM BEAMS AND COLUMNS OR FLOOR SUPPORTS.

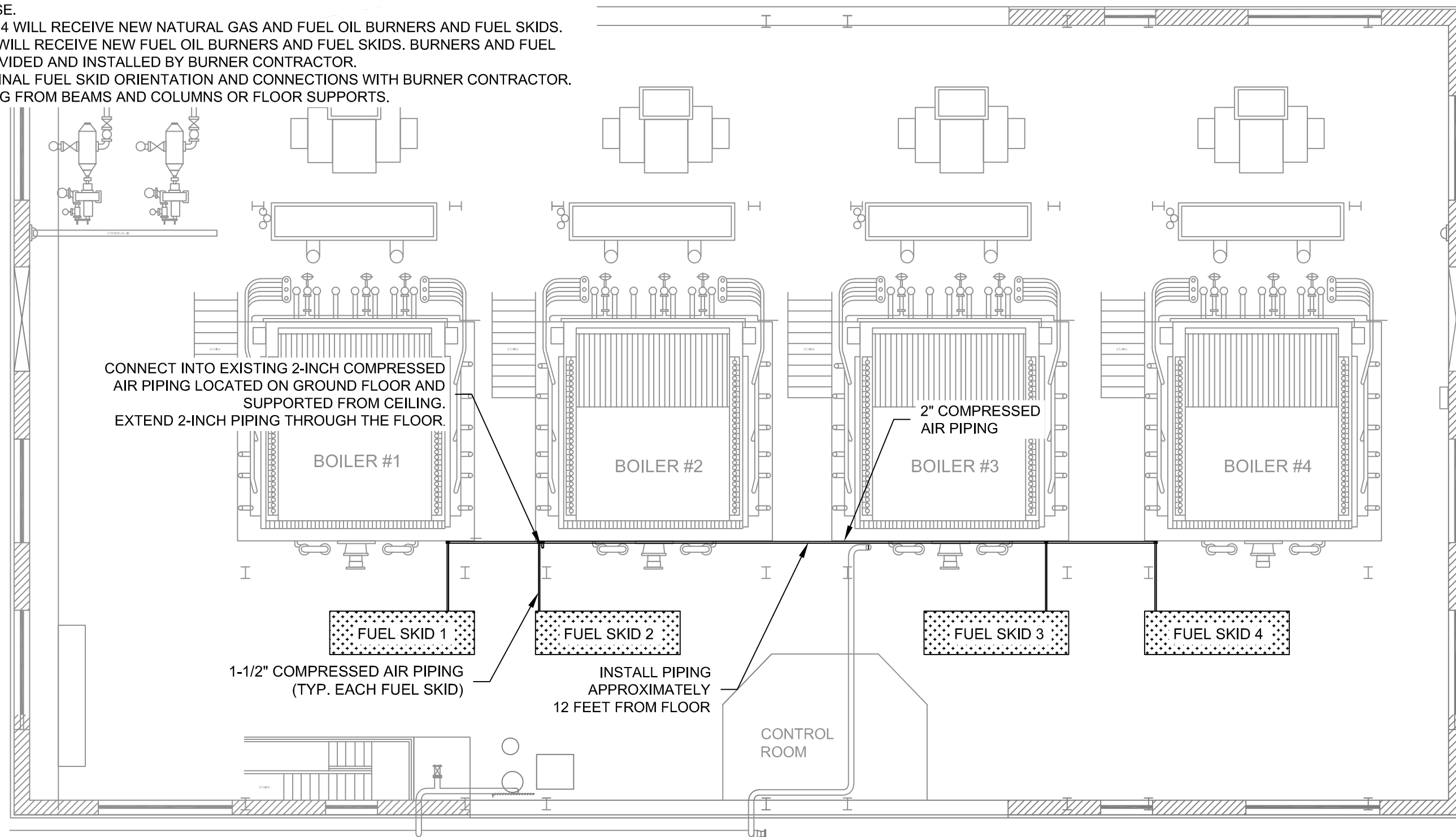

NOT FOR CONSTRUCTION - FOR BID ONLY

I HEREBY CERTIFY THAT THIS PLAN, SPECIFICATION OR REPORT WAS PREPARED BY ME OR UNDER MY DIRECT SUPERVISION AND THAT I AM A DULY REGISTERED PROFESSIONAL ENGINEER UNDER THE LAWS OF MINNESOTA.

RYAN JOHNSON

DATE _____ REG. NO. 49918

REV.	DATE	PREP. BY	CHK'D BY	DESCRIPTION
IFB	4/29/2025	TJW	RJJ	ISSUED FOR BID



EVER-GREEN ENERGY™

DES COAL SUNSETTING

FIRST FLOOR
ATOMIZING AIR

DESIGN BY: RJJ DATE: 4/29/2025
DRAWN BY: TJW DATE: 4/29/2025

HORZ: 1"=10'

Project No. EGE0103

Sheet No. M205

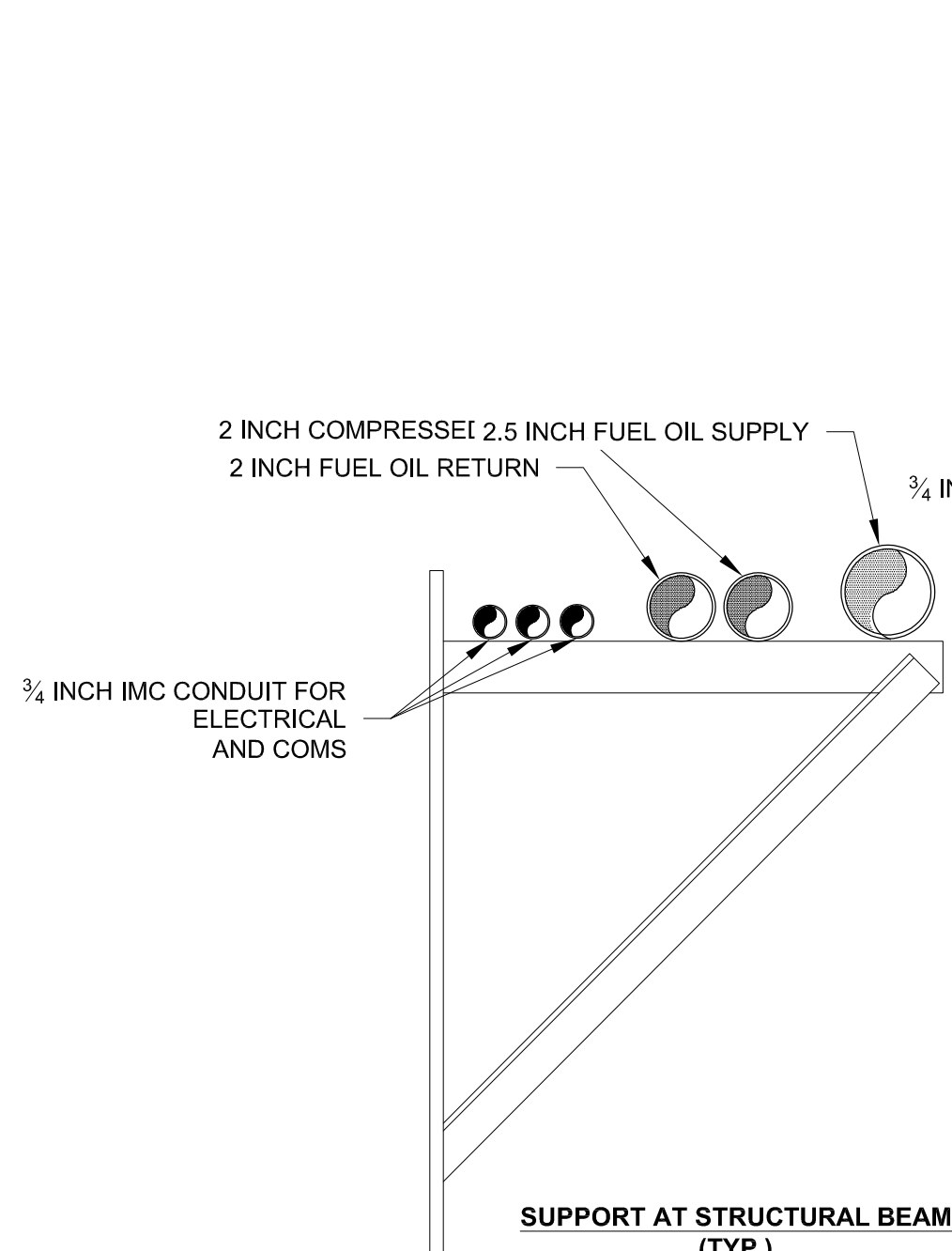

- NOTES:
1. ANVIL FIG. 195 OR WELDED STEEL BRACKET (OR APPROVED EQUAL)
 2. WELD ATTACHMENT INTO FACE OF BEAM OR WEB.
 3. ALTERNATIVE ATTACHMENT METHODS UPON APPROVAL.
 4. 10 FOOT MAXIMUM SPACING BETWEEN HANGERS.

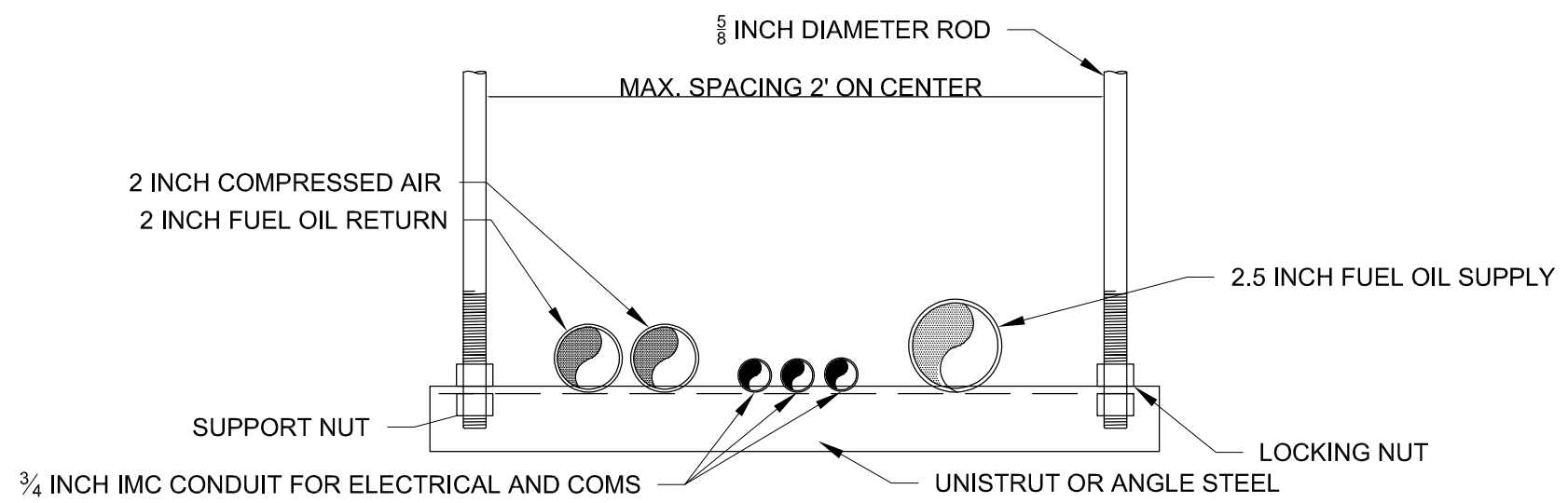

TRAPEZE HANGER DETAIL

- NOTES:
1. 10 FOOT MAXIMUM SPACING BETWEEN HANGERS PIPING U-BOLTED OR STRAPPED TO TRAPEZE

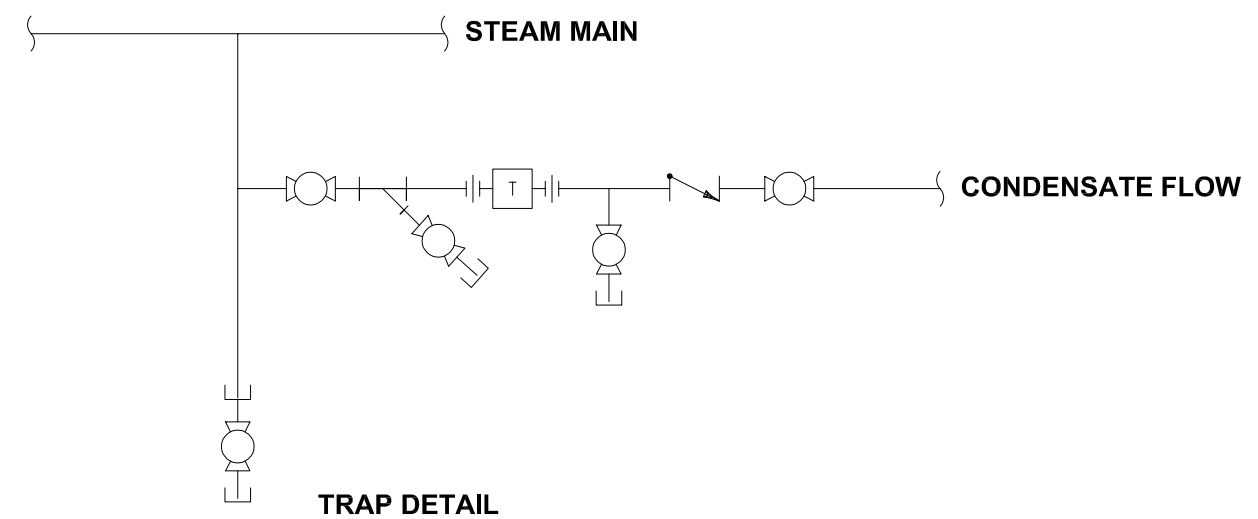

- NOTES:
1. FOR STEAM MAINS UP TO 4 INCHES, THE DRIP LEG SHALL BE THE SAME SIZE AS THE STEAM MAIN. FOR STEAM MAINS LARGER THAN 4 INCHES, THE DRIP LEG CAN BE HALF THE DIAMETER OF THE STEAM MAIN, BUT NEVER LESS THAN 4 INCHES.
 2. THE LENGTH OF DRIP LEG SHALL BE A MINIMUM OF 28 INCHES.
 3. THE TRAP LINE SHALL BE MINIMUM 6 INCHES FROM BOTTOM OF DRIP LEG.
 4. INSTALL A DRAIN VALVE AT THE BASE OF THE DRIP LEG.

NOT FOR CONSTRUCTION - FOR BID ONLY

I HEREBY CERTIFY THAT THIS PLAN, SPECIFICATION OR REPORT WAS PREPARED BY ME OR UNDER MY DIRECT SUPERVISION AND THAT I AM A DULY REGISTERED PROFESSIONAL ENGINEER UNDER THE LAWS OF MINNESOTA.

RYAN JOHNSON

DATE _____ REG. NO. 49918

REV.	DATE	PREP. BY	CHK'D BY	DESCRIPTION



EVER-GREEN ENERGY™

DES COAL SUNSETTING

MECHANICAL DETAILS

DESIGN BY: RLJ
DRAWN BY: TJW

DATE: 4/29/25
DATE: 4/29/25

HORZ: N.T.S.

Project No. EGE0103

Sheet No. M400

NOTES:

1. ALL WORK ON THIS SHEET TO BE COMPLETED BY BALANCE OF PLANT CONTRACTOR. UNLESS NOTED OTHERWISE.
2. PROVIDE ALL FEATURES AND COMPONENTS IN COMPLIANCE WITH APPLICABLE CODES AND REGULATIONS.
3. INSTALL ALL FUEL OIL TANK AND SYSTEM COMPONENTS, CONTROLS, ACCESSORIES AS PER MANUFACTURER'S RECOMMENDATION AND APPLICABLE CODES REGULATIONS.
4. THE CONTRACTOR SHALL COORDINATE WITH TANK MANUFACTURER FOR ALL TANK FITTINGS, SIZING, AND PORT LOCATIONS.
5. PROVIDE A VEEDER-ROOT TLS-450 PLUS FUEL OIL MANAGEMENT SYSTEM, OR APPROVED SUBSTITUTION. AT A MINIMUM, THE SYSTEM SHALL PROVIDE THE FOLLOWING FUNCTIONALITIES: TANK INVENTORY LEVEL INFORMATION, TANK LEAK DETECTION, PIPING LEAK DETECTION, SENSOR CONFIGURATION, COMPLIANCE LEAK TESTING, LOW LEVEL ALARM, HIGH LEVEL ALARM, AND TANK LEVEL ALARM.
6. COORDINATE BURNER SKID FUEL OIL CONNECTION POINTS WITH BURNER INSTALLATION CONTRACTOR.
7. PROVIDE A 3/4" FULL PORT BALL VALVE WITH THREADED NIPPLE AND CAP AT HIGH AND LOW POINTS FOR VENTING AND DRAINING THE PIPING SYSTEM. DO NOT CREATE AIR TRAPS IN FUEL OIL SUPPLY PIPING SYSTEM.
8. PROVIDE VACUUM BREAKER(S) WITH VENT PROTECTORS AT HIGHEST POINT(S) OF RISER LINES.

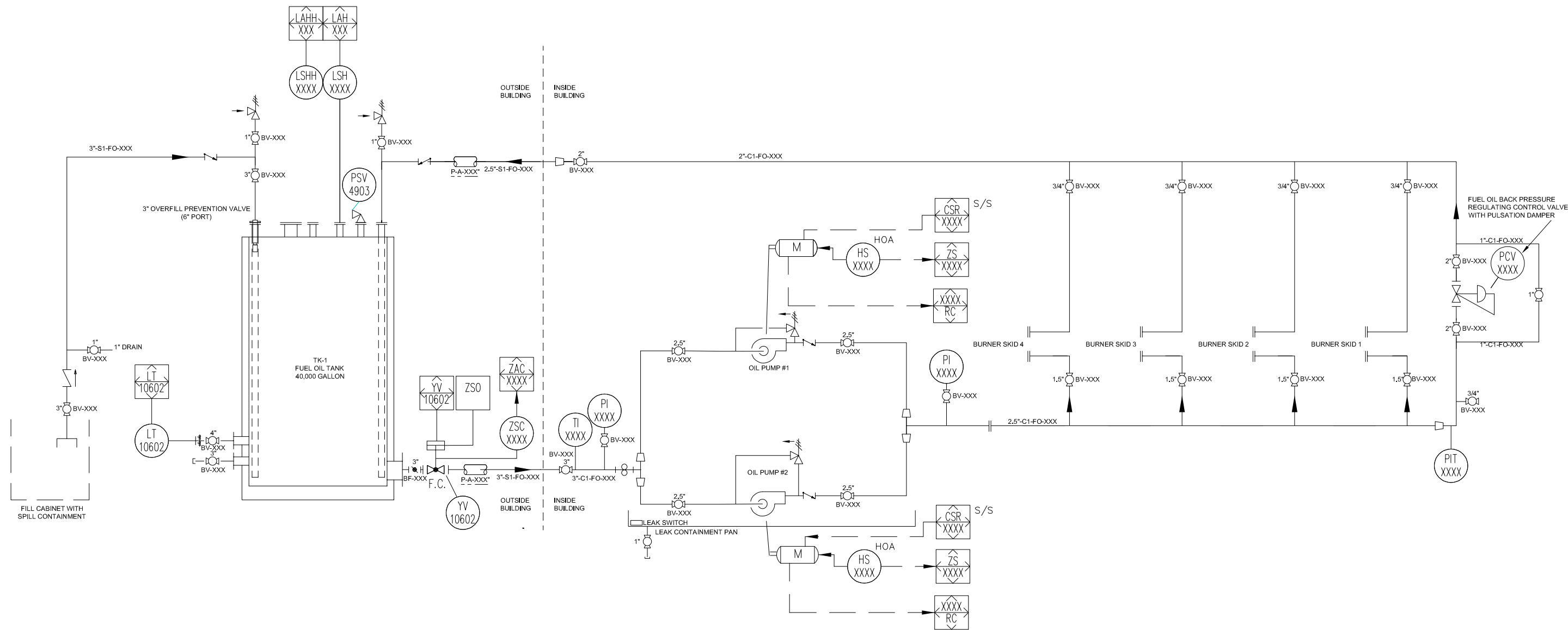

NOT FOR CONSTRUCTION - FOR BID ONLY

I HEREBY CERTIFY THAT THIS PLAN, SPECIFICATION OR REPORT WAS PREPARED BY ME OR UNDER MY DIRECT SUPERVISION AND THAT I AM A DULY REGISTERED PROFESSIONAL ENGINEER UNDER THE LAWS OF MINNESOTA.

RYAN JOHNSON

DATE _____ REG. NO. 49918

IFB	4/30/2025	TJW	RJJ	ISSUED FOR BID
REV.	DATE	PREP. BY	CHK'D BY	DESCRIPTION



DES COAL SUNSETTING

FUEL OIL TANK P&ID

DESIGN BY: RJJ DATE: 02/06/25
DRAWN BY: TJW DATE: 02/06/25

HORZ: N.T.S.

Project No. EGE0103

Sheet No. M501

TAGS: BLR 1- 1XXXX
 BLR 2- 2XXXX
 BLR 3- 3XXXX
 BLR 4- 4XXXX

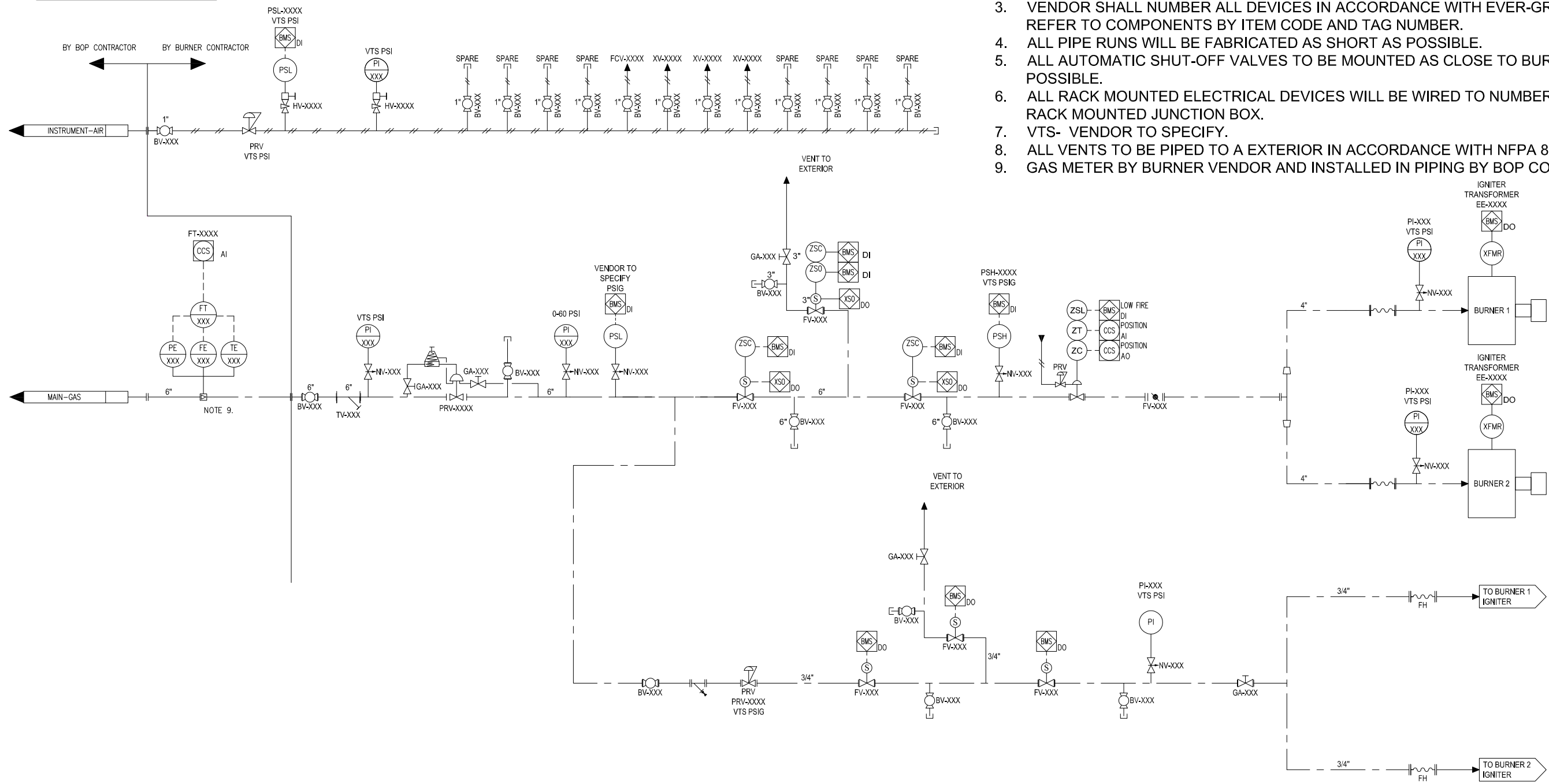

GENERAL NOTES

1. ALL WORK ON THIS SHEET TO BE COMPLETED BY BURNER CONTRACTOR. UNLESS NOTED OTHERWISE.
2. THIS DRAWING IS FURNISHED FOR REFERENCE ONLY TO PROVIDE TYPICAL FUEL GAS TRAIN AND CONNECTIONS TO BURNER MANAGEMENT SYSTEM AND COMBUSTION CONTROL SYSTEM. VENDOR TO PROVIDE COMPLETE P&ID FOR COMPLETED INSTALLATION FOR BOILER 1 AND 4 AND DESIGN TO BE IN ACCORDANCE WITH NFPA 85. IT IS VENDOR'S RESPONSIBILITY TO SIZE ALL VALVES, PIPE, AND PRESSURE RANGES OF INSTRUMENTS.
3. VENDOR SHALL NUMBER ALL DEVICES IN ACCORDANCE WITH EVER-GREEN STANDARD AND REFER TO COMPONENTS BY ITEM CODE AND TAG NUMBER.
4. ALL PIPE RUNS WILL BE FABRICATED AS SHORT AS POSSIBLE.
5. ALL AUTOMATIC SHUT-OFF VALVES TO BE MOUNTED AS CLOSE TO BURNER INLETS AS POSSIBLE.
6. ALL RACK MOUNTED ELECTRICAL DEVICES WILL BE WIRED TO NUMBERED TERMINALS IN A RACK MOUNTED JUNCTION BOX.
7. VTS- VENDOR TO SPECIFY.
8. ALL VENTS TO BE PIPED TO A EXTERIOR IN ACCORDANCE WITH NFPA 85 GUIDELINES.
9. GAS METER BY BURNER VENDOR AND INSTALLED IN PIPING BY BOP CONTRACTOR.

NOT FOR CONSTRUCTION - FOR BID ONLY

I HEREBY CERTIFY THAT THIS PLAN, SPECIFICATION OR REPORT WAS PREPARED BY ME OR UNDER MY DIRECT SUPERVISION AND THAT I AM A DULY REGISTERED PROFESSIONAL ENGINEER UNDER THE LAWS OF MINNESOTA.
 _____ RYAN JOHNSON
 DATE _____ REG. NO. 49918

IFB 4/30/2025	TJW	RJJ	ISSUED FOR BID
REV.	DATE	PREP. BY	CHK'D BY
			DESCRIPTION



DESIGN BY: PB
 DRAWN BY: TJW
 DATE: 02/06/25
 DATE: 02/06/25
 HORZ: N.T.S.

DES COAL SUNSETTING
 FUEL GAS BURNER P&ID
 Project No. EGE0103
 Sheet No. M502

TAGS: BLR 1- 100XXX
 BLR 2- 200XXX
 BLR 3- 300XXX
 BLR 4- 400XXX

GENERAL NOTES

1. ALL WORK ON THIS SHEET TO BE COMPLETED BY BURNER CONTRACTOR. UNLESS NOTED OTHERWISE.
2. THIS DRAWING IS FURNISHED FOR REFERENCE ONLY TO PROVIDE TYPICAL FUEL GAS TRAIN AND CONNECTIONS TO BURNER MANAGEMENT SYSTEM AND COMBUSTION CONTROL SYSTEM. VENDOR TO PROVIDE COMPLETE P&ID FOR COMPLETED INSTALLATION FOR BOILER 1 AND 4 AND DESIGN TO BE IN ACCORDANCE WITH NFPA 85. IT IS VENDOR'S RESPONSIBILITY TO SIZE ALL VALVES, PIPE, AND PRESSURE RANGES OF INSTRUMENTS.
3. VENDOR SHALL NUMBER ALL DEVICES IN ACCORDANCE WITH EVER-GREEN STANDARD AND REFER TO COMPONENTS BY ITEM CODE AND TAG NUMBER.
4. ALL PIPE RUNS WILL BE FABRICATED AS SHORT AS POSSIBLE.
5. ALL AUTOMATIC SHUT-OFF VALVES TO BE MOUNTED AS CLOSE TO BURNER INLETS AS POSSIBLE.
6. ALL RACK MOUNTED ELECTRICAL DEVICES WILL BE WIRED TO NUMBERED TERMINALS IN A RACK MOUNTED JUNCTION BOX.
7. VTS- VENDOR TO SPECIFY.
8. ALL VENTS TO BE PIPED TO A EXTERIOR IN ACCORDANCE WITH NFPA 85 GUIDELINES.

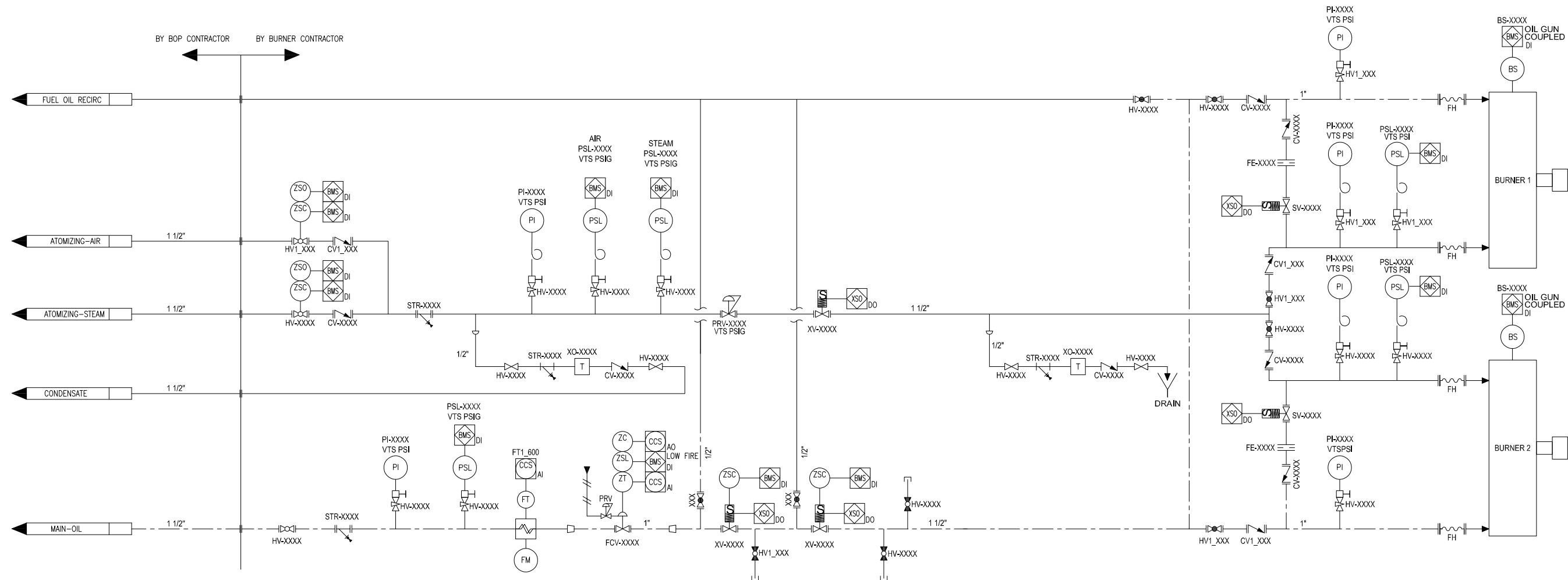

NOT FOR CONSTRUCTION - FOR BID ONLY

I HEREBY CERTIFY THAT THIS PLAN, SPECIFICATION OR REPORT WAS PREPARED BY ME OR UNDER MY DIRECT SUPERVISION AND THAT I AM A DULY REGISTERED PROFESSIONAL ENGINEER UNDER THE LAWS OF MINNESOTA.

RYAN JOHNSON

DATE _____ REG. NO. 49918

IFB	4/29/2025	TJW	RJJ	ISSUED FOR BID
REV.	DATE	PREP. BY	CHK'D BY	DESCRIPTION



DES COAL SUNSETTING

FUEL OIL BURNER P&ID

DESIGN BY: PB
 DRAWN BY: TJW

DATE: 4/29/25
 DATE: 4/29/25

HORZ: N.T.S.

Project No. EGE0103

Sheet No. M503

NOTES:
 EXISTING CONDITIONS FOR BOILER 2 AND 3 FOR REFERENCE ONLY. BOILER 1 AND 4 SIMILAR EXCEPT WITHOUT NATURAL GAS EQUIPMENT. TAGS SHOWN ARE REPRESENTATIVE OF BOILER 3 AND BOILER 2 IS SIMILAR. BURNER CONTRACTOR TO PROVIDE NEW P&ID SIMILAR TO THIS FOR BOILER 1, 2, 3, AND 4 SHOWING ALL EQUIPMENT AND CONTROL ELEMENTS. ALL COAL AND ASH EQUIPMENT TO BE ELIMINATED AS PART OF THE PROJECT.

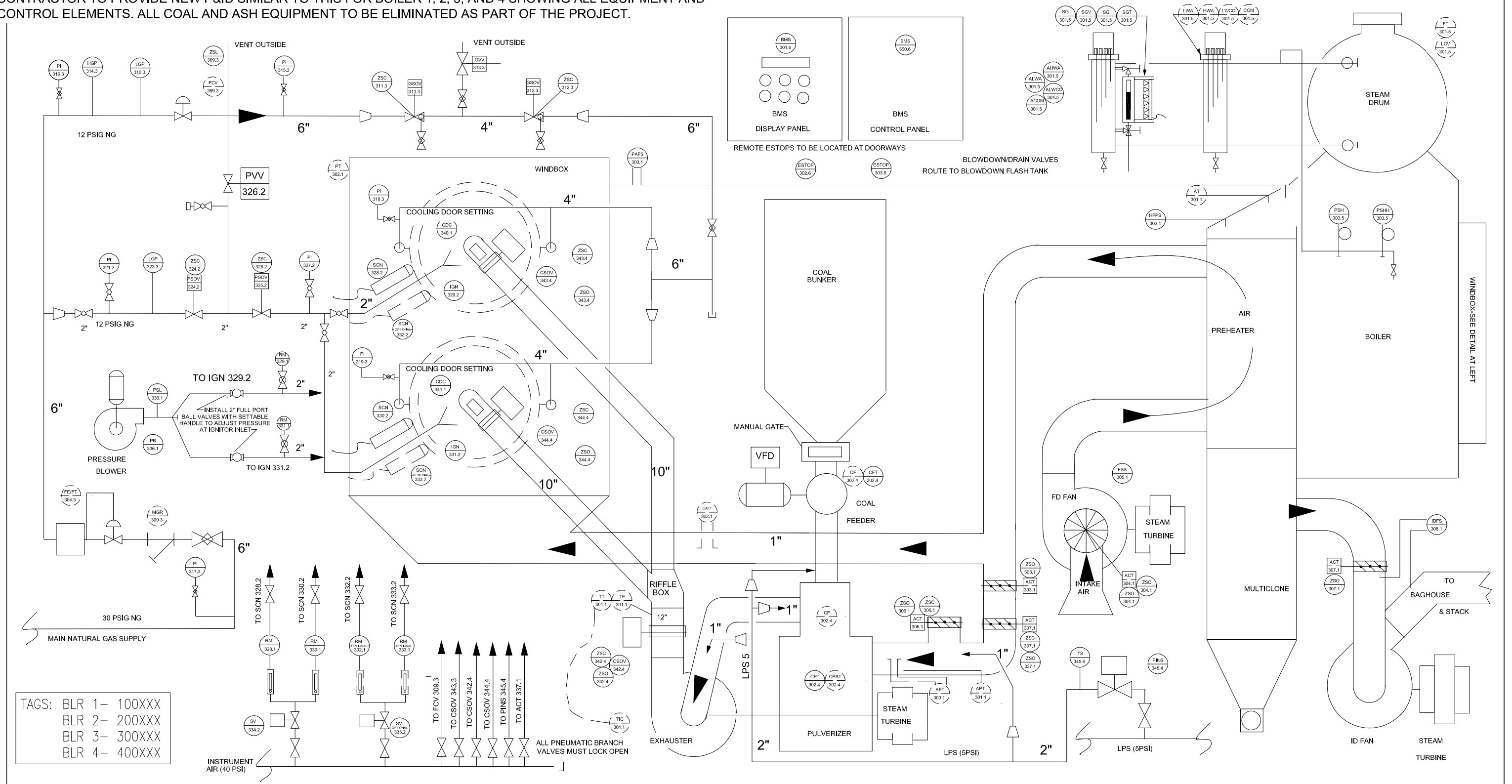

NOT FOR CONSTRUCTION - FOR BID ONLY

I HEREBY CERTIFY THAT THIS PLAN, SPECIFICATION OR REPORT WAS PREPARED BY ME OR UNDER MY DIRECT SUPERVISION AND THAT I AM A DULY REGISTERED PROFESSIONAL ENGINEER UNDER THE LAWS OF MINNESOTA.

RYAN JOHNSON
 DATE _____ REG. NO. 49918

REV.	DATE	PREP. BY	CHK'D BY	DESCRIPTION
IFB	4/29/2025	TJW	RJJ	ISSUED FOR BID



DES COAL SUNSETTING
 DESIGN BY: PB
 DRAWN BY: TJW
 DATE: 4/29/25
 DATE: 4/29/25
 HORZ: N.T.S.

EXISTING BOILER 2 & 3 P&ID
 Project No. EGE0103
 Sheet No. M504

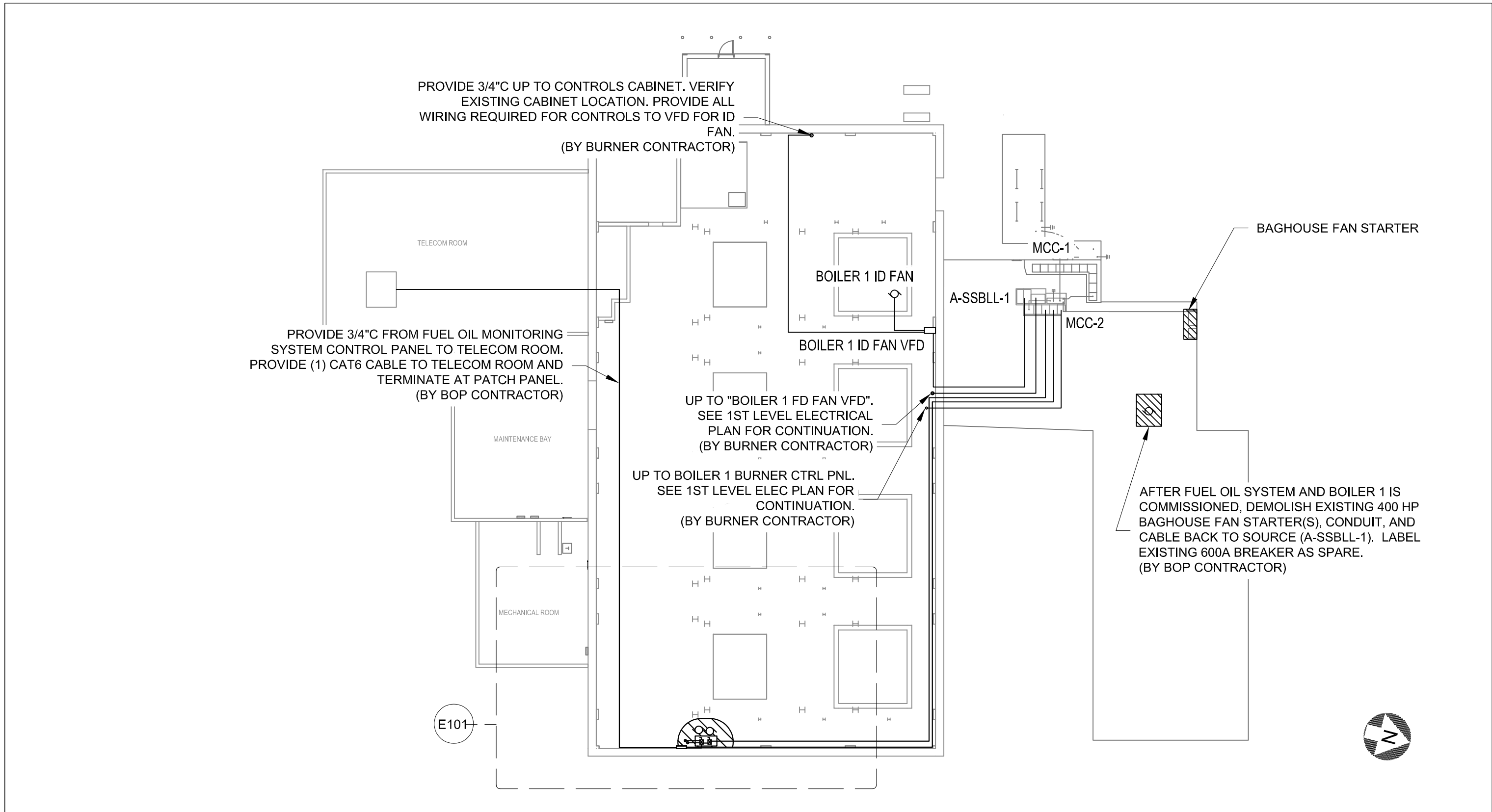

NOT FOR CONSTRUCTION - FOR BID ONLY

I HEREBY CERTIFY THAT THIS PLAN, SPECIFICATION OR REPORT WAS PREPARED BY ME OR UNDER MY DIRECT SUPERVISION AND THAT I AM A DULY REGISTERED PROFESSIONAL ENGINEER UNDER THE LAWS OF MINNESOTA.

NICHOLAS OELKE

DATE _____ REG. NO. 47135

IFB	4/29/25	TJW	RJJ	ISSUED FOR BID
REV.	DATE	PREP. BY	CHK'D BY	DESCRIPTION



DES COAL SUNSETTING

DESIGN BY: RJJ DATE: 4/25/25
DRAWN BY: TJW DATE: 4/25/25
HORZ: 1"=20'

OVERALL GROUND FLOOR ELECTRIC AND COMMUNICATIONS

Project No. EGE0103

Sheet No. E100

NOTES:
 1. ALL WORK ON THIS SHEET TO BE COMPLETED BY BALANCE OF PLANT CONTRACTOR. UNLESS NOTED OTHERWISE.

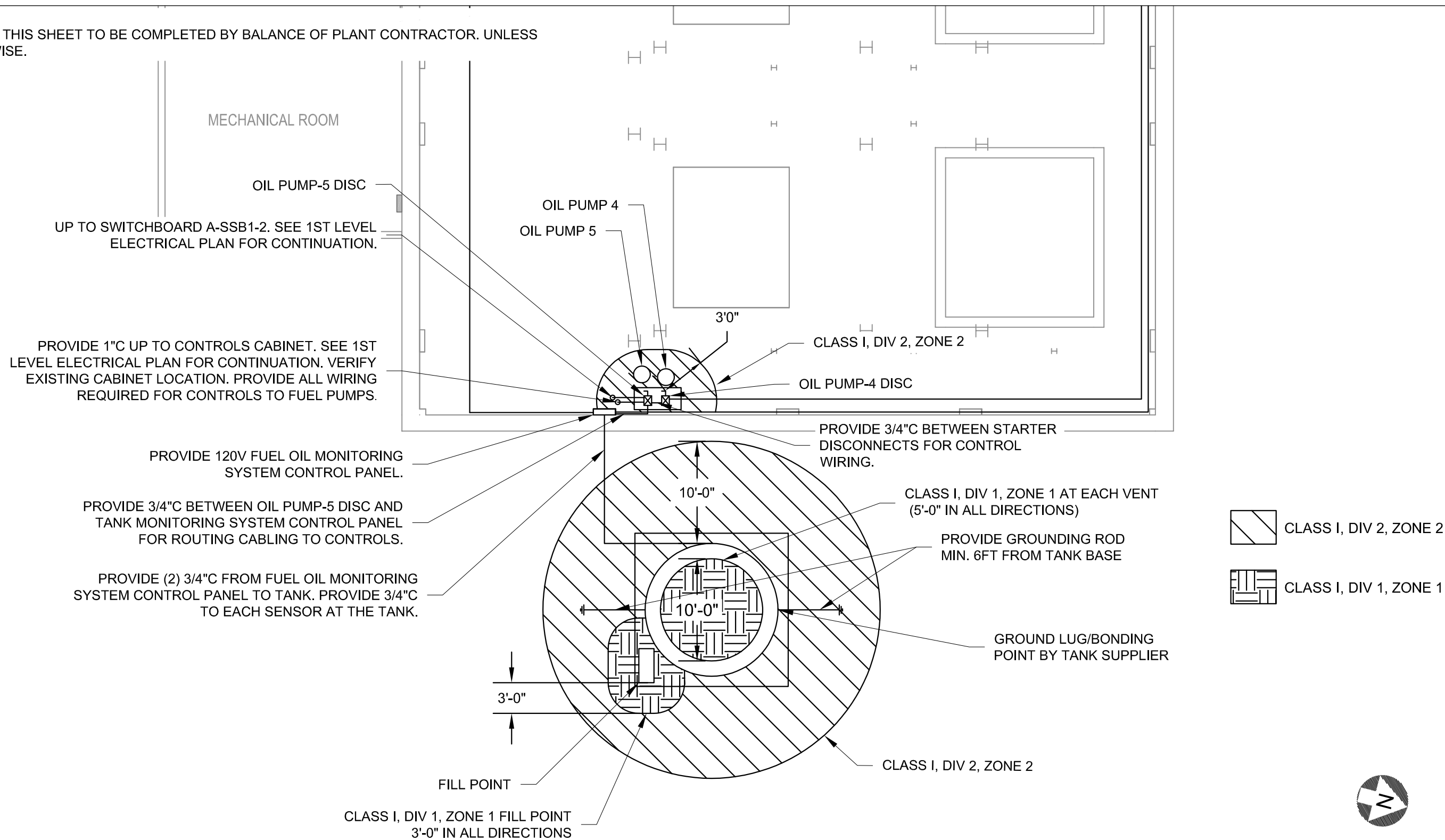

NOT FOR CONSTRUCTION - FOR BID ONLY

I HEREBY CERTIFY THAT THIS PLAN, SPECIFICATION OR REPORT WAS PREPARED BY ME OR UNDER MY DIRECT SUPERVISION AND THAT I AM A DULY REGISTERED PROFESSIONAL ENGINEER UNDER THE LAWS OF MINNESOTA.

NICHOLAS OELKE

DATE _____ REG. NO. 47135

REV.	DATE	PREP. BY	CHK'D BY	DESCRIPTION
IFB	4/29/2025	TJW	RJJ	ISSUED FOR BID



EVER-GREEN ENERGY™

DES COAL SUNSETTING

DESIGN BY: RJJ DATE: 4/29/25
 DRAWN BY: TJW DATE: 4/29/25

HORZ: 1"=10'

GROUND FLOOR TANK
 ELECTRIC AND COMMUNICATIONS

Project No. EGE0103

Sheet No. E101

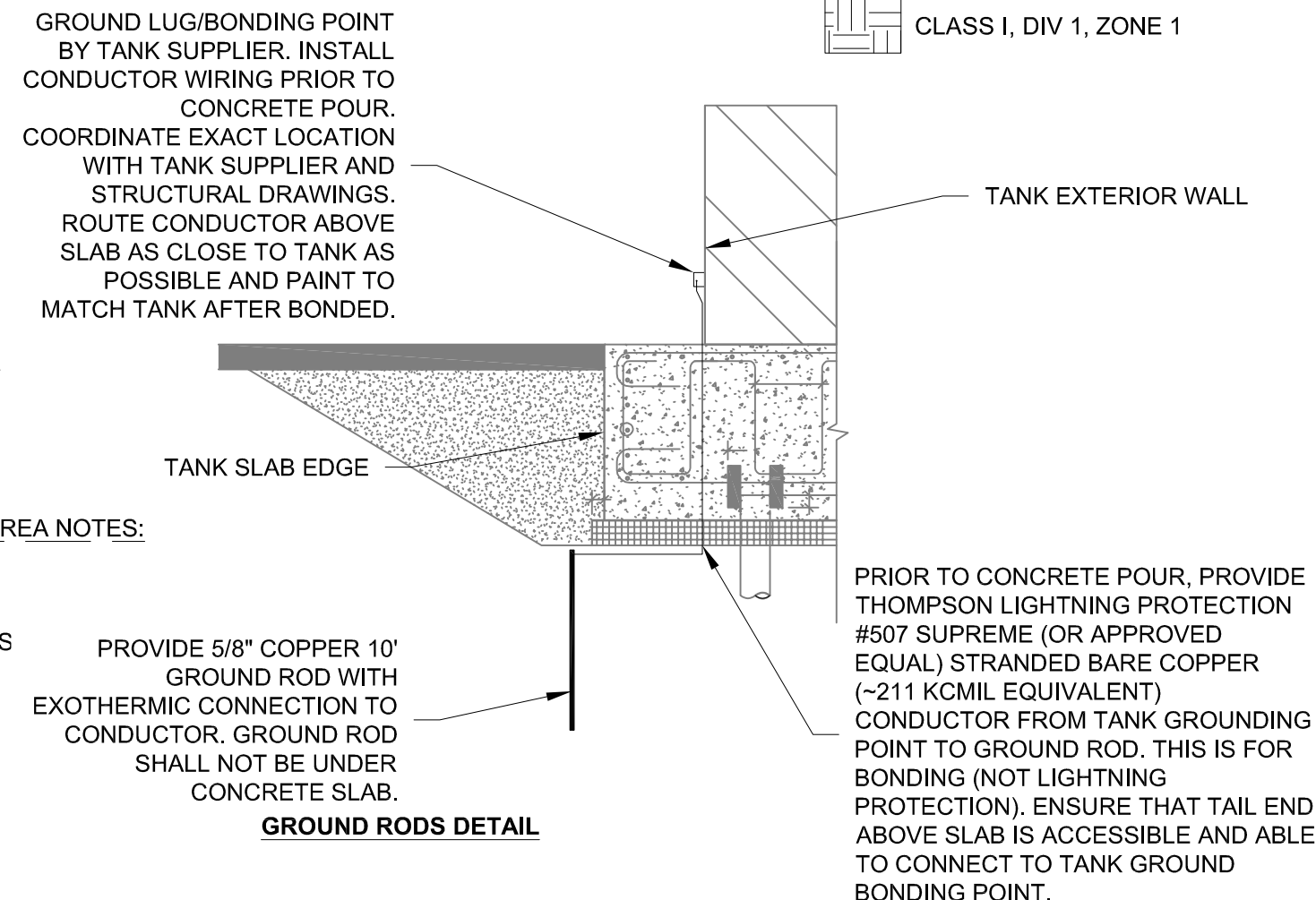
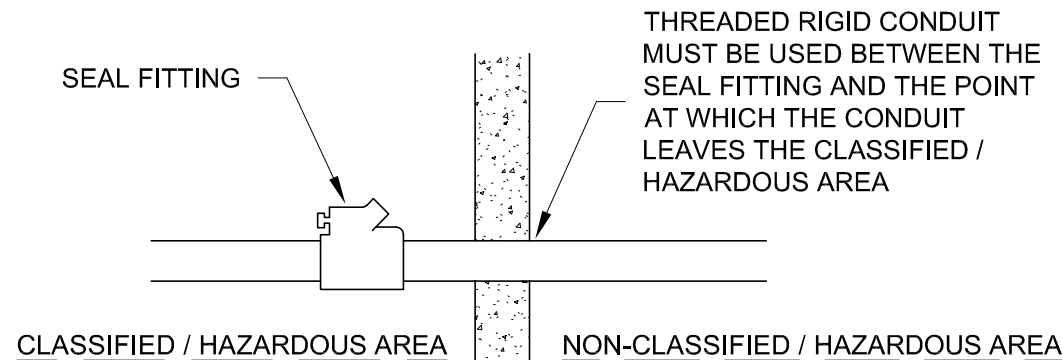
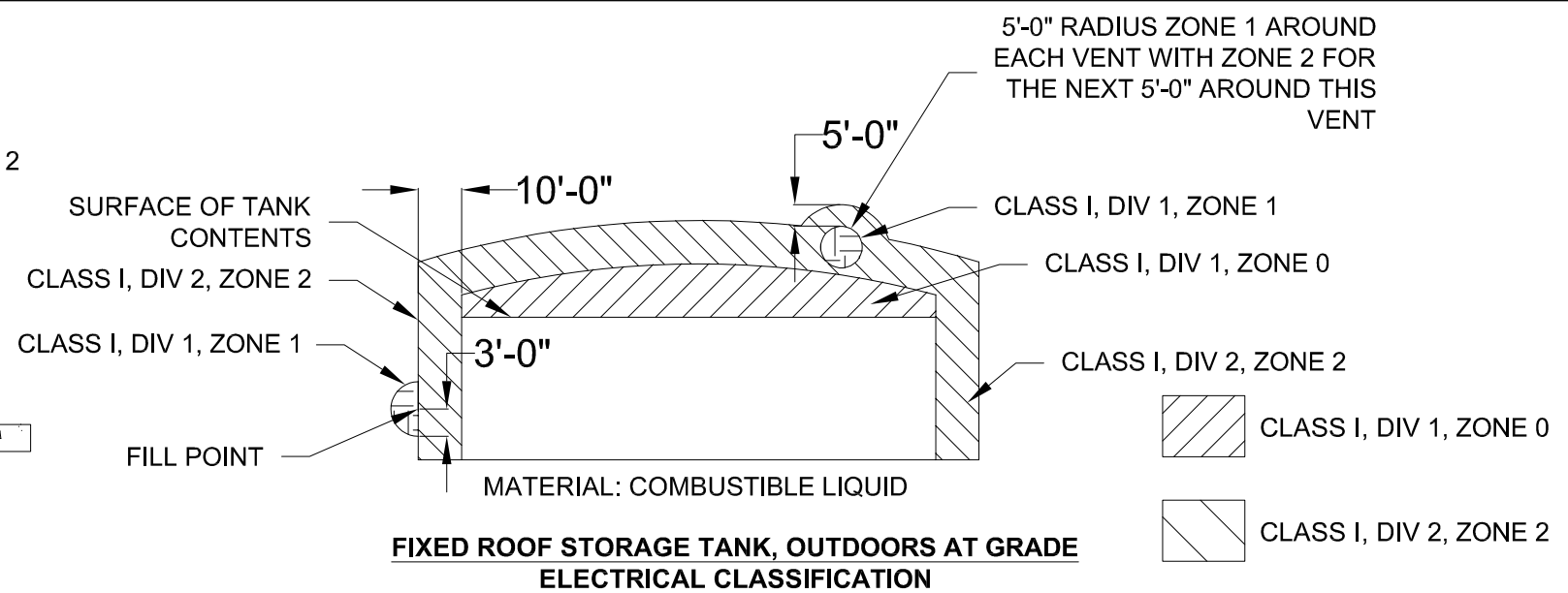
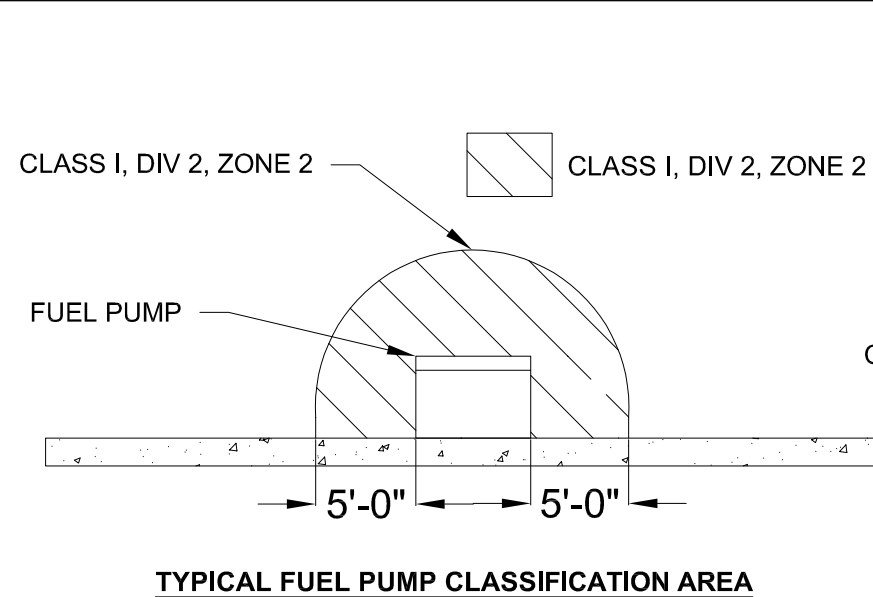

HAZARDOUS AREA NOTES:

- A. ELECTRICAL INSTALLATION IN AREA DESIGNATED SHALL FOLLOW ALL RULES AND INTENT OF THE NATIONAL ELECTRICAL CODE FOR AREAS DESIGNATED CLASSIFIED / HAZARDOUS
- B. ALL CONDUIT ROUTED WITHIN OR THROUGH A CLASSIFIED AREA SHALL BE THREADED RIGID GALVANIZED CONDUIT.
- C. ALL CLASSIFIED / HAZARDOUS SEALS SHALL BE ACCESSIBLE.
- D. BOXES, FITTINGS AND JOINTS ARE NOT REQUIRED TO BE EXPLOSION PROOF EXCEPT WHEN EXPLOSION PROOF ENCLOSURES ARE REQUIRED BECAUSE THEY CONTAIN CONTROL DEVICES, CIRCUIT BREAKERS, MOTOR STARTERS, ALARMS OR OTHER SIMILAR DEVICES THAT HAVE MAKE-AND-BREAK CONTACTS
- E. WHERE POSSIBLE, THE ELECTRICAL CONTRACTOR SHALL INSTALL ALL DEVICES AND ROUTE ALL CONDUIT OUTSIDE OF THE DEFINED CLASSIFIED / HAZARDOUS SPACE.

NON-CLASSIFIED / NON-HAZARDOUS AREA NOTES:

- A. NO UNION, COUPLING, BOX OR FITTING IN CONDUIT PERMITTED BETWEEN SEALING FITTING AND POINT WHERE CONDUIT LEAVES THE HAZARDOUS AREA.

NOT FOR CONSTRUCTION - FOR BID ONLY

I HEREBY CERTIFY THAT THIS PLAN, SPECIFICATION OR REPORT WAS PREPARED BY ME OR UNDER MY DIRECT SUPERVISION AND THAT I AM A DULY REGISTERED PROFESSIONAL ENGINEER UNDER THE LAWS OF MINNESOTA.

NICHOLAS OELKE

DATE _____ REG. NO. 47135

IFB	4/29/2025	TJW	RJJ	ISSUED FOR BID
REV.	DATE	PREP. BY	CHK'D BY	DESCRIPTION



EVER-GREEN ENERGY™

DES COAL SUNSETTING

ELECTRIC AND COMMUNICATIONS DETAILS

DESIGN BY: RJJ DATE: 4/29/25
DRAWN BY: TJW DATE: 4/29/25

HORZ: N.T.S.

Project No. EGE0103

Sheet No. E400

VFD Schedule

VFD UNIT #/ TAG	EQUIPMENT SERVED	MOTOR DATA			ENCLOSURE RATING	HARMONIC MITIGATION	INTEGRAL DISCONNECT	BYPASS	MOTOR HEATER	VFD ISOLATION SWITCH	COMMUNICATIONS	VFD MIN. SCCR	BASIS OF DESIGN (SERIES)	NOTES
		QTY	VOLTAGE	HP (EA)										
BOILER 1 FD FAN VFD	BOILER 1 FD FAN	1	460V	75	UL TYPE 12	ACTIVE FRONT END	CIRCUIT BREAKER	RVSS	NO	YES	TBD	40 KA	ABB ACH580-3BCR-096A-4+B056+F267+G390	1, 2, 3, 4, 5, 6, 7, 8, 9, 10, 11, 12, 13, 14, 15, 16
BOILER 1 ID FAN VFD	BOILER 1 ID FAN	1	460V	100	UL TYPE 12	ACTIVE FRONT END	CIRCUIT BREAKER	RVSS	NO	YES	TBD	50 KA	ABB ACH580-3BCR-124A-4+B056+F267+G390	1, 2, 3, 4, 5, 6, 7, 8, 9, 10, 11, 12, 13, 14, 15, 16

VFD SCHEDULE NOTES:

- AT MINIMUM, VFD SHALL INCLUDE 5% IMPEDANCE VIA 5% AC LINE REACTOR OR DUAL DC BUS CHOKES SIZED TO 5% EQUIVALENT IMPEDANCE. VFD INPUT AMPS SHALL NOT EXCEED VFD OUTPUT AMPS.
- PROVIDE UL1449 SURGE PROTECTIVE DEVICE (SPD).
- PROVIDE WITH ALPHA-NUMERIC KEYPAD INTERFACE. PROVIDE DISPLAY IN PLAIN ENGLISH (NOT CODE & LOOKUP DRIVEN).
- PROVIDE INTERNAL EMI/RFI FILTER PER IEC 61800-3.
- VFD SHALL BE BTL LISTED FOR BACNET MS/TP AND SHALL INCLUDE MODBUS RTU. WHERE LISTED COMMUNICATIONS IS TBD, PROVIDE AS REQUIRED FOR CONTROLS ON-SITE.
- PROVIDE REAL TIME CLOCK WITH BATTERY BACKUP (INCLUDE 10-YEAR BATTERY).
- PROVIDE PHASE LOSS PROTECTION & BROKEN BELT (LOSS OF LOAD) INDICATION WHILE IN BYPASS.
- BYPASS CONTACTORS SHALL BE POWERED BY SWITCH MODE POWER SUPPLY, ALLOWING +/-30% INPUT VOLTAGE TOLERANCE. (120V CPT NOT ALLOWED).
- VFD AND BYPASS SHALL BOTH INCLUDE BACNET MS/TP, DAMPER CONTROL AND FIREMAN'S OVERRIDE FUNCTIONALITY.
- BYPASS OPERATION SHALL AUTO-RESET AFTER A BROWN-OUT CONDITION.
- INCLUDE FAST ACTING DRIVE ISOLATION FUSES.
- BYPASS SHALL BE FULLY FUNCTIONAL IN THE EVENT OF A VFD FAILURE. BYPASS SHALL NOT RELY ON THE VFD OR THE VFD'S CONTROL BOARD/RELAYS.
- VFD SHALL LIMIT TH(D) TO 3% OR LESS AT INPUT LUGS, WHILE AT FULL SPEED/LOAD. VFD SHALL INCLUDE DC BUS CAPACITORS AND LCL FILTER.
- VFD SHALL PROVIDE AN OUTPUT VOLTAGE EQUAL TO THE MOTOR NAMEPLATE VOLTAGE, WHILE OPERATING AT FULL SPEED/LOAD. POWER FACTOR SHALL BE 1.0.
- VFD SHALL PROVIDE A PROGRAMMABLE BOOST FUNCTION THAT BOOSTS THE DC BUS VOLTAGE DURING A LOW LINE CONDITION. MINIMUM BOOST AMOUNT: 10%.
- SYSTEM SHALL MEET IEEE 519 BASED ON THE HARMONIC MITIGATION METHOD(S) IDENTIFIED IN SCHEDULE.

MOTOR AND EQUIPMENT WIRING SCHEDULE

UNIT NO./ TAG	DESCRIPTION	HP	KW	V/PH/Hz	FLA / MCA / MOC	MIN SCCR	CONTROLLER			DISCONNECT AT MOTOR				CONTROL BY	DUCT SMOKE DETECTORS	CONDUIT/CONDUCTOR SIZE & QUANTITY	PANEL NAME	CIRCUIT NUMBER(S)	OVERCURRENT PROTECTION AMP/POLE	NOTES
							TYPE	SIZE	FURN. BY	NEMA	SIZE	FURN. BY	FUSE SIZE							
BOILER 1 FD FAN	FORCED DRAFT FAN	75	-	480/3/60	96A / 120A / 125A	40 KA	VFD	75HP	DIV 26	12	-	INT W/VFD	PER VFD MFR	DIV 26 & 23	N/A	2" C - 3#1/0, 1#6G	A-SSBLL-1	VERIFY	125A/3P (250AF)	4
BOILER 1 ID FAN	INDUCED DRAFT FAN	100	-	480/3/60	124A / 155A / 200A	50 KA	VFD	100HP	DIV 26	12	-	INT W/VFD	PER VFD MFR	DIV 26 & 23	N/A	2.5" C - 3#3/0, 1#4G	A-SSBLL-1	VERIFY	200A/3P (400AF)	5
OIL PUMP-4	FUEL OIL PUMP	5	-	480/3/60	7.6A / 9.5A / 15A	8 KA	FVNR	0	DIV 26	12 OR 3R	30A	DIV 26	TBD	DIV 26 & 23	N/A	3/4" C - 3#10, 1#10G	MCC-2	VERIFY	20A/3P	2,6
OIL PUMP-5	FUEL OIL PUMP	5	-	480/3/60	7.6A / 9.5A / 15A	8 KA	FVNR	0	DIV 26	12 OR 3R	30A	DIV 26	TBD	DIV 26 & 23	N/A	3/4" C - 3#10, 1#10G	A-SSB1-2	VERIFY	20A/3P	3,6
FUEL OIL MONITOR CTRL PNL	FUEL TANK MONITORING	-	1.5	120/1/60	12.5A / - / 20A	5 KA	N/A	N/A	N/A	N/A	N/A	N/A	N/A	DIV 26 & 23	N/A	3/4" C - 2#10, 1#10G	MCC-2 BREAKER PANEL	20	20A/1P	1
BOILER 1 BURNER CTRL PNL	BOILER BURNER CONTROL	-	1.5	120/1/60	12.5A / - / 20A	5 KA	N/A	N/A	N/A	N/A	N/A	N/A	N/A	DIV 26 & 23	N/A	3/4" C - 2#12, 1#12G	MCC-2 BREAKER PANEL	22	20A/1P	1
BOILER 2 BURNER CTRL PNL	BOILER BURNER CONTROL	-	1.5	120/1/60	12.5A / - / 20A	5 KA	N/A	N/A	N/A	N/A	N/A	N/A	N/A	DIV 26 & 23	N/A	3/4" C - 2#12, 1#12G	A-SLD1-1A	27	20A/1P	7
BOILER 3 BURNER CTRL PNL	BOILER BURNER CONTROL	-	1.5	120/1/60	12.5A / - / 20A	5 KA	N/A	N/A	N/A	N/A	N/A	N/A	N/A	DIV 26 & 23	N/A	3/4" C - 2#10, 1#10G	A-SLD1-1A	29	20A/1P	7
BOILER 4 BURNER CTRL PNL	BOILER BURNER CONTROL	-	1.5	120/1/60	12.5A / - / 20A	5 KA	N/A	N/A	N/A	N/A	N/A	N/A	N/A	DIV 26 & 23	N/A	3/4" C - 2#10, 1#10G	A-SLD1-1A	38	20A/1P	7

GENERAL MOTOR AND EQUIPMENT SCHEDULE NOTES:

- DIVISION 26 CONTRACTOR TO VERIFY EQUIPMENT SPECIFICATION INFORMATION WITH CORRESPONDING MECHANICAL SCHEDULES AND SHOP DRAWINGS PRIOR TO INSTALLATION.
- DIVISION 23 CONTRACTOR SHALL BE RESPONSIBLE FOR HANDLING AND INSTALLATION OF ALL MECHANICAL EQUIPMENT LISTED UNLESS NOTED OTHERWISE.
- DIVISION 26 CONTRACTOR TO SHALL BE RESPONSIBLE FOR PROVIDING REQUIRED ELECTRICAL INTERCONNECTING POWER WIRING BETWEEN STARTER/VFD'S, CONTROLS, DISCONNECTS AND CONNECTIONS TO MECHANICAL EQUIPMENT LISTED UNLESS NOTED OTHERWISE.
- ALL EQUIPMENT SIZES, LOADS, HP RATINGS, CIRCUIT BREAKER SIZES, STARTER SIZES, CONNECTION TYPE, AND CONDUIT/WIRE SIZES ARE AS PER THE SIZES AND BASIS OF DESIGN EQUIPMENT COORDINATED DURING DESIGN WITH THE VARIOUS DISCIPLINES. ALL REVISIONS AFTER BID (PER EQUIPMENT SUBMITTALS AND ACTUAL SUPPLIED EQUIPMENT) SHALL BE CONSOLIDATED INTO A SINGLE CONFIRMING RFI SUBMITTED BY THE ELECTRICAL CONTRACTOR SHOWING REDLINED PROPOSED REVISIONS TO BE REVIEWED BY EGE.

SPECIFIC MOTOR AND EQUIPMENT SCHEDULE NOTES:

- WITHIN EXISTING 100A, 208/120V, 10KA EATON PRL1A (WITHIN MCC-2) 'MCC-2 BREAKER PANEL', PROVIDE 20A/1P BREAKER FOR CONTROL PANEL. REPLACE SPARE 20A/2P BREAKER IN CKT 20,22 WITH TWO 20A/1P BREAKERS (SALVAGE BREAKER TO TURN OVER TO OWNER). PROVIDE LABEL AND UPDATED PANEL SCHEDULE.
- WITHIN EXISTING 600A, 480V, 65KA EATON FREEDOM 2100 MCC (CAT #CGSC-15574-MCC) 'MCC-2', PROVIDE 20A/3P 65KA BREAKER FOR OIL PUMP AND INSTALL IN EXISTING SPACE (OR REPLACE SPARE FUSED SWITCH). PROVIDE ENGRAVED LABEL TO MATCH EXISTING LABELS TO NOTE "OIL PUMP 4".
- WITHIN EXISTING 1600A, 480/277V SQUARE D QED-2 SWITCHBOARD 'A-SSB1-2' UTILIZE SPARE 20A/3P BREAKER FOR OIL PUMP. PROVIDE ENGRAVED LABEL TO MATCH EXISTING LABELS TO NOTE "OIL PUMP 5".
- WITHIN EXISTING 2000A, 480/277V SQUARE D QED 2 SWITCHBOARD 'A-SSBLL-1' UTILIZE EXISTING SPARE POWERPACT J250 LSI (250A FRAME) BREAKER FOR FD FAN. SET BREAKER AT 125A. PROVIDE ENGRAVED LABEL TO MATCH EXISTING LABELS TO NOTE "BOILER 1 FD FAN". PROVIDE PIN REDUCERS AS REQUIRED FOR TERMINATION AT CIRCUIT BREAKER LUGS.
- WITHIN EXISTING 2000A SQUARE D QED 2 SWITCHBOARD 'A-SSBLL-1' UTILIZE EXISTING SPARE POWERPACT LJ400 LSI (400A FRAME) BREAKER FOR ID FAN. SET BREAKER AT 200A. PROVIDE ENGRAVED LABEL TO MATCH EXISTING LABELS TO NOTE "BOILER 1 ID FAN".
- PROVIDE 600V, 30A FUSED STARTER/DISCONNECTS FOR FUEL OIL PUMP. COORDINATE WITH SKID SUPPLIER FOR DIVISION OF WORK. 5HP IS ESTIMATED PUMP SIZE. PROVIDE EXACT FUSE AND MOTOR OVERLOAD SIZE BASED ON EXACT PUMP SELECTION.
- WITHIN EXISTING 600A, 208/120V, 10KA, SQUARE-D I-LINE HC4286WP PANEL 'A-SLD1-1A', PROVIDE 20A/1P QO BREAKER FOR BOILER BURNER CONTROL PANEL. VERIFY CIRCUIT NUMBERS. PROVIDE LABEL AND UPDATED PANEL SCHEDULE.

NOT FOR CONSTRUCTION - FOR BID ONLY

I HEREBY CERTIFY THAT THIS PLAN, SPECIFICATION OR REPORT WAS PREPARED BY ME OR UNDER MY DIRECT SUPERVISION AND THAT I AM A DULY REGISTERED PROFESSIONAL ENGINEER UNDER THE LAWS OF MINNESOTA.

NICHOLAS OELKE

DATE _____ REG. NO. 47135

IFB	4/29/2025	TJW	RJJ	ISSUED FOR BID
REV.	DATE	PREP. BY	CHK'D BY	DESCRIPTION



DES COAL SUNSETTING

ELECTRIC SCHEDULE

DESIGN BY: RJJ DATE: 4/29/25
DRAWN BY: TJW DATE: 4/29/25

HORZ: N.T.S.

Project No. EGE0103

Sheet No. E900

MARKS AND SYMBOLS LEGEND:

MARKS:

B1001	CONCRETE BEAM MARK NUMBER
B1001-PT	POST TENSIONED CONCRETE BEAM MARK NUMBER
BP1	BEARING / BASE PLATE MARK NUMBER
BRF1	BRACE FRAME MARK NUMBER
BR1	MILD STEEL BOTTOM REINFORCING MARK NUMBER
C1	COLUMN MARK NUMBER
CC1	CONCRETE COLUMN MARK NUMBER
CW1	CONCRETE WALL NUMBER
D1	STEEL DECK MARK NUMBER
DC1	DROP CAPITAL MARK NUMBER
DP1	DRILLED PIER MARK NUMBER
DPC1	DRILLED PIER CAP NUMBER
EP1	EMBEDDED PLATE MARK NUMBER
F1	SPREAD FOOTING MARK NUMBER
GB1	GRADE BEAM MARK NUMBER
H1	HEADER MARK NUMBER
HCP	HOLLOW CORE PLANK
HD1	HOLD DOWN MARK NUMBER
J10	JOIST MARK NUMBER
L1	LINTEL MARK NUMBER
MC1	MASONRY COLUMN MARK NUMBER
MF1	MOMENT FRAME MARK NUMBER
MW1	MASONRY WALL NUMBER
P1	PIER MARK NUMBER
PC1	PILE CAP MARK NUMBER
RD1	ROOF DECK MARK NUMBER
S1	SLAB MARK NUMBER
SC1	STEEL COLUMN MARK NUMBER
SR1	STUD RAIL REINFORCING MARK NUMBER
SW1	SHEAR WALL MARK NUMBER
T1	TRUSS MARK NUMBER
TR1	MILD STEEL TOP REINFORCING MARK NUMBER
W1	WALL MARK NUMBER
WC1	WOOD COLUMN MARK NUMBER
WF1	WALL FOOTING MARK NUMBER
WO1	WEB OPENING

GENERAL SYMBOLS:

	APPROXIMATE LOCATION OF DRAIN TILE
	MATCH LINE
	LINE OF DEMOLITION
	SLAB STEP LOCATION WITH ELEVATIONS
	SLAB STEP LOCATION
	CHANGE IN SLAB SLOPE
	CHANGE IN SLAB THICKNESS
	KEYNOTE MARK NUMBER
	NEW BUILDING GRID LINE
	EXISTING BUILDING GRID LINE
	ELEVATION MARKER
	SHADED AREA INDICATES CUT THROUGH EXISTING CONSTRUCTION
	SHADED AREA INDICATES PROJECTION OF EXISTING CONSTRUCTION
	WALL MARK NUMBER OR WALL TYPE
	APPROXIMATE LOCATION OF UTILITY PIPE PENETRATION THROUGH FOUNDATION WALL
	FOOTING STEP LOCATION
	APPROXIMATE LOCATION OF SOIL BORING
	COMPRESSION PILE
	TENSION / COMPRESSION PILE
	TEST PILE
	SPAN DIRECTION OF ELEMENT
	EXTENT OF ELEMENT
	CONTINUOUS EXTENT OF ELEMENT
	DETAIL CALLOUT
	ELEVATION CALLOUT

PLAN SYMBOLS LEGEND:

FOUNDATION SYSTEM:

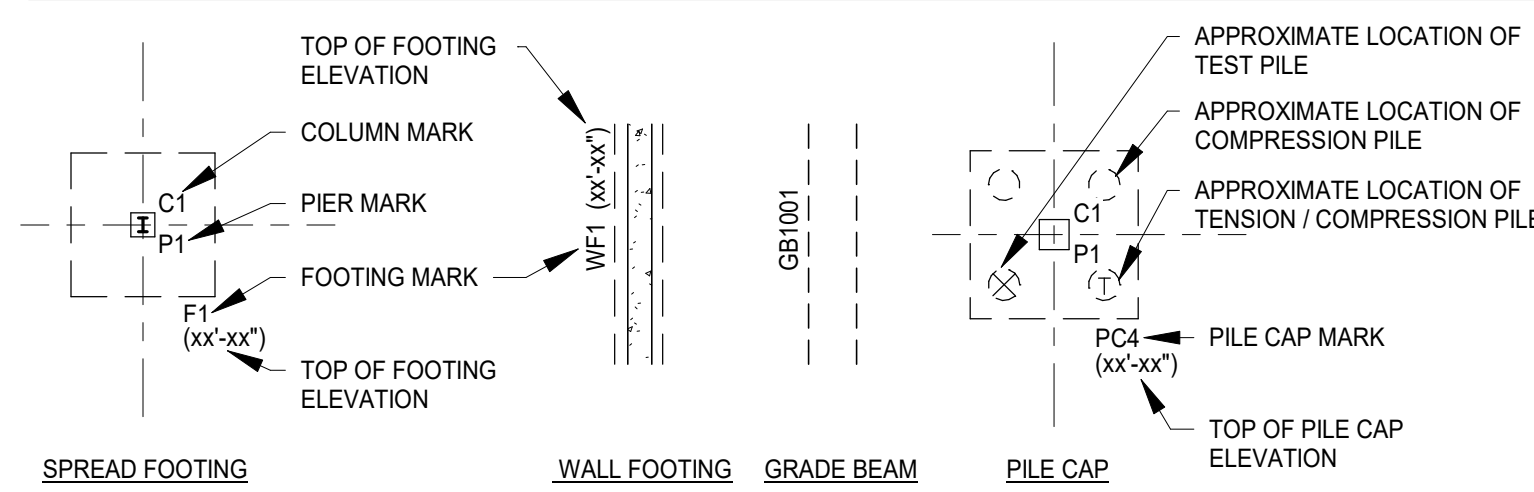

SHEET LIST	
SHEET #	SHEET NAME
S001	LEGEND SHEET
S002	GENERAL STRUCTURAL NOTES
S201	FOUNDATION PLAN
S202	FIRST FLOOR FRAMING PLAN
S501	STRUCTURAL DETAILS

STRUCTURAL ABBREVIATIONS:

A		G		Q	
ADDL	ADDITIONAL	GA	GAGE/GAUGE	QTY	QUANTITY
ADJ	ADJACENT	GALV	GALVANIZED	R	
ALT	ALTERNATE	GB	GRADE BEAM		
ALUM	ALUMINUM	GC	GENERAL CONTRACTOR	R	RADIUS
AR	ANCHOR ROD	GLB	GLUE LAMINATED BEAM	RD	ROOF DRAIN
ARCH	ARCHITECT	GLC	GLUE LAMINATED COLUMN	REF	REFERENCE
B		GLT	GLUE LAMINATED TIMBER	REINF	REINFORCEMENT/REINFORCING
BDE	BOTTOM OF DECK ELEVATION	GR	GRADE	REQD	REQUIRED
BFE	BOTTOM OF FOOTING ELEVATION	GSN	GENERAL STRUCTURAL NOTES	RO	ROUGH OPENING
BM	BEAM	GSW	GYPSON WALL BOARD	RSS	RUGGED STRUCTURAL SCREW
BOL	BOTTOM OF LINTEL	H		RTU	ROOF TOP UNIT
BOT	BOTTOM	HK	HOOK	S	
BP	BEARING PLATE / BASE PLATE	HORIZ	HORIZONTAL	SB	SOIL BORING
BR	BOTTOM REINFORCING	HSA	HEADED STUD ANCHOR	SC	SLIP CRITICAL
BTWN	BETWEEN	HSS	HOLLOW STRUCTURAL SHAPE	SCHED	SCHEDULE
C		HT	HEIGHT	SER	STRUCTURAL ENGINEER OF RECORD
CA	COLUMN ABOVE	I		SF	SQUARE FOOT
CANTL	CANTILEVER	ID	INSIDE DIAMETER	SIM	SIMILAR
CB	COLUMN BELOW	INCL	INCLUDE	SL	SLAB ON GRADE
CFS	COLD-FORMED STEEL	ISF	INSIDE FACE	SOG	SLAB ON GRADE
CGS	CENTER OF GRAVITY STRAND	J		SPA	SPACES
CIP	CAST IN PLACE	JT	JOINT	SPEC	SPECIFICATION
CJ	CONTROL JOINT	JBE	JOIST BEARING ELEVATION	SPF	SPRUCE PINE FIR
CJP	COMPLETE JOINT PENETRATION	K		SS	STAINLESS STEEL
CL	CENTER LINE	K		SSLT	SHORT-SLOT LOAD TRANSVERSE
CLR	CLEAR	K		STD	STANDARD
CLT	CROSS LAMINATED TIMBER	K	KIPS	STIFF	STIFFENER
CMU	CONCRETE MASONRY UNIT	KLF	KIPS PER LINEAL FOOT	STL	STEEL
COL	COLUMN	KSF	KIPS PER SQUARE FOOT	STRUCT	STRUCTURE / STRUCTURAL
CONC	CONCRETE	KSI	KIPS PER SQUARE INCH	SYM	SYMMETRICAL
CONN(S)	CONNECTION(S)	KO	KNOCK OUT	SYP	SOUTHERN YELLOW PINE
CONST	CONSTRUCTION	L		T	
CONT	CONTINUOUS	LB(S)	POUND(S)	T/G	TONGUE AND GROOVED
COSP	CODE OF STANDARD PRACTICE	LL	LIVE LOAD	TBE	TOP OF BEAM ELEVATION
D		LLH	LONG LEG HORIZONTAL	TDE	TOP OF DECK ELEVATION
d	NAIL DIAMETER	LLV	LONG LEG VERTICAL	TEMP	TEMPORARY
db	BAR DIAMETER	LONG	LONGITUDINAL	TFE	TOP OF FOOTING ELEVATION
DBA	DEFORMED BAR ANCHOR	LSL	LAMINATED STRAND LUMBER	TGBE	TOP OF GRADE BEAM ELEVATION
DBL	DOUBLE	LSH	LONG SIDE HORIZONTAL	TPCE	TOP OF PILE CAP ELEVATION
DEG	DEGREE	LSV	LONG SIDE VERTICAL	TPCPE	TOP OF PRECAST PLANK ELEVATION
DEMO	DEMOLITION	LWT	LIGHT WEIGHT	TPE	TOP OF PIER ELEVATION
DF	DOUGLAS FIR-LARCH	LVL	LAMINATED VENEER LUMBER	TR	TOP REINFORCING
DIA	DIAMETER	M		TRANS	TRANSVERSE
DIAG	DIAGONAL	MAX	MAXIMUM	TSE	TOP OF SHEATHING ELEVATION
DIM	DIMENSION	MECH	MECHANICAL	TSE	TOP OF SLAB ELEVATION
DL	DEAD LOAD	MEP	MECHANICAL, ELECTRICAL & PLUMBING	TSE	TOP OF SUBFLOOR ELEVATION
DLT	DOWEL LAMINATED TIMBER	MEZZ	MEZZANINE	TWE	TOP OF WALL ELEVATION
E		MFR	MANUFACTURER	TYP	TYPICAL
EA	EACH	MIN	MINIMUM	U	
EF	EACH FACE	MISC	MISCELLANEOUS	UNO	UNLESS NOTED OTHERWISE
EL	ELEVATION	MSR	MACHINE STRESS RATED	URM	UNREINFORCED MASONRY
ELEC	ELECTRICAL	MTL	METAL	V	
ELEV	ELEVATOR	N		VERT	VERTICAL
EJ	EXPANSION JOINT	NIC	NOT IN CONTRACT	W	
EMBED	EMBEDMENT	N-S	NORTH - SOUTH DIRECTION	W/	WITH
EQ	EQUAL	NLT	NAIL LAMINATED TIMBER	W/O	WITHOUT
EQUIP	EQUIPMENT	NTS	NOT TO SCALE	WD	WOOD
ES	EACH SIDE	NWT	NORMAL WEIGHT	WF	WIDE FLANGE
EW	EACH WAY	O		WL	WIND LOAD
E-W	EAST - WEST DIRECTION	OC	ON CENTER	WP	WORK POINT
(E)	EXISTING	OD	OUTSIDE DIAMETER	WT	WEIGHT
EXP	EXPANSION	OSF	OUTSIDE FACE	WWR	WELDED WIRE REINFORCING
F		OPNG	OPENING		
FDN	FOUNDATION	OPR	OPPOSITE		
FD	FLOOR DRAIN	OIO	OUT TO OUT		
FFE	FINISHED FLOOR ELEVATION	P			
FLR	FLOOR	PAF	POWER ACTUATED FASTENER		
FLR	FLOOR	PC	PRECAST CONCRETE		
FS	FOOTING STEP	PL	PLATE		
FT	FEET	PLF	POUNDS PER LINEAL FOOT		
FTG	FOOTING	PLYWD	PLYWOOD		
FV	FIELD VERIFY	PRE FAB	PREFABRICATED		
		PROJ	PROJECTION		
		PSF	POUNDS PER SQUARE FOOT		
		PSI	POUNDS PER SQUARE INCH		
		PSL	PARALLEL STRAND LUMBER		
		PT	POST TENSIONED		

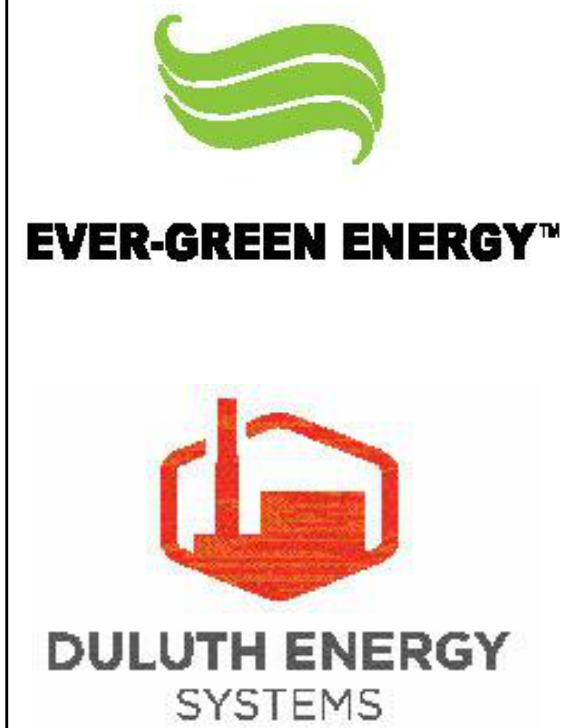

DULUTH ENERGY SYSTEMS - FUEL OIL TANK FOUNDATION

TEL: 818 702 1058
mbjeng.com
501 LAKE AVENUE S
SUITE 200
DULUTH, MN 55802

REVISIONS

#	REV	DATE

NOT FOR CONSTRUCTION - FOR BID ONLY

Issue:	FOR BID
Commission #:	D25.302.0
Date:	04/30/25
Checked By:	BWH
Drawn By:	SJL

Sheet Title:
LEGEND SHEET

Sheet Number:
S001

TYPICAL NOTES:

These notes specify the requirements for the design represented in these documents. The construction and materials shall comply with all the pertinent codes and references, plans, and details, including (but not limited to) those shown in architectural, civil, mechanical and electrical drawings.

The Contractor shall verify all dimensions and existing conditions in the field that affect construction prior to commencing work on the affected element or shop drawing submittals. Resolve any discrepancies with the Architect prior to construction.

The contract structural drawings and specifications represent the completed structure. The Contractor is responsible for bracing and shoring (without overstressing) all structural elements as necessary at any stage of construction until completion of the project. The Structural Engineer of Record is not responsible for the Contractor's means, methods, sequences or procedures of construction. Contractor shall recognize and consider effects of thermal movements of structural elements during construction period.

The Contractor is solely responsible for site safety including all temporary precautionary measures and safety programs. Site observation visits by the Structural Engineer of Record do not include review of the contractor's safety precautions.

Refer to architectural, mechanical and electrical drawings for locations, elevations, dimensions, and details of sleeves, inserts, openings, recesses, curbs, housekeeping pads, etc. that are not shown on the structural drawings and do not damage structural members.

Information shown in the structural drawings regarding existing conditions represents the current and general field conditions related to the new work, to the best of our knowledge. Report all discrepancies (unforeseen conditions) to the Architect for resolution prior to performing related new work.

Requests for information shall be submitted in writing and shall reference the part of the construction documents that is in question.

SPECIAL INSPECTIONS:

Special inspections required by the building code and these documents shall be provided in addition to inspections to be performed by the city in which the project is located.

Contractor shall read and understand their duties in the specification and under the building code for special inspections and coordinate as necessary the Owner's responsibilities.

The Special Inspectors shall be provided by the Owner and shall use current structural drawings incorporating all revisions and approved shop drawings.

Special inspection reports are to be submitted promptly and within 24 hours to the Structural Engineer of Record and Contractor from the time when inspections are performed.

The General Contractor shall provide timely notice (minimum 24 hours) to the Special Inspector and sufficient time for the Inspector to perform their inspection.

For a schedule of Special Structural Inspections required by the building code for this project, see the Special Inspection Schedule.

STRUCTURAL TEST AND SPECIAL INSPECTION SCHEDULE:

Table with columns: Item, Continuous, Periodic, None. Rows include STEEL CONSTRUCTION, CONCRETE CONSTRUCTION, MASONRY CONSTRUCTION, WOOD CONSTRUCTION, SOILS, and DRIVEN DEEP FOUNDATION ELEMENTS.

- Notes:
1. When the fabricator does not meet the requirements of 1704.2.5.1.
2. Empirically designed masonry is excluded.

SHOP DRAWINGS:

Submit shop drawing schedule with construction schedule that includes consideration for review period. See specification for additional information.

General contractor shall submit shop drawings in digital format (.pdf) for structural review. Digital drawings shall meet the following requirements.

- 1. All pages are rotated, printed to scale with searchable text.
2. All transmittals shall be located as the first page of the submittal or as a separate file within one digital package.
3. Contractor digital review comments and their digital stamp shall be attached. Our review will not occur until the contractor has reviewed, coordinated with other trades and provided shop stamp.
4. MBJ will mark-up the digital set in red and return a digital file via email, ftp site or other means.

Under no circumstances will MBJ review shop drawings that are considered to be scanned/copied construction document submittals. The Detailer shall produce and submit original documents for review.

DESIGN CODES AND STANDARDS:

2018 International Building Code, as amended and adopted by the State of Minnesota.

MATERIAL PROPERTIES:

Table with columns: Material, Typical, Weldable, Cast-in-Place Concrete (fc) at 28 days, UNO, Structural Steel (Fy), Angles, Channels, Plates, and Bars.

DESIGN LOADS:

LATERAL LOADS:

Risk Category: IV
Wind Loads:
Primary Frame Wind Data:
Basic Wind Speed: V ult = 119 mph

Exposure Category: D
Velocity Pressure Coefficient (Kz): 1.126
Directionality (Kd): 0.95
Force Coefficient (Cf): 0.89

Components and Cladding Wind Loads:
Exterior Component/Cladding: Supplier to develop based on code criteria and indicate on shop drawings.

Seismic Loads:
Primary Seismic Data: No design required

LATERAL LOAD RESISTING SYSTEM:

The tank is a standalone structure. All connections to concrete pile cap by tank supplier.

GRAVITY LOADS:

Dead Load:
Fuel Oil Tank: 100,000 lbs (based on preliminary estimate per Ever-Green Energy)

Live Load:
Fuel Oil: 410,000 lbs (per Ever-Green Energy)

Snow Load:
Ground Snow Load, Pg: 60 psf
Flat-Roof Snow Load, Pf: 60 psf
Snow Exposure Factor, Ce: 1.0
Snow Load Importance Factor, I: 1.2
Thermal Factor, Ct: 1.2

FOUNDATIONS:

Refer to geotechnical report number 01-20551 by American Engineering Testing, Inc., dated December 17, 2019 (driven pile pile recommendations are not included in final report, but can be found in draft report dated August 8, 2019).

The Contractor shall verify the location of all existing and new underground utilities and tanks prior to beginning excavation.

For underground utilities adjacent to foundations and through foundations reference drawings for typical detail showing step footings below utilities as required to avoid undermining of structure by utilities.

DRIVEN PILES:

The foundation system shall be supported by driven steel pipe piling based on the preliminary Geotechnical Recommendations.

Piles are designed for a maximum net capacity of 75 tons per pile (working load) with no down drag load. Maximum net capacities shall have a minimum factor of safety of 2.0.

Piles are designed for a maximum uplift load of 4 Tons per pile (working load).

Piles are designed for a maximum lateral load of 1 Ton per pile (working load).

Minimum steel pipe properties shall be: 7" diameter x 0.408" wall thickness; ASTM A252, Grade 3; Fy = 45 ksi.

Pipe piles shall be driven with a closed end consisting of a 1" thick end plate. The pile shall be prepared for full penetration welding to the end plate or with commercially fabricated point reinforcement as require by the Geotechnical Engineer.

All connection splices between pile sections shall be full penetration welds unless noted otherwise on plans.

All pipe piles shall be filled with concrete.

Reference the drawings for estimated pile lengths and/or estimated pile tip elevations.

Provide test piles as directed by the Geotechnical Engineer. Test piles that comply with the project documents may be used in the completed work. Reference drawings for test pile locations.

See project specification for required pile driving criteria, pile test program, coordination meetings, notification requirements, seismic monitoring, and condition surveys of adjacent structures.

Pre-drilling may be necessary to facilitate installation (obstructions) and/or mitigate vibrations during pile driving. Contractor shall include pre-drilling if field conditions dictate this need.

REINFORCED CONCRETE:

The detailing, fabrication and erection of all reinforcing shall be done in accordance with the latest edition of ACI-315, "Manual of Standard Practice for Detailing Reinforced Concrete Structures and ACI-318, "Building Code Requirements for Structural Concrete."

All reinforcing bars are deformed and continuous, unless noted otherwise. Refer to drawings for reinforcing lap length schedule.

Provide suitable wire spacers, chairs, etc. for support of reinforcing steel in proper position while placing concrete. All bars shall be tied to prevent displacement while placing concrete. All chairs and slab bolsters shall be plastic or steel with plastic tips. When reinforcing steel is epoxy coated or p/t tendons are fully encapsulated, all chairs and slab bolsters shall be epoxy coated or plastic and all support bars shall be epoxy coated. Chairs are to be stable and resist tipping.

The fabricator shall submit a complete list of accessories and placing details with the shop drawings.

No horizontal construction joints shall be placed in beams, joists, or slabs, unless shown on drawings.

Locate vertical construction joints in beams and slabs at central one third of span. Refer to drawings for details. Submit proposed construction joint locations to the Structural Engineer of Record for review prior to placement of concrete. Where new concrete is placed against existing concrete, the existing concrete shall be roughened to a minimum 1/4" amplitude.

Refer to drawings for placement guidelines of embedded pipes, sleeves, and conduits. Conduits are not permitted in slabs 3 inches or less in thickness.

Conduit and piping shall be fabricated and installed so that cutting, bending, or displacement of reinforcement from its specified location is not required.

Concrete cover for pipe embedments with their fittings shall be at least 1-1/2 in. For concrete exposed to earth or weather, and at least 3/4 in. For concrete not exposed to weather, or not in contact with ground

Aluminum conduit, aluminum sleeves and aluminum embeds are not permitted in concrete.

All conduits shall be placed within the middle one-third of the slab thickness.

The maximum size of conduits shall be 1 1/4" diameter and shall be spaced no closer (to each other or reinforcing steel) than 4 inches unless prior approval is obtained from the structural engineer.

Sleeves and conduits shall pass perpendicularly through beams in the center third of the beam's depth. Embedded boxes shall not be located on the bottom face of beams and shall meet clearance requirements for beam reinforcing tendons and reinforcing steel.

Embedded boxes, sleeves and conduits shall not be placed within a distance of 2'-6" from the face of any column and shall not be placed within 1'-6" of any anchor without prior approval from the structural engineer.

In areas of high conduit concentration where it is not possible to meet the above requirements, consult the structural engineer prior to placement.

Provide a 3/4 inch chamfer for all exposed concrete corners. See architectural drawings for details and additional requirements.

Formwork and all shoring for flatwork shall be left in place until the concrete reaches at least 75 percent of the 28-day compressive strength. Design of shoring and reshoring is the responsibility of the Contractor and shall conform to ACI 347R and ACI 347.2R.

Concrete compressive strength testing used to determine flatwork stripping times shall be performed using one of the following methods:

CIPPOC and standard cylinders cured and stored in the same conditions as the flatwork.

Maturity testing properly calibrated and conducted by an approved testing agency.

Calcium chloride is not permitted as a concrete additive.

Concrete Cover on Reinforcing:

Topping Slab: 3/4" clear top
Slab on Grade: 2" clear top
Concrete covers are intended to meet 2 hour rating requirements of IBC Section 721.1 prescriptive fire protection.

Footings and Caissons: 3" clear bottom and sides
2" clear top
#5 and smaller 1 1/2" clear earth or weather face
#6 and greater 2" clear earth or weather face
3/4" interior face

Columns and Beams: 1 1/2" clear to ties or stirrups
1" clear top
3/4" clear bottom and sides
1" clear top

Slabs: 3/4" clear bottom carbonate aggregate
1" clear bottom siliceous aggregate



EVER-GREEN ENERGY™



DULUTH ENERGY SYSTEMS

MBJ

TEL: 818.702.2058
mbjeng.com
502 LAKE AVENUE S
SUITE 200
DULUTH, MN 55802

DULUTH ENERGY SYSTEMS - FUEL OIL TANK FOUNDATION

REVISIONS

REV DATE

NOT FOR CONSTRUCTION - FOR BID ONLY

Issue: FOR BID

Commission #: D25.302.0

Date: 04/30/25

Checked By: BWH

Drawn By: SJL

Sheet Title: GENERAL STRUCTURAL NOTES

Sheet Number:

S002



EVER-GREEN ENERGY™



DULUTH ENERGY SYSTEMS

MBJ

TEL: 818.702.2058
mbjeng.com
501 LAKE AVENUE S
SUITE 200
DULUTH, MN 55802

DULUTH ENERGY SYSTEMS -
FUEL OIL TANK FOUNDATION

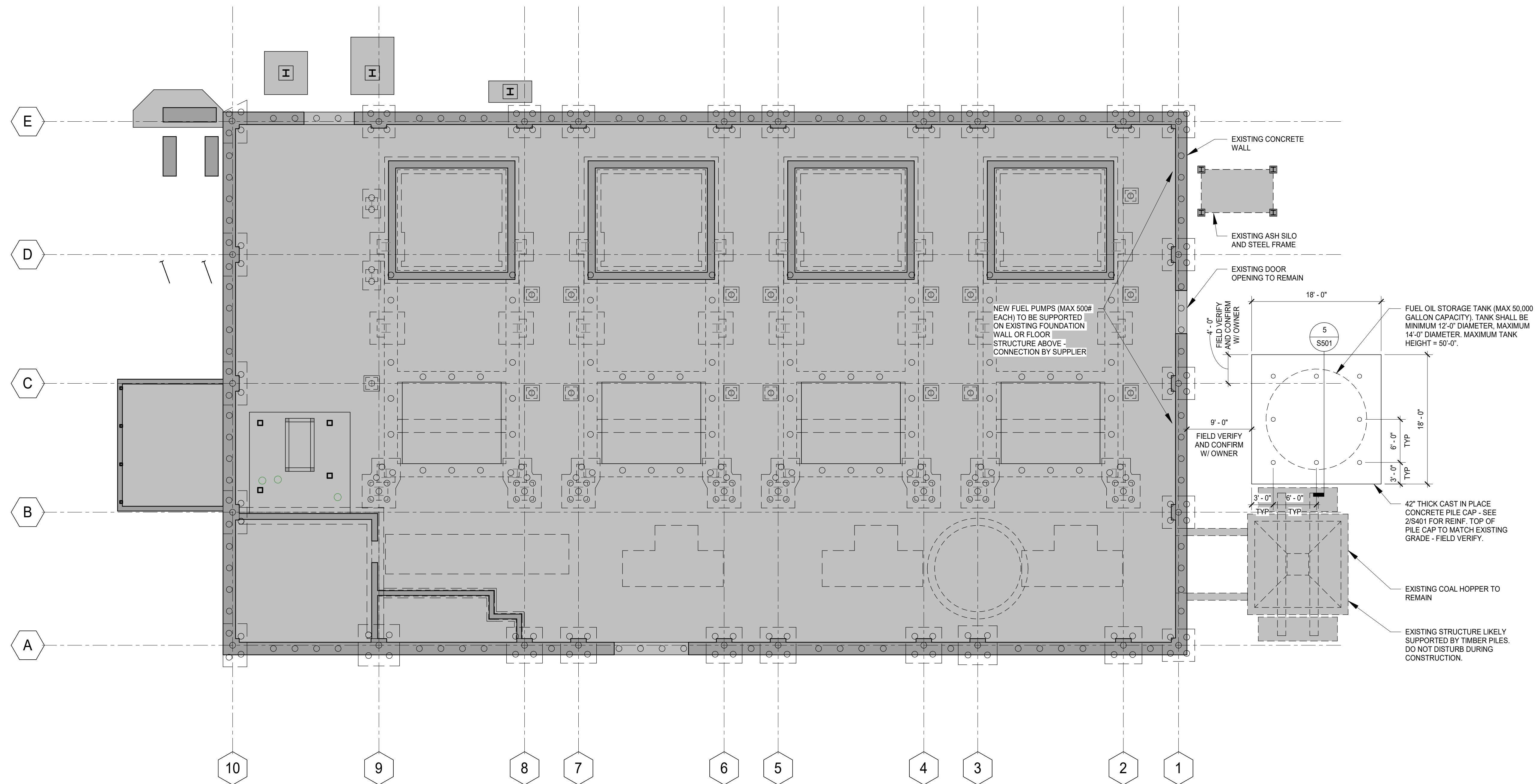

1 FOUNDATION PLAN
1/8" = 1'-0"

PLAN NOTES (UNLESS NOTED OTHERWISE):

- EXISTING CONDITIONS DOCUMENTED HEREIN ARE BASED ON ORIGINAL BUILDING DRAWINGS BY SULLIVAN & ORRFALT ARCHITECTS DATED 1932. IT IS LIKELY MODIFICATIONS HAVE BEEN MADE TO EXISTING STRUCTURE. CONTRACTOR SHALL FIELD VERIFY EXISTING STRUCTURE PRIOR TO CONSTRUCTION. NOTIFY ENGINEER OF RECORD IF EXISTING CONDITIONS CONFLICT WITH CONSTRUCTION DOCUMENTS.
- DRIVEN PIPE PILES DESIGN CRITERIA AS FOLLOWS:
 - MINIMUM 75 TON PER PILE (WORKING LOAD) TO BEDROCK. MINIMUM FACTOR OF SAFETY = 2.0.
 - REFER TO GENERAL STRUCTURAL NOTES FOR GEOTECHNICAL REPORT, PILE TYPE, UPLIFT AND LATERAL CAPACITY.
 - ANTICIPATE APPROXIMATELY 50 TO 60 FEET TO TIP ELEVATION.
 - CONFIRM THE NEED FOR A TEST PILE(S) WITH PROJECT GEOTECHNICAL ENGINEER.
 - PER THE PRELIMINARY GEOTECHNICAL REPORT, SOILS SHALL BE EXPECTED TO BE MODERATELY CORROSIVE. VERIFY REQUIREMENTS WITH PROJECT GEOTECHNICAL ENGINEER.
 - PILING CONTRACTOR SHALL PROVIDE FINAL PILE CAPACITY IN COORDINATION WITH SPECIAL INSPECTOR AND GEOTECHNICAL ENGINEER.
 - PRIOR TO PLACEMENT OF PILE CAP, FINAL PILE CONFIGURATION SHALL BE SURVEYED, AND SURVEY RESULTS SHALL BE SUBMITTED TO STRUCTURAL ENGINEER TO VERIFY PILE CAP DESIGN. STRUCTURAL ENGINEER SHALL REVIEW AND MODIFY PILE CAP (IF REQUIRED) FOR AS-BUILT PILING CONFIGURATION.
- FOLLOWING EXCAVATION FOR NEW FOUNDATIONS, REPLACE PAVING PER OWNER'S REQUIREMENTS.

REVISIONS

#	REV	DATE

**NOT FOR
CONSTRUCTION
- FOR BID ONLY**

Issue: FOR BID

Commission #: D25.302.0

Date: 04/30/25

Checked By: BWH

Drawn By: SJL

Sheet Title:
FOUNDATION PLAN

Sheet Number:
S201



EVER-GREEN ENERGY™



DULUTH ENERGY SYSTEMS

MBJ

TEL: 818.702.0066
mbjeng.com
501 LAKE AVENUE S
SUITE 200
DULUTH, MN 55802

DULUTH ENERGY SYSTEMS -
FUEL OIL TANK FOUNDATION

REVISIONS

#	REV	DATE

NOT FOR CONSTRUCTION - FOR BID ONLY

Issue:	FOR BID
Commission #:	D25.302.0
Date:	04/30/25
Checked By:	BWH
Drawn By:	SJL

Sheet Title:
FIRST FLOOR FRAMING PLAN

Sheet Number:
S202

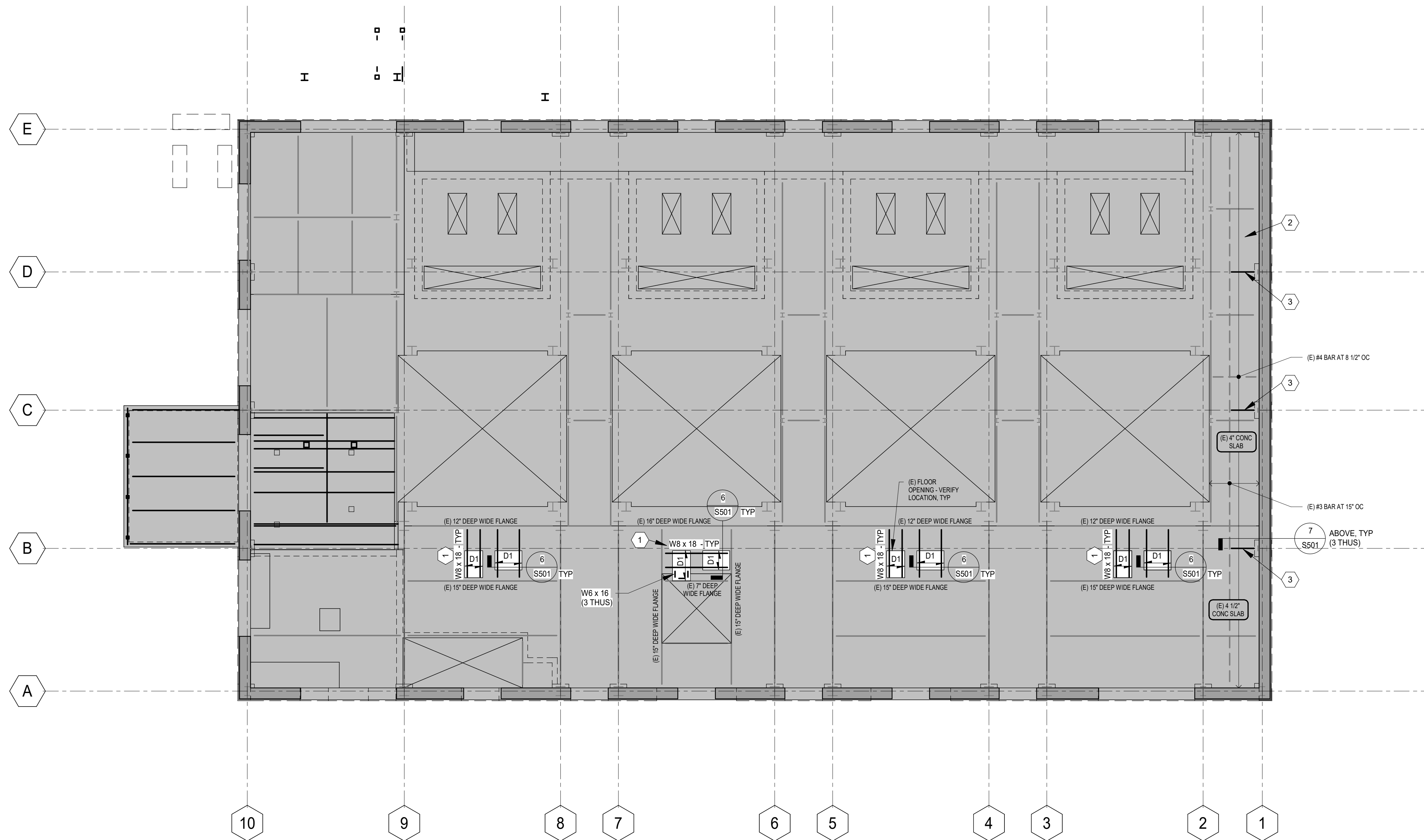

1 FIRST FLOOR FRAMING PLAN
1/8" = 1'-0"

PLAN NOTES (UNLESS NOTED OTHERWISE):

- TOP OF SLAB ELEVATION (TSE) = 626'-11" (FIELD VERIFY), UNLESS NOTED OTHERWISE ON PLAN.
- TOP OF BEAM ELEVATION (TBE) = 626'-6 1/2" (FIELD VERIFY), UNLESS NOTED OTHERWISE ON PLAN AS (XX'-XX").
- SEE THE GENERAL STRUCTURAL NOTES FOR STEEL BEAM CONNECTION REQUIREMENTS.
- SEE S501 FOR TYPICAL STEEL CONNECTION SCHEDULES AND DETAILS.
- D1 = INFILL EXISTING FLOOR OPENING WITH 1 1/2" - 16 GAUGE COMPOSITE FLOOR DECK + 2 1/2" MINIMUM, 4" MAXIMUM NORMAL WEIGHT CONCRETE. (MATCH EXISTING SLAB THICKNESS) - MAXIMUM 6'-0" DECK SPAN. NOTIFY ENGINEER OF RECORD IF CONCRETE THICKNESS OR DECK SPAN EXCEEDS MAXIMUM. ABUT NEW SLAB WITH EXISTING - SEE DETAIL 6/ S501.

KEYNOTES:

- SINGLE ANGLE CONNECTION TO EXISTING BEAM WEB (SEE SCHEDULE AND TYPICAL DETAIL). FIELD DRILL HOLES IN EXISTING BEAM WEB. FIELD WELD ALL LEGS (HORIZONTAL AND VERTICAL) OF SINGLE ANGLE CONNECTION (1/4" FILLET WELD) TO NEW STEEL BEAM.
- NEW 5" DIAMETER (MAXIMUM) OPENINGS MUST BE COORDINATED TO AVOID EXISTING REINFORCING STEEL IN EXISTING SLAB. GPR SCAN OR SIMILAR FLOOR BEFORE DRILLING NEW OPENING. DO NOT DAMAGE EXISTING REINFORCING STEEL.
- W18x35 CANTILEVER ABOVE FOR PIPE SUPPORT - VERIFY ELEVATION AND FINAL LOCATION WITH PLUMBING.

CONCRETE REINFORCING BAR LAP SPLICE SCHEDULE								
BAR SIZE	f _c = 3,000 PSI		f _c = 4,000 PSI		f _c = 5,000 PSI		f _c ≥ 6,000 PSI	
	CLASS A	CLASS B	CLASS A	CLASS B	CLASS A	CLASS B	CLASS A	CLASS B
#3	18"	22"	16"	20"	14"	18"	12"	16"
#4	22"	30"	20"	26"	18"	22"	16"	20"
#5	28"	36"	24"	32"	22"	28"	20"	26"
#6	34"	44"	30"	38"	26"	34"	24"	32"
#7	48"	64"	42"	54"	38"	50"	34"	44"
#8	56"	72"	48"	62"	44"	56"	40"	52"
#9	62"	82"	54"	70"	48"	64"	44"	58"
#10	70"	92"	62"	80"	54"	70"	50"	64"
#11	78"	102"	68"	88"	60"	78"	56"	72"

- NOTES:
- REINFORCING BAR LAP SPLICE SCHEDULE APPLIES TO UNCOATED, GRADE 60 REINFORCING BARS IN NORMAL WEIGHT CONCRETE.
 - PROVIDE CLASS A LAP UNLESS NOTED OTHERWISE.
 - FOR EPOXY COATED BAR, MULTIPLY THE ABOVE LENGTHS BY 1.5.
 - FOR LIGHT WEIGHT CONCRETE, MULTIPLY THE ABOVE LENGTHS BY 1.3.
 - FOR TOP BARS IN BEAMS AND HORIZONTAL WALL REINFORCING, MULTIPLY THE ABOVE LENGTHS BY 1.3.
 - MAXIMUM SPACING OF BARS BEING LAPPED IS ONE FIFTH THE LAP SPLICE LENGTH, NOT TO EXCEED 6".

1 REINFORCING BAR LAP SPLICE SCHEDULE
S501 NO SCALE

ALL-BOLTED SINGLE ANGLE CONNECTION SCHEDULE				
BEAM SIZE	ROWS OF BOLTS	ANGLE LENGTH (IN)		COMMENTS
	"N"	"L"		
W8, W10	2	5 1/2"		
W12, W14	3	8 1/2"		
W16	4	11 1/2"		
W18	5	14 1/2"		
W21	6	17 1/2"		
W24	7	20 1/2"		

- NOTES:
- SEE TYPICAL ALL-BOLTED SINGLE ANGLE CONNECTION DETAIL FOR ADDITIONAL INFORMATION.

2 TYPICAL ALL-BOLTED SINGLE ANGLE CONNECTION SCHEDULE
S501 NO SCALE

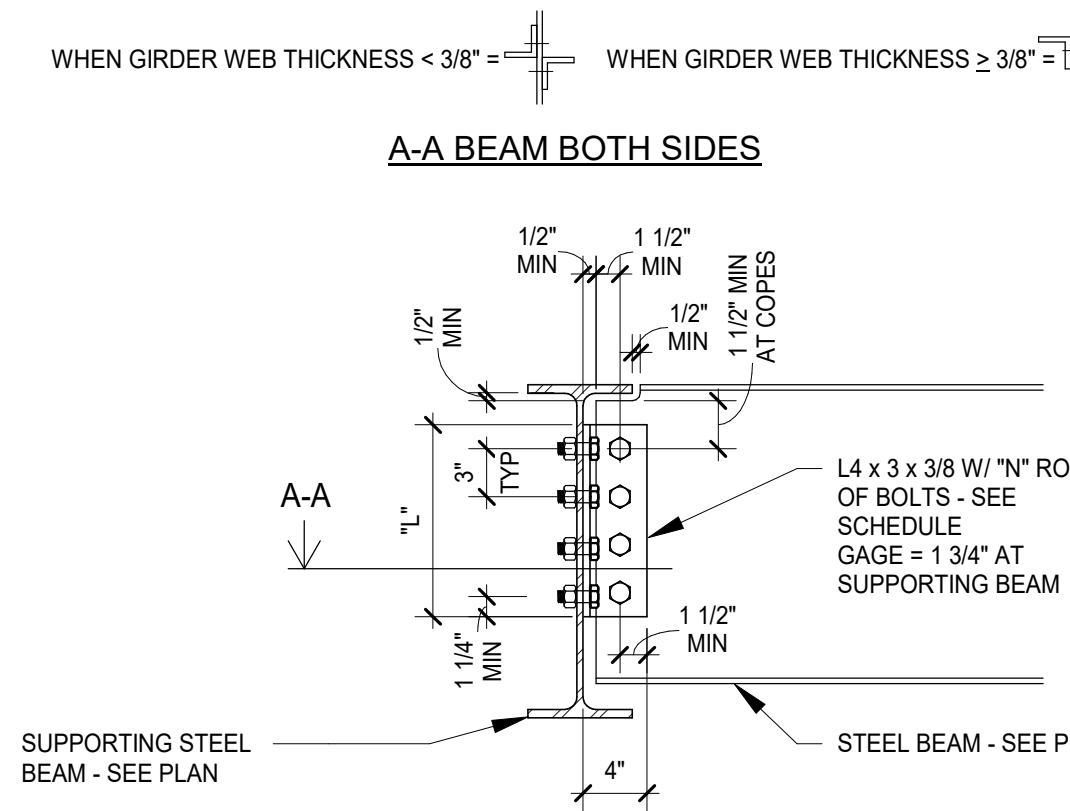

- NOTES:
- SINGLE ANGLE CONNECTIONS SHALL NOT BE USED AT BEAM TO COLUMN CONNECTIONS, AT THE ENDS OF SUPPORTING BEAMS (GIRDERS) OR AT THE ENDS OF PERIMETER (SPANDREL) BEAMS UNLESS NOTED OTHERWISE.
 - BOLTS SHALL BE 3/4" DIA ASTM A325 (OR F1852) IN STANDARD HOLES UNLESS NOTED OTHERWISE.
 - PROVIDE SHORT SLOT LOAD TRANSVERSE HOLES IN ANGLE LEG AT BEAM WEB.
 - SEE ALL-BOLTED SINGLE ANGLE CONNECTION SCHEDULE FOR ADDITIONAL INFORMATION.

3 TYPICAL ALL-BOLTED SINGLE ANGLE CONNECTION DETAIL
S501 NO SCALE

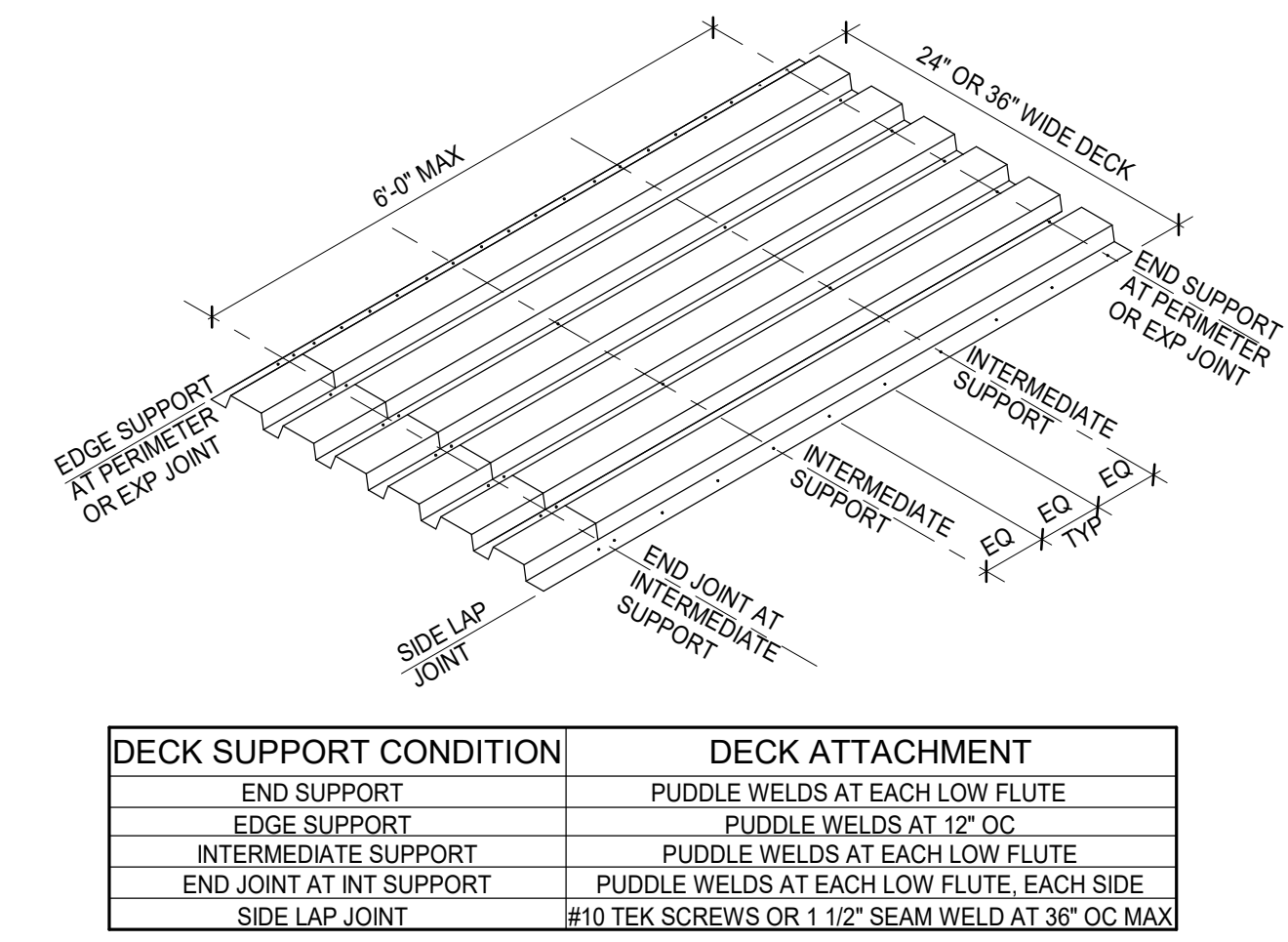

DECK SUPPORT CONDITION	DECK ATTACHMENT
END SUPPORT	PUDDLE WELDS AT EACH LOW FLUTE
EDGE SUPPORT	PUDDLE WELDS AT 12" OC
INTERMEDIATE SUPPORT	PUDDLE WELDS AT EACH LOW FLUTE
END JOINT AT INT SUPPORT	PUDDLE WELDS AT EACH LOW FLUTE, EACH SIDE
SIDE LAP JOINT	#10 TEK SCREWS OR 1 1/2" SEAM WELD AT 36" OC MAX

- NOTES:
- ALL PUDDLE (ARC-SPOT) WELDS SHALL BE 5/8" DIAMETER.
 - PROVIDE DECK ATTACHMENTS AT SPACING SHOWN UNLESS NOTED OTHERWISE ON DRAWINGS.
 - DECK SHEETS SHALL BE BUTTED AT END JOINTS. PROVIDE 1 1/2" MINIMUM BEARING.
 - HEADED STUD INSTALLED THROUGH THE DECK MAY BE SUBSTITUTED FOR PUDDLE WELD.

4 TYPICAL COMPOSITE FLOOR DECK ATTACHMENT DETAIL
S501 NO SCALE

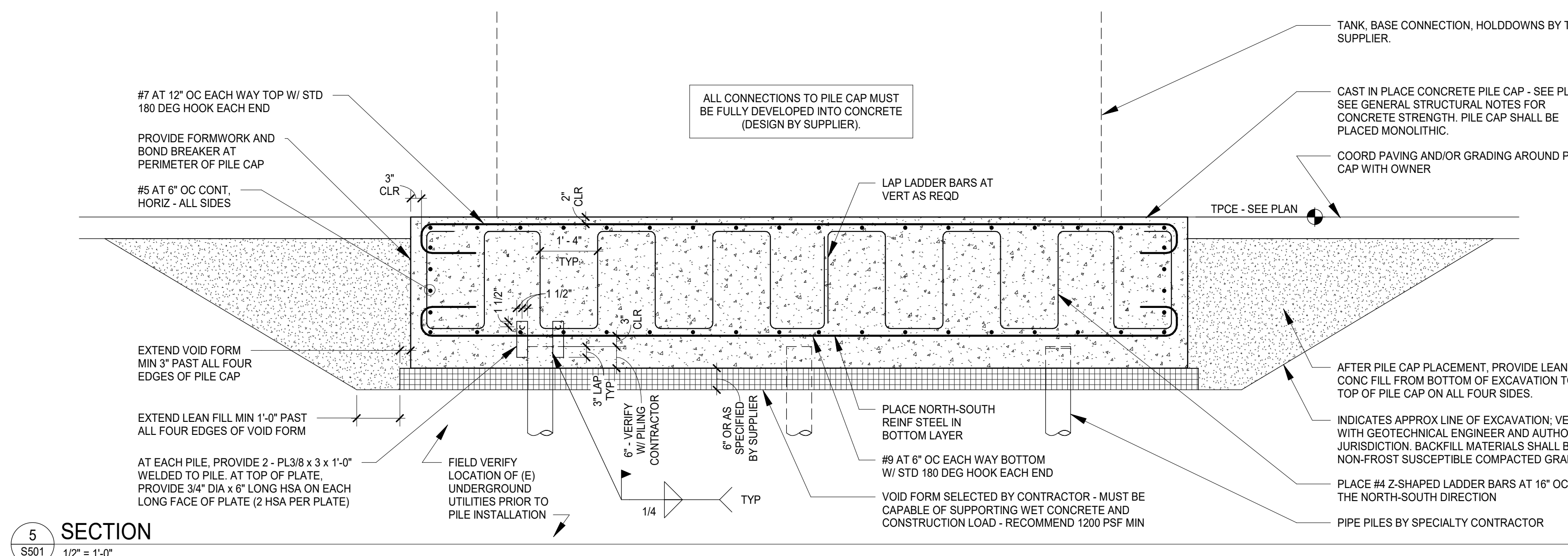

5 SECTION
S501 1/2" = 1'-0"

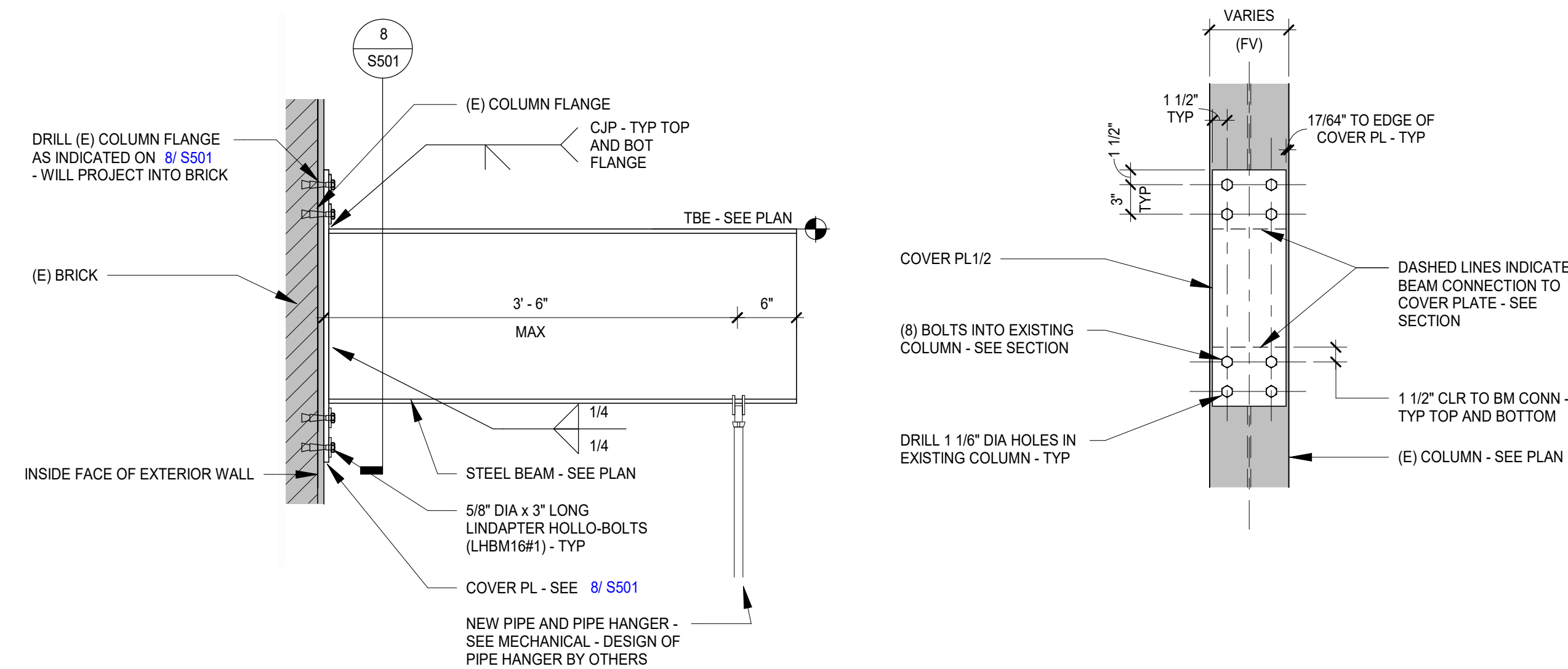

7 SECTION AT EXISTING EXTERIOR BUILDING COLUMN
S501 1" = 1'-0"

8 TYPICAL CONNECTION TO EXISTING COLUMN
S501 1" = 1'-0"

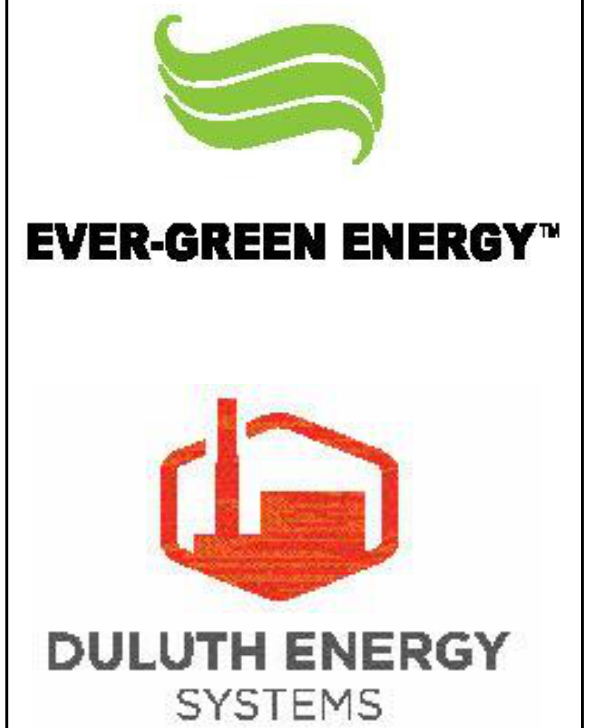

DULUTH ENERGY SYSTEMS - FUEL OIL TANK FOUNDATION

REVISIONS		
#	REV	DATE

NOT FOR CONSTRUCTION - FOR BID ONLY

Issue:	FOR BID
Commission #:	D25.302.0
Date:	04/30/25
Checked By:	BWH
Drawn By:	SJL
Sheet Title:	STRUCTURAL DETAILS
Sheet Number:	S501

Exhibit B

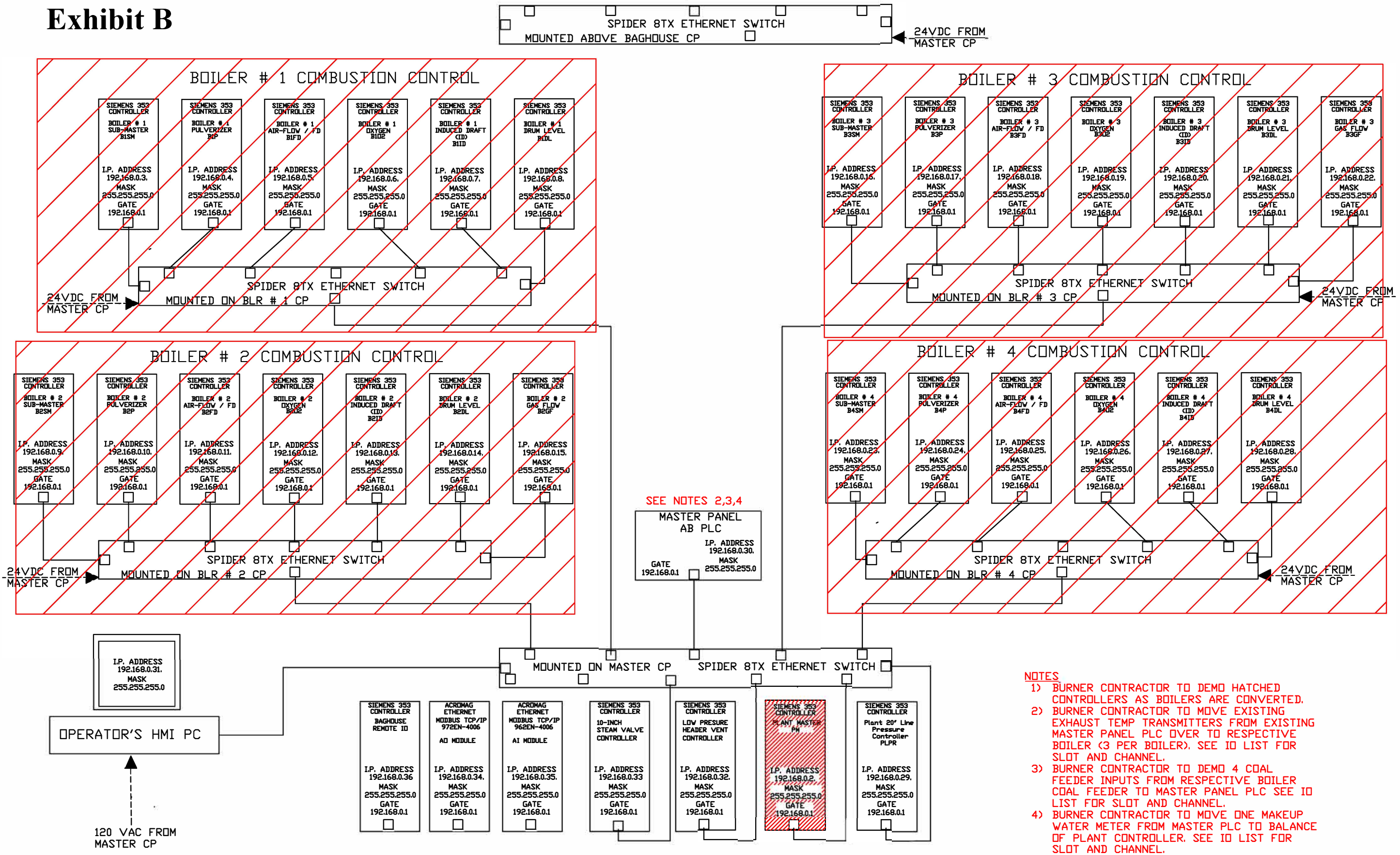

SEE NOTES 2,3,4

- NOTES**
- 1) BURNER CONTRACTOR TO DEMO HATCHED CONTROLLERS AS BOILERS ARE CONVERTED.
 - 2) BURNER CONTRACTOR TO MOVE EXISTING EXHAUST TEMP TRANSMITTERS FROM EXISTING MASTER PANEL PLC OVER TO RESPECTIVE BOILER (3 PER BOILER). SEE IO LIST FOR SLOT AND CHANNEL.
 - 3) BURNER CONTRACTOR TO DEMO 4 COAL FEEDER INPUTS FROM RESPECTIVE BOILER COAL FEEDER TO MASTER PANEL PLC SEE IO LIST FOR SLOT AND CHANNEL.
 - 4) BURNER CONTRACTOR TO MOVE ONE MAKEUP WATER METER FROM MASTER PLC TO BALANCE OF PLANT CONTROLLER. SEE IO LIST FOR SLOT AND CHANNEL.

DULUTH STEAM, DULUTH, MN.			
SCALE: NONE	APPROVED BY:	DRAWN BY: ONC	
DATE: 1/03/06			
POWER PROCESS EQUIPMENT, INC. CHANHASSEN, MINNESOTA			
Ethernet Communications Detail			DRAWING NUMBER: 281195 Page20 Rev 1

DATE	DESC	BY	DATE	DESC	BY
REV 8			REV 4		
REV 7			REV 3		
REV 6			REV 2		
REV 5			REV 1	2/04/07	ADDED CONTROLLER AND PLC WILL A

Boiler 2 Gas

<i>PROJECT ACTION</i>	<i>IO TAG</i>	<i>Type</i>	<i>Controller</i>	<i>Loop</i>	<i>Controller IP</i>	<i>Channel</i>	<i>Type</i>	<i>0% (4mA)</i>	<i>100% (20mA)</i>	<i>Eng Units</i>	<i>Description</i>	<i>Operating Type</i>
Move to BOP CONTROLLER	QT001	Discrete Output	B2 GAS	Plant gas	192.168.0.15	DIN3	1 pulse = 0.1MCF			MCF	Total Plant Gas	For Information
Move to BOP CONTROLLER	RH	Analog Input	B2 GAS	RH-OAT	192.168.0.15	AINU1	4/20 mA	0	100	%	Relative Humidity	For Information
Move to BOP CONTROLLER	OAT	Analog Input	B2 GAS	RH-OAT	192.168.0.15	AINU2	4/20 mA	-40	140	degf	Outside Air Temp	For Information and Drives Baghouse steam valve.
Move to BOP CONTROLLER	Steam Valve to Baghouse	Discrete Output	B2 GAS	RH-OAT	192.168.0.15	ROUT	4/20 mA	0	1	open/closed	Steam Valve to Baghouse	Opens @ 40degf/ Closes at 45 dF. Fail Open 0= OPEN, 1= CLOSED

Master PLC

<i>Project Action</i>	<i>Controller</i>	<i>IO TYPE</i>	<i>DI</i>	<i>Description</i>
Demo	MicroLogix 1500	DI	I:0/0	PULSE INPUT- COAL FEEDER 1
	MicroLogix 1500	DI	I:0/1	PULSE INPUT- COAL FEEDER 2
	MicroLogix 1500	DI	I:0/2	PULSE INPUT- COAL FEEDER 3
	MicroLogix 1500	DI	I:0/3	PULSE INPUT- COAL FEEDER 4
Move to BOP Controller	MicroLogix 1500	DI	I:0/4	MAKEUP WATER METER PULSE- 74.80 GAL/PULSE
	MicroLogix 1500	DI	I:0/5	
	MicroLogix 1500	DI	I:0/6	
Move to respective Boiler Controller	MicroLogix 1500	AI	I:1.0	AI- SLOT 1 CH 0- BOILER 1 AIR HTR GAS INLET TEMP (4mA=4000=0 DEG F 20mA=20000=1000 F)
	MicroLogix 1500	AI	I:1.1	AI- SLOT 1 CH 1- BOILER 1 AIR HTR GAS OUTLET TEMP (4mA=4000=0 DEG F 20mA=20000=1000 F)
	MicroLogix 1500	AI	I:1.2	AI- SLOT 1 CH 2- BOILER 1 AIR HTR AIR OUTLET TEMP (4mA=4000=0 DEG F 20mA=20000=1000 F)
	MicroLogix 1500	AI	I:1.3	
Move to respective Boiler Controller	MicroLogix 1500	AI	I:1.4	AI- SLOT 1 CH 4- BOILER 2 AIR HTR GAS INLET TEMP (4mA=4000=0 DEG F 20mA=20000=1000 F)
	MicroLogix 1500	AI	I:1.5	AI- SLOT 1 CH 5- BOILER 2 AIR HTR GAS OUTLET TEMP (4mA=4000=0 DEG F 20mA=20000=1000 F)
	MicroLogix 1500	AI	I:1.6	AI- SLOT 1 CH 6- BOILER 2 AIR HTR AIR OUTLET TEMP (4mA=4000=0 DEG F 20mA=20000=1000 F)
Move to respective Boiler Controller	MicroLogix 1500	AI	I:2.0	AI- SLOT 2 CH 0- BOILER 3 AIR HTR GAS INLET TEMP (4mA=4000=0 DEG F 20mA=20000=1000 F)
	MicroLogix 1500	AI	I:2.1	AI- SLOT 2 CH 1- BOILER 3 AIR HTR GAS OUTLET TEMP (4mA=4000=0 DEG F 20mA=20000=1000 F)
	MicroLogix 1500	AI	I:2.2	AI- SLOT 2 CH 2- BOILER 3 AIR HTR AIR OUTLET TEMP (4mA=4000=0 DEG F 20mA=20000=1000 F)
	MicroLogix 1500	AI	I:2.3	
Move to respective Boiler Controller	MicroLogix 1500	AI	I:2.4	AI- SLOT 2 CH 4- BOILER 4 AIR HTR GAS INLET TEMP (4mA=4000=0 DEG F 20mA=20000=1000 F)
	MicroLogix 1500	AI	I:2.5	AI- SLOT 2 CH 5- BOILER 4 AIR HTR GAS OUTLET TEMP (4mA=4000=0 DEG F 20mA=20000=1000 F)
	MicroLogix 1500	AI	I:2.6	AI- SLOT 2 CH 6- BOILER 4 AIR HTR AIR OUTLET TEMP (4mA=4000=0 DEG F 20mA=20000=1000 F)