



**CITY OF DULUTH, MINNESOTA  
PUBLIC WORKS & UTILITIES DEPARTMENT  
ENGINEERING DIVISION**

# Engineering Guidelines

for  
Professional Engineering Services  
and  
Developments

**Updated March 8, 2022**

### CITY APPROVAL

DocuSigned by:

*Cari Pedersen*

3/8/2022

5CBDF26E53834EA...

APPROVED

CHIEF ENGINEER OF TRANSPORTATION

DATE

DocuSigned by:

*Eric R Shaffer*

3/8/2022

40F0E0ACF03C4AA...

APPROVED

CHIEF ENGINEER OF UTILITIES

DATE

DocuSigned by:

*Cindy Voigt*

3/8/2022

3CE00AC02DB9436...

APPROVED

CITY ENGINEER

DATE

## TABLE OF CONTENTS

<b>I.</b>	<b>INTRODUCTION</b> .....	<b>1</b>
<b>II.</b>	<b>DEVELOPMENT PROCEDURES AND REQUIREMENTS</b> .....	<b>2</b>
<b>A.</b>	<b>Memorandum of Understanding (MOU)</b> .....	<b>3</b>
<b>B.</b>	<b>Paying for Public Improvements</b> .....	<b>3</b>
1.	Public Improvements Made Privately .....	<b>3</b>
2.	Special Assessments .....	<b>5</b>
<b>III.</b>	<b>GENERAL ENGINEERING REQUIREMENTS</b> .....	<b>6</b>
<b>IV.</b>	<b>TRANSPORTATION REQUIREMENTS</b> .....	<b>7</b>
<b>A.</b>	<b>Local Street Design Standards</b> .....	<b>7</b>
1.	Boulevards .....	<b>8</b>
2.	Sidewalks .....	<b>8</b>
3.	Reconstructed Streets.....	<b>8</b>
4.	Historic Designation .....	<b>9</b>
<b>B.</b>	<b>Shared Use Path/Trail Section Requirements</b> .....	<b>9</b>
<b>C.</b>	<b>Typical Section Standards</b> .....	<b>9</b>
<b>D.</b>	<b>Driveways and Alleys</b> .....	<b>10</b>
<b>V.</b>	<b>UTILITIES REQUIREMENTS</b> .....	<b>10</b>
<b>A.</b>	<b>Natural Gas</b> .....	<b>11</b>
<b>B.</b>	<b>Water</b> .....	<b>12</b>
<b>C.</b>	<b>Wastewater Collection System</b> .....	<b>13</b>
<b>D.</b>	<b>Storm Water</b> .....	<b>14</b>
<b>VI.</b>	<b>VACATION AND EASEMENT REQUIREMENTS</b> .....	<b>26</b>
<b>VII.</b>	<b>PLAN SUBMITTAL REQUIREMENTS</b> .....	<b>26</b>
<b>VIII.</b>	<b>CONSTRUCTION INSPECTION</b> .....	<b>28</b>
<b>IX.</b>	<b>MATERIALS TESTING</b> .....	<b>28</b>
<b>X.</b>	<b>SHOP DRAWINGS</b> .....	<b>28</b>
<b>XI.</b>	<b>POST CONSTRUCTION SUBMITTALS</b> .....	<b>29</b>
<b>A.</b>	<b>Record Drawings</b> .....	<b>30</b>
1.	Record Drawing Requirements .....	<b>30</b>
2.	Structural Plans – Record Drawing Requirements.....	<b>31</b>
3.	Storm Water Management Facilities (BMPs) Operation and Maintenance Manual and Record Drawings.....	<b>32</b>
<b>B.</b>	<b>Electronic Survey Data Submittal</b> .....	<b>33</b>
<b>XII.</b>	<b>SURVEY REQUIREMENTS</b> .....	<b>34</b>
1.	Utilities.....	<b>34</b>
2.	Horizontal Control Points.....	<b>34</b>
3.	Bench Marks .....	<b>35</b>

4. Monuments .....	35
5. Final Project Control.....	35
<b>XIII. MISCELLANEOUS REQUIREMENTS .....</b>	<b>36</b>
<b>B. City Expenses.....</b>	<b>36</b>
<b>C. Warranty.....</b>	<b>36</b>
<b>APPENDIX.....</b>	<b>37</b>

## **APPENDICES**

APPENDIX A	
Example: Memorandum of Understanding (MOU).....	37
APPENDIX B	
Application to Make Public Improvements Privately.....	45
APPENDIX C	
Special Assessment Policy for New Development.....	47
APPENDIX D	
Example: Typical Sections.....	52
APPENDIX E	
City of Duluth Driveway Entrance Requirements.....	57
APPENDIX F	
Policy on the Issuance of Driveway Permits for Private Improvements in Right-of-Way.....	59
APPENDIX G	
Preparing and Recording Easements and Vacations.....	63
APPENDIX H	
Drainage Report Submittal Checklist.....	72
APPENDIX I	
Preliminary Design Submittal Worksheet.....	74
APPENDIX J	
MS4 Statement of Compliance.....	76
APPENDIX K	
Example: City of Duluth – Plan Sheet – Title Page.....	78
APPENDIX L	
Water Main Check-off List.....	80
APPENDIX M	
Water Valve, Hydrant Valve, Hydrant and Service Installation Records.....	82

APPENDIX N  
Duluth Sanitary Sewer Wye Record.....87

## I. INTRODUCTION

Welcome to the City of Duluth's Engineering Division!

The Engineering Division (Engineering) is part of the Public Works and Utilities Department in the City of Duluth. Engineering is responsible for overseeing design and construction of public projects located in and affecting the public right-of-way, including surface transportation, bridges, driveway and alley access, traffic signals, parking, and utility infrastructure.

Engineering establishes and ensures that design standards and construction specifications are observed. Engineering has a responsibility to the public at large to create and maintain a consistent and reliable utility and transportation system. This system is planned, designed, and constructed according to the latest design standards, and Engineering ensures that the infrastructure is constructed to the highest and most current standards.

Additionally, Engineering issues a variety of permits that affect the public infrastructure such as excavation in City right-of-way, driveway aprons, street and sidewalk obstruction, over-sized loads, new culverts, and sewer, water and gas main extensions and connections. Permits related to work performed on private property are administered by the Construction Services and Inspections Division.

In order to standardize engineering requirements for developers and engineers performing work within the City of Duluth, the *Engineering Guidelines for Professional Engineering Services and Developments (Guidelines)* were developed by the Engineering Division to assist and convey direction to developers, engineering professionals, project managers, contractors, and residents when their projects include construction or connection to public infrastructure facilities within the City of Duluth.

These *Guidelines* as well as the City's *Standard Construction Specifications* outline the standards required when developing and constructing a project in the City of Duluth. They should be incorporated into the preparation of plans and specifications for sanitary sewer, storm sewer and water quality improvements, water main, natural gas, trails, and street construction within the City of Duluth. Compliance with these documents will help provide quality projects and assure uniform performance standards for the citizens of Duluth, Minnesota, and can save considerable time during the development process.

The *Guidelines* serve as a general reference for engineering requirements in the design, plan, and specification preparation in an effort to facilitate consistent plan preparation and construction of public works and to improve the quality of plan submittal and subsequent review and approval time. The *Guidelines* also strives to clarify where Engineering fits in as a part of the greater project and land development process.

The *Engineering Guidelines for Professional Engineering Services and Developments* is a "living" document that will be updated and revised as necessary to facilitate the

development of projects within the City of Duluth. With this document, we hope you will better understand the requirements and more easily navigate Engineering.

City staff is available to answer your questions or concerns as the project progresses through the process. Engineering is located in Room 240, on the second floor of Duluth's City Hall. For general questions relating to this document, the Engineering Division, or any permits issued from this office, you may contact the front counter at (218) 730-5200.

If the Engineering staff cannot answer your questions, specific questions relating to transportation and utilities may be directed to:

Tom Pfeffer, PE  
Chief Engineer of Utilities  
411 West First Street, Room 240  
Duluth, MN 55802  
Phone: (218) 730-5104  
[tpfeffer@duluthmn.gov](mailto:tpfeffer@duluthmn.gov)

Cari Pedersen, PE  
Chief Engineer of Transportation  
411 West First Street, Room 240  
Duluth, MN 55802  
Phone: (218) 730-5091  
[cpedersen@duluthmn.gov](mailto:cpedersen@duluthmn.gov)

Questions may also be forwarded to the City Engineer:

Cindy Voigt, PE  
City Engineer  
411 West First Street, Room 240  
Duluth, MN 55802  
Phone: (218) 730-5071  
[cvoigt@duluthmn.gov](mailto:cvoigt@duluthmn.gov)

You may also visit our City website for a copy of this document and other information regarding City code and ordinances, zoning, planning, and much more at [www.duluthmn.gov](http://www.duluthmn.gov). We look forward to working with you to ensure your plan and project development experience in Duluth is a pleasant one.

## **II. DEVELOPMENT PROCEDURES AND REQUIREMENTS**

Most development projects require approvals from the Planning Department or Planning Commission prior to final design of the project. Therefore, it is recommended that developers schedule a pre-application meeting with the Planning Department prior to commencing work on the engineering aspects of the development. The Engineering Division will typically attend these meetings.

Once the initial contact with Planning has occurred, the developer should meet with Engineering to discuss the proposed development and the overall scope of the project. At this time, a project manager from Engineering will be assigned to the project to provide engineering assistance to facilitate the process and to assure compliance with the engineering standards for the City.

The developer is responsible to hire a professional engineer registered in the state of Minnesota to perform the required professional services, which may include, but are not limited to topographic survey, grading, drainage, street, utility plans, easement or vacation documents, and any necessary permit submittals.

#### **A. Memorandum of Understanding (MOU)**

A Memorandum of Understanding will be required for most projects developed within the City of Duluth, and in particular where the intention of the developer is to turn over ownership, maintenance, and operation of the public improvements to the City; when stormwater treatment units are constructed and whenever public improvements or other conditions of approval are necessary. The MOU generally documents the following:

- Specific understandings of both parties relative to the construction of public and private improvements associated with the project,
- Specific project guidance and requirements,
- Which elements of the project will be private and which will be public,
- Which elements of the project will be paid for by the Developer, and
- Amount of deposit to be held by the City until project certification and acceptance.

The MOU template is included in Appendix A.

No construction may begin on a project until the MOU is signed by all parties. The MOU is typically signed in conjunction with final plan approval.

#### **B. Paying for Public Improvements**

Two options are available to allow a developer to have local improvements made and paid for in the City of Duluth:

“Public Improvements Made Privately” where the developer is the responsible party to design, construct, and pay for the desired public improvement, and

“Special Assessments” where the developer chooses to construct the desired public improvements that are paid for either in part or in whole through an assessment against the benefiting property owner(s).

##### **1. Public Improvements Made Privately**

The following procedure applies when the developer chooses to construct a public improvement that will be designed, constructed, and paid for privately. This process, as a general rule, is less costly and quicker to implement than the special assessment process.



Prior to construction:

- a. The consulting engineer determines what the current standards are for the type of improvements contemplated.
- b. The consulting engineer in consultation with the developer prepares preliminary plans for the improvements in accordance with the applicable standards.
- c. The consulting engineer reviews preliminary plans with Engineering and other required City offices.
- d. The consulting engineer reviews the Stormwater Pre-submittal Requirement Worksheet with Engineering.
- e. The developer secures all permits required from other permitting agencies and provides copies of required permits to the City Engineer, prior to City approval for work in County and State right-of-way.
- f. Following approval by the City, the consulting engineer submits plans to other permitting agencies (WLSSD, MPCA, etc.), as required.
- g. The City prepares a MOU between the City and the developer. The MOU will require the developer to deposit funds for City expenses, including project reviews, inspection, surveying, recording fees and approval by Engineering, as required. The consulting engineer shall furnish exhibits for the MOU as required. The consulting engineer shall be required to sign the MOU.
- h. All necessary easements must be legally described in recordable form approved by the City Attorney. Developer must establish to the satisfaction of the City Attorney that they will be able to legally dedicate the easements without cost and absolutely to the City. All final easements must be signed by the developer prior to the start of any construction. The City will not accept the project until easements are accepted by City Council and recorded. All costs to obtain easements or right-of-way, draft the documents, and recording fees are the responsibility of the developer. All easements are granted to the City.
- i. The developer must provide documentation if additional owners of adjacent property/properties are participating in the project cost. This will assure that these property owners will not be charged fees in lieu of assessments in the future.
- j. The consulting engineer submits final plans and specifications to Engineering for review and approval. All plans and specifications shall be signed by a professional engineer registered in the state of Minnesota.
- k. The developer hires a contractor to construct improvements per approved plan.
- l. For all projects where the costs of public improvements are greater than \$150,000, the contractor must have a performance bond and certificate of insurance approved by the City Attorney on file in the Purchasing Office. The City shall be as additional insured on the insurance policy and dual obligee on bond. (Note that all projects within a City street right-of-way require a bond on file with City Engineering regardless of the value of the project.)
- m. The developer and contractor both sign the Application to Make Public Improvements Privately for any new City Streets. A copy of this is included in Appendix B.
- n. The developer hires a consulting engineer or agrees to reimburse the City to provide construction inspection, at the discretion of the City Engineer. City

inspection costs shall be reimbursed by the developer including City audited overhead and direct expenses.

- o. The consulting engineer shall provide notification of project scope, timeline, and emergency contact information to appropriate residents and City Council members prior to the start of construction.
- p. Construction may begin.

#### During Construction:

- a. Inspection is required for all work to be publicly owned, including underground utilities, stormwater treatment facilities, streets, sidewalks, and restoration. In addition, privately owned stormwater facilities shall be inspected by the consultant.
- b. Changes to approved plans must be approved by the City Engineer prior to construction.
- c. Coordinate water main bacteria and pressure testing with the City 48 hours (2 working days) prior to scheduled test.
- d. Coordinate sanitary sewer televising with the City at least one week in advance.
- e. Obtain and compile record drawing information and coordinate data and complete utility forms.

#### After Construction:

- a. The consulting engineer completes all post-construction submittals (record drawings, etc.).
- b. Warranty, final inspections, and acceptance of the project by the City Engineer or designee.
- c. Certification of acceptance of project submitted to City Council by City Engineer.
- d. The City assumes ownership of specified improvements and begins locating of City-owned utilities in accordance with the requirements of the Gopher State One Call System and snow removal for new City streets.
- e. Individual service permits may be issued.

## 2. Special Assessments

When the developer chooses to construct public improvements that are paid for either in part or in whole through an assessment against the benefited property, the developer has several options along with certain responsibilities.

The developer will be required to submit a deposit for 20% of the estimated cost of designing and constructing the planned improvements before construction is started.

One of the first decisions the developer will need to make is whether to have the Engineering Division perform the engineering design and inspection services for the project, or to hire a consulting engineer to perform the design. In either case, the engineering costs are not considered part of the 20% deposit that is required of the developer.

If the property to be assessed is solely owned by a single party, the developer may opt to enter into an agreement approved by the City Council to waive all rights to a public hearing and withdrawal of petition. This would allow the assessment process to proceed more quickly. If the developer doesn't own the requisite property and cannot secure the consent of all affected property owners, he or she will have to follow the assessment procedures set out in the City Charter.

If the developer chooses to hire a consulting engineer to perform the engineering services, such consultant shall prepare the cost estimates necessary for the development assessment application and City Council resolutions.

In addition, if the project involves other property owners, informational meetings with the residents will be required.

Additional information on the special assessment policy related to development and the development assessment application can be found in Appendix C.

### **III. GENERAL ENGINEERING REQUIREMENTS**

Listed below are the general requirements to ensure plan development, project construction, surveys, and record drawings are in accordance with the City's engineering standards, regulations, and policies. The requirements of this document shall be considered the minimum. Specific projects may have additional requirements that may be more stringent.

- a. The most recent version of the *City of Duluth Standard Construction Specifications* and any supplements, addenda, and special provisions shall apply to all work.
- b. The developer will be required to upgrade any existing infrastructure with insufficient capacity to serve the proposed development.
- c. Construction shall not begin on a project until all engineering requirements for public improvements have been satisfied.
- d. For all projects, WPA soil boring maps and sewer plats (on file in the Engineering Division) shall also be reviewed by the engineer to determine approximate rock profiles.
- e. All existing turfed areas within an existing right-of-way that are disturbed shall be restored with sod to a condition equal to or better than the existing condition prior to construction.
- f. All projects with land disturbance greater than 3,000 square feet require a City Erosion and Sediment Control Permit. For land disturbance greater than 1 acre, an MPCA NPDES Construction Activity Permit AND a City Erosion and Sediment Control Permit shall be obtained.
- g. The Contractor and/or the Developer must obtain permission from City Engineering and obtain permits for any and all road closures, detours, and haul routes.
- h. Engineering drawings shall not utilize color, except for photographic imagery.

#### IV. TRANSPORTATION REQUIREMENTS

The Engineering Division is responsible for all street and roadway related projects within the public right-of-way, including the inspection, construction, and replacement of streets, alleys, bridges, sidewalks, and traffic signals, as well as addressing traffic concerns.

The following general transportation requirements will be required for most projects developed within the City of Duluth:

- a. A traffic study may be required if Engineering determines there may be an adverse impact on traffic, mobility, and/or safety due to the proposed development.
- b. Soil borings shall be completed prior to the design of any street project. The borings shall be evaluated by a registered engineer and recommendations made in writing. Borings shall be located within the project area at intervals necessary to accurately assess the soil conditions within the project area. Boring information shall be included on the drawings. A copy of the boring information and geotechnical report signed by a licensed engineer shall be submitted to Engineering.
- c. Follow the local Street Design Standards.

##### A. Local Street Design Standards

The minimum standard cross-section for the construction or reconstruction of a local street shall conform to the table listed below:

Dimension Requirements – Local Streets			
	Street Width Curb-Face to Curb-Face	Boulevard Width	Sidewalk Width
New	28' (24' with no parking)	Minimum 8'	5'
Reconstructed	24' – 28'	4' – 8'	5'
Historic Designation	per guidelines below		

The Dimension Requirements listed above also establish the requirements for extending an existing street for the purposes of accessing a proposed development. In many cases, the existing street does not meet the current Local Street Design Standards or the Typical Section Standards. However, the extended portion of new street frontage shall be constructed with curb and gutter to the standards shown. Deviation requests must be approved by the City Engineer. Such requests will not consider financial hardship.

In general, the costs to improve, reconstruct, or construct the existing street to the City of Duluth's minimum standards shall be born 100% by the developer.

Note that in all cases, the requirements represented are minimums, and in no case shall the extended street be constructed to a standard less than the existing street. Further, it is the responsibility of the designer to incorporate the requirements of the most current fire code observed by the Duluth Fire Department.

In addition, it is recognized that under unique circumstances where an existing street is not constructed, reconstructed, or improved to City of Duluth standards for an urban bituminous street, there may be a need for a recordable "disclaimer" agreement between the City and the developer so as to provide for the assessment of future street improvements against adjacent properties per the City's code provisions regarding "Local Improvements" (Article VII, as amended by Ordinance 09-019-0).

### 1. Boulevards

Boulevards shall be provided on both sides of a street and shall be planted with trees in accordance with the UDC and the Engineering Department's Construction Standards.

### 2. Sidewalks

Each proposed public or private street within the R-1, R-2, R-P, MU-P, MU-N, MU-C, MU-I or MUW districts shall include a sidewalk at least five feet wide on both sides of the street. Each proposed public or private street within the MU-B, I-G or I-W districts shall include a sidewalk at least five feet wide on one side of the street.

Requests to waive the sidewalk requirements shall be directed to the City Engineer and will only be considered when based upon public safety or due to site/topography constraints.

### 3. Reconstructed Streets

Under certain circumstances and through granting of variances (as described below), reconstructed streets may be less than 24 feet, but in no case shall they be less than 20 feet wide. At least one of the following criteria must be met to grant such a variance:

- a. Where adjacent collector streets are aligned in a way that encourages traffic to short-cut through a neighborhood, narrower streets, along with other measures to discourage such short-cutting are justified; or
- b. The presence of alleys or other off-street parking opportunities which eliminate the occurrence of on-street parking by residents justifies narrower streets; or
- c. Low residential densities (wide single-family lots) which eliminate the need for on-street parking may allow for narrower street than standard; or
- d. Mature trees within the right-of-way, which would otherwise be able to be retained, justifies narrower streets; or
- e. Where the character of the immediate neighborhood would otherwise be negatively affected (i.e., scale of street relative to adjacent buildings, grades

- requiring new retaining walls which would be out of character with the existing architecture, wide street distracting from important views of residences, loss of privacy screening, degradation of gardens, etc.) a narrower street is justified; or
- f. Where there would be insufficient space for snow storage because the wider street would result in more plowed snow to be stored and thus higher snow banks which would cause visibility problems.

#### 4. Historic Designation

A 20-foot wide variance would typically be allowed on an existing 20-foot-or-less street if at least two of the following criteria are met:

- a. The street is located within a locally designated or a proposed designated historic or conservation district. (Survey in place or underway determining historic designation or significance.)
- b. If and only if the street has historically always been 20-foot-or-less in width.
- c. At least one locally designated historic landmark or national register home or property is located on the street.
- d. An historic street material or feature is present (which should be respected, i.e., trees, landscape features, granitoid, street lighting, signage, retaining walls, fencing, monuments, curbing, etc.). The “new” street material should reflect sensitivity to these materials.
- e. A ruling body which deals directly with Duluth’s heritage or Duluth’s historical structures and areas (such as the Heritage Preservation Commission) has determined that the historic character of the immediate neighborhood would be affected by widening the street to more than a 20-foot width.
- f. In situations in which, due to extreme topographical limitations, a street width variance would allow a lower cost or more reasonable alternative in the construction or reconstruction of the street.

#### **B. Shared Use Path/Trail Section Requirements**

When a Shared Use Path or Recreational Trail is required by the UDC or Planning requirements as a condition of development, design and construction within the development or within City easements/right-of-way shall comply with MNDOT’s most current edition of the Bicycle Facility Design Manual. For Shared Use Path or Recreational Trails located within roads designated as State Aid Routes, the design and construction shall comply with MS 8820.9995 “Minimum Off-Road and Shared Use Path Standards”. An example typical section can be found in Appendix D.

#### **C. Typical Section Standards**

Unless a different section is approved as noted above, all new roads in the City of Duluth will be built to urban design standards.

The standard specification for a local road section is outlined in the table below and the example CAD drawing of the typical section can be found in Appendix D.

City of Duluth Standard (Minimum)	Urban Bituminous
Geotextile Fabric	Type 5 (non-woven)
Select Granular Backfill (mod <7%)	12"
Class 5 Aggregate Base	8-1/2"
Width of Street	28' (24' with no parking)
Drainage	as per City Engineer
Surfacing Material	Bituminous
Depth of Surface Material	3-1/2"
Width of Surfacing	28' (24' with no parking)
Concrete Curb & Gutter (B624)	Yes

#### D. Driveways and Alleys

All driveways and alleys shall be installed in accordance with the City of Duluth Driveway Entrance Requirements contained in Appendix E, and to the typical sections shown in Appendix D, and as per the Policy on the Issuance of Driveway Permits for Private Improvements in Right-of-Way, found in Appendix F.

#### V. UTILITIES REQUIREMENTS

The Engineering Division is responsible for ensuring all utility projects, including the design, inspection, installation, and replacement of gas, water, sanitary sewer, and stormwater improvements comply with state and federal regulations.

- a. All underground utilities to be publicly owned shall be installed in the existing or proposed public right-of-way when feasible. Where, due to topography, installation within the right-of-way is not possible, the City may accept underground utilities installed in a utility easement on a case-by-case basis.
- b. All utilities that will be privately owned and maintained shall not be installed within public right-of-way.
- c. Water, sanitary sewer, and storm sewer laterals must be installed perpendicular to the street right-of-way and include a tracer wire locating box at the edge of the right-of-way per the *City of Duluth Standard Construction Specifications*. Private laterals shall not be installed within and parallel to the right-of-way.
- d. Publicly owned utilities less than 10 feet deep installed outside the City right-of-way will require a minimum of a 20-foot wide permanent easement; utilities deeper than 10 feet shall have 30-foot wide easement. The utility must be centered within the easement, and the easement shall be dedicated to the City and recorded with St. Louis County prior to starting construction.
- e. Public utilities not located within City right-of-way must be located in an easement where City maintenance crews have clear access to inspect and maintain the utility. All sanitary and storm sewer manholes must be accessible

by City sewer cleaning equipment. This includes providing a driving surface if necessary to support this equipment.

- f. Where public utilities are installed on private property, the property owner shall be responsible for all future surface restoration required due to repair or maintenance of the utility by City crews.
- g. Infrastructure extensions not constructed and installed to City standards shall be corrected prior to City acceptance and prior to being placed into service. If defects are not corrected, the utility shall not be placed into service. Where, for any reason, the defective utility has been placed into service, the developer shall be responsible for ownership and maintenance of the utility until the defects are corrected.
- h. Installation of all utilities shall extend entirely across the frontage of the lots to be served, unless otherwise approved by the City Engineer. If the project is completed in stages, then all utilities must be extended past the lot line of the last house served and beyond the pavement limits.
- i. Where a property to be developed is not currently served by water and sewer, the developer shall be responsible for all costs to extend the utilities to the property.
- j. Where an undeveloped parcel is served by existing water and sanitary sewer, fee in lieu of assessments may be due to the City prior to connection to the utilities.

#### **A. Natural Gas**

All extensions to the City of Duluth natural gas distribution system and services shall be designed and constructed in accordance with the *City of Duluth Public Works and Utilities Department Gas Operation and Maintenance Manual*, along with the *City of Duluth Standard Construction Specifications*, including any supplements, addenda, and special provisions.

- a. The City no longer provides any underground natural gas pipe free of charge. The developer shall pay for all gas mains and services installed or pay the two-tier rate where eligible.
- b. Any project with a natural gas component shall be reviewed by Engineering. All construction inspection of natural gas mains shall be performed by City staff. Any gas main installed without inspection will be required to be removed.
- c. Natural gas mains in new developments shall not be installed until after curb and gutter for the street is placed.
- d. All new services require a service application to be submitted to the Engineering Division prior to September 1 for installation that year.
- e. Natural gas installers must be certified per the City standards.
- f. For installation of pipes on new building sites, the site must be prepared (graded within 2" of final elevation) for installation no later than November 1 of each construction year.
- g. After November 1, an approved trench must be excavated by the developer to enable installation of the line to occur prior to the following construction season. Trench details can be found in the most recent edition of the *City of Duluth Standard Construction Specifications*.



## B. Water

All water mains shall be installed in accordance with the *Recommended Standards for Water Works* by the Great Lakes Upper Mississippi River Board of State Public Health and Environmental Managers (Ten-State Standards) except as stated below or as listed in the *City of Duluth Standard Construction Specifications* and any supplements, addenda, or special provisions.

- a. Minimum water main diameter shall be 8 inches unless approved otherwise by the City Engineer.
- b. The City may require upsizing of proposed water mains for future projects.
- c. The City may require upsizing of existing mains, pressure reducing stations, or booster stations to provide adequate flows to the proposed development area.
- d. In general, water main extensions shall be publicly owned. The developer may request a water main to be privately owned if the main and the services are not located within the City right-of-way and where it will not serve any future development. Privately owned mains also require permitting from the Construction Services & Inspections Division as plumbing.
- e. The City will determine, on a case-by-case basis, if water booster stations or water pressure reducing stations required for the project will be owned by the developer or by the City. All booster stations or pressure reducing stations to be owned by the City shall be designed and constructed to City standards. In all cases, the developer shall pay for installation of telemetry equipment for remote monitoring of the equipment by the City. Privately owned booster stations also require permitting from the Construction Services & Inspections Division and a Homeowners' Agreement recorded against each applicable lot.
- f. Inspection of high-density polyethylene (HDPE) pipe must be performed by an inspector qualified by the City of Duluth.
- g. Minimum fire flows for main extensions shall be in accordance with the City of Duluth Fire Department requirements.
- h. Water main valves shall be spaced from 300 to 400 feet apart or at the end of every city block or as specified by the City Engineer.
- i. Hydrant locations shall be spaced from 300 to 400 feet apart or at the end of every city block or as specified by the City of Duluth Fire Department. A hydrant shall be provided at the end of all dead-end mains unless a blow off is approved by the City Engineer for mains smaller than 6 inches.
- j. Minimum cover on all water mains (HDPE and ductile iron) shall be 7'-6". Except dead end mains shall have a minimum of 8'-0" of cover. Maximum cover of any main shall be 9'-0" without special approval from the Chief Engineer of Utilities.
- k. Water main extensions shall be HDPE unless specified otherwise by the City Engineer.
- l. Water services may be copper or HDPE. Minimum size for copper water services shall be ¾-inch. Minimum size for HDPE water services shall be 1-inch, SDR 9.

- m. The use of electro-fusion couplings shall be minimized and the location of any electro-fusion couplings shall be documented on the record drawings.
- n. All existing valves and hydrants shall be operated only by City personnel except where approved by the City Engineer or the Utility Operations Supervisor.
- o. Coordinate water main bacteria and pressure testing with the City 48 hours (2 working days) prior to scheduled test. Contact the Water Plant at 218-730-4160 to request a sample be collected. All pressure tests must be witnessed by the City. All bacteria samples will be collected and tested by the City.

### **C. Wastewater Collection System**

All sanitary sewers shall be installed in accordance with the *Recommended Standards for Wastewater Facilities* by the Great Lakes Upper Mississippi River Board of State Public Health and Environmental Managers (Ten-State Standards) except as stated below or as listed in the *City of Duluth Standard Construction Specifications* and any supplements, addenda or special provisions.

- a. All wastewater lift stations to be owned by the City shall be designed and constructed to City standards. The developer shall pay for installation of the station, including telemetry equipment (SCADA) for remote monitoring of the equipment by the City for both public and private (where applicable) owned stations.
- b. The City may require upsizing of existing and proposed sewer mains and lift stations to provide adequate capacity to the development area or future projects.
- c. In general, future sanitary sewer main extensions shall be publicly owned. The developer may request that a sanitary sewer main be privately owned if it is not located within the City right-of-way and where it will not serve any future development. Privately owned sanitary sewer mains also require permitting from the Construction Services & Inspections Division and a Homeowners' Agreement recorded against each applicable lot.
- d. Minimum cover on sanitary sewers shall be six feet. Maximum cover on sanitary sewers shall be 15 feet without prior approval of the City Engineer.
- e. Minimum slope on all publicly owned 8-inch sanitary sewer mains shall be 0.5%.
- f. All drop manholes for 8-inch mains shall be inside drops as shown in the *City of Duluth Standard Construction Specifications*. For mains larger than 8-inch diameter, the design engineer shall recommend a drop structure for review by the City Engineer.
- g. All dead-end sanitary mains shall have a manhole at the end.
- h. Sanitary or storm manholes shall not have steps.
- i. Manholes for new construction shall have a minimum drop of 0.10 feet from the upstream invert to the downstream invert.
- j. All new sanitary sewers will be inspected by the City with closed-circuit television. Coordinate sanitary sewer televising at least one week in advance. The engineer shall coordinate this by contacting Utility Operations at 218-730-4130. All other testing shall be witnessed and certified by the engineer. The cost incurred by the City for televising will be deducted from the MOU deposit paid by the developer or directly invoiced.

- k. Any time a sanitary sewer lateral is excavated for any reason, the entire lateral must be capable of passing an air test prior to backfill. For project sites being redeveloped, only PVC laterals may be reused. All other laterals must be replaced.

### Sanitary Sewer Extension Permits

All projects that add a substantial increase in wastewater flow to the City of Duluth wastewater collection system shall be required to obtain a MPCA Sanitary Sewer Extension Permit prior to construction. Projects that add substantial flow but do not construct new sanitary sewer mains may still require permitting. All permit questions shall be directed to the Chief Engineer of Utilities.

Sanitary sewer extension permits should be completed and forwarded to the Engineering Division along with WLSSD permit information. WLSSD forms are available on their website at [www.wlssd.com](http://www.wlssd.com). Following review and approval by the City, signed forms shall be collected by the developer and forwarded to WLSSD along with the appropriate payment.

### **D. Stormwater**

The Community Drainage System – CDS, serves the area in and around the City and is comprised of pipes/tunnels/culverts, catch basin/manhole structures, and natural/constructed ditches and drainage ways that function as a system to capture and convey surface water through the community. The system is owned and maintained by a variety of parties that include the City, MNDOT, County, or other public agencies and/or private property owners that include commercial, industrial, housing developments, and private homeowners.

This system moves precipitation from rain and snowmelt and surface water from streams and creeks through the City to Lake Superior. The City wants to ensure that improvements, additions, repairs, and replacements to the community drainage system are not detrimental to the system, and it continues to work as an interconnected system to minimize flooding and conveying stormwater from the community, while at the same time ensuring that the quality of the water discharged to the creeks, streams, and lakes is not diminished. The Federal Clean Water Act requires the City to meet the requirements of the MPCA MS4 stormwater permit program and demonstrate that the City takes responsibility for preventing pollution from entering our natural waterways.

All questions regarding stormwater management shall be addressed to Tom Johnson, Senior Engineer - Stormwater, at [tajohnson@duluthmn.gov](mailto:tajohnson@duluthmn.gov).

When developing a project in the City of Duluth, the following stormwater policies, permits, and codes shall be followed, and the most stringent requirements shall govern:

- a. The requirement found in this document – Engineering Guidelines.

- b. City's Standard Construction Specifications (public improvements). [Standard Construction Specifications \(duluthmn.gov\)](#)
- c. Construction Services & Inspections Division – plumbing code for private storm sewer design and permit. This does not take the place of the Engineering review and approval for overall drainage compliance.
- d. City of Duluth Unified Development Code. See City webpage for current revision. <https://duluthmn.gov/planning-development/land-use-zoning-and-applications/zoning-regulations/>
- e. The General Municipal NPDES Separate Storm Sewer System (MS4) Stormwater Permit; <https://www.pca.state.mn.us/sites/default/files/wq-strm4-94.pdf>
- f. MPCA General Permit Authorization to Discharge Stormwater Associated with Construction Activity under the NPDES. <https://www.pca.state.mn.us/sites/default/files/wq-strm2-80a.pdf>
- g. MPCA NPDES Multi-Sector General Permit for Stormwater Discharges Associated with Industrial Activity Additional information regarding the MPCA permit programs can be found at [2020 Industrial Stormwater General Permit \(MNR050000\) \(state.mn.us\)](#)
- h. Public Works & Utilities is the City department that is responsible for utility billing. Stormwater is billed as a utility fee, and for all non-residential properties the fee is based on the actual impervious surface area serving the development. The developer/owner should be made aware of this monthly fee, and that credit is given for the installation of and properly maintained structural stormwater management BMPs. BMPs are required by code for the project, and additional or retrofitted BMPs are encouraged to be added to sites as appropriate and will receive additional credit as applicable. Residential housing projects (multi-family structures) are billed by total number of dwelling units, with credit granted for multi-family structures, though no credit is given for BMPs that are required per the UDC. The drainage report shall model the pre-settlement discharge rates in determining fee credit allocation for BMPs.

#### Plumbing Code Review Construction Services & Inspections Division versus Engineering Division Review.

The City policy for review, approval, and permitting will be as follows (from the Construction Services & Inspections Division's Policy and Procedure Manual, item No. 4.14, Building storm drain point of disposal, revised 10/15/2014):

*The point of disposal will be an engineered storm water treatment or collection system or the connection point to the public storm sewer system or natural drainage course. Plumbing permits will be issued for the work to the point of disposal and design and installation shall follow the requirements of the Minnesota State Plumbing Code.*

*The transition from plumbing to the engineered storm water treatment or collection system shall take place at the point of disposal which may be located within the 10 foot limitation listed in MSPC Sec. 4715.2820, Subp. 2. The testing requirement in this*

*section only apply to the building storm drain piping, not the engineered storm water treatment or collection system. The plans shall clearly delineate this transition location. Where new storm sewer will be owned by the City (via easement or within R.O.W.), the plans shall clearly delineate the limits of public versus private ownership.*

### Unified Development Code (UDC)

The City of Duluth UDC includes specific requirements for both temporary and permanent erosion control and water quality requirements and discharge rate, volume, and temperature controls. The design engineer shall review the code to determine the specific requirements for each project. In addition to the requirements listed in the UDC, there are additional requirements are included within this section. The UDC shall be reviewed for other rules that may affect proposed projects in shoreland zones, mapped floodplains and sites with wetlands, all of which potentially affect the stormwater management requirements for the development site.

### MPCA MS4 Permit Summary/Requirements/Guidance

The City of Duluth is an MPCA designated Municipal Separate Stormwater System (MS4) NPDES Permit holder with a special “selected-Non-Degradation” status that results in stringent requirements for stormwater discharge. Additionally, Lake Superior is a MPCA designated Outstanding Resource Value Water (ORVW), 16 trout streams within the City boundaries and the St. Louis River designated as an Area of Concern (AOC), which requires additional stormwater discharge restrictions. Duluth is required to minimize impervious surface so as to reduce the total runoff volume load of stormwater to the level that occurred prior to 1988. Duluth must also have specific methods to eliminate new and expanded (stormwater) discharges.

The current City of Duluth MS4 permit states that no "new or expanded" stormwater discharge to Lake Superior should occur. This implies that all stormwater runoff from newly installed impervious surfaces shall be fully contained on site and infiltrated whenever possible. When this is not possible, the developer must restrict discharges to the maximum extent possible (MEP). During site planning, preliminary design and final design, the developer shall document in the drainage report what actions were taken to avoid, minimize, and mitigate the volume of stormwater discharged to the MEP level. Utilization of Low Impact Development methods shall be evaluated for all projects. The MPCA reserves the right to make the final determination of all prudent and feasible alternatives and determine whether the methods proposed are significant enough to preserve the high quality of the ORVW.

The pollutants specifically identified in the MS4 permit are total stormwater Volume (TVOL), total suspended solids (TSS), total phosphorus (TP), and temperature (T). Proposed Projects must go through certain steps, beginning with initial planning, and use the most aggressive standards feasible to restrict pollutant discharge. Methods to restrict discharge include site planning to reduce the impervious footprint, utilizing Low Impact Development (LID) methods, designation of buffer areas/green spaces, and

other methods and design approaches found in the Minnesota Stormwater Manual and other publications. Any and all projects that propose fully reconstructed impervious surfaces will provide treatment for a water quality volume to be determined.

Duluth has many impaired public waters with numerous MPCA TMDLs, this requires the proposed project to determine if there are additional requirements needed for the stormwater management plan.

### MPCA Construction Stormwater General Permit

If the project creates an acre or more of land disturbance, the project shall obtain a MPCA CSW permit and shall meet the requirements of this permit in addition to the City requirements.

### MPCA Industrial Stormwater Permit

If the project is within a facility that conducts industrial activities as identified by the MPCA under the MPCA NPDES Multi-Sector General Permit for Stormwater Discharges Associated with Industrial Activity, the industrial stormwater management plan (SWPPP) shall be submitted as part of the drainage report.

### Stormwater Management Plans – Process

The following are the major steps in the process for getting approval of the stormwater management system for a project. Additional requirements for the steps listed are discussed later in this document. A permit fee schedule can be requested from the engineering department related to the items below.

1. Preliminary Design Submittal and Meeting: Stormwater management requirements for development and redevelopment projects must be reviewed in the early phases of design. A preliminary design submittal worksheet shall be completed and a meeting with the stormwater engineer to discuss the project.
2. Drainage Report: A final drainage report with the proper format and content is required for all projects, and shall be submitted with the building permit application. This can be submitted to the stormwater engineer prior to the permit submittal to ensure timely review, revisions, and final approval.
3. Erosion Control Plan: Projects shall complete a City Erosion and Sediment Control Permit per the UDC. A complete temporary stormwater management plan (SWPPP) shall be submitted to and approved by the stormwater project engineer. All sites will be inspected by the City and MPCA. A SWPPP and erosion control permit will need to be completed as part of the permit package.
4. MS4 Statement of Compliance (MS4 SOC): Upon approval of the temporary and permanent stormwater management plans (Drainage Report), a MS4 Statement of Compliance shall be drafted by the stormwater engineer specific to the project, signed by the project's civil engineer and the owner. This will need to be completed prior to the issuance of any building permit(s).

5. Record Drawings: The design engineer shall provide record drawings of the constructed stormwater management system and provide a statement that the system was constructed to the project construction plan and specifications. See this document for submittal requirements for as-built/record drawings, for both public and private. **The Certificate of Occupancy will not be issued until the record drawings have been submitted and approved.**
6. Stormwater Management Facilities Operation and Maintenance Manual: A separate document to be submitted post-construction to the owner and the City.
7. Memorandum of Understanding: All projects constructing publicly owned stormwater facilities and/or privately-owned BMP's will require a Memorandum of Understanding and a deposit from the developer. A full refund of the deposit will be issued when all requirements have been met.

### Stormwater Management Design Approach

The UDC (Section 50-18) regulates the stormwater runoff from a development for the following discharge parameters: 1) discharge rate / flood control (Q), 2) runoff volume (TVOL), 3) total suspended solids (TSS), 4) total phosphorus (TP), and 5) temperature (T), 6) floatables – trash, debris, oils/grease and total petroleum hydrocarbons. The maximum allowable discharge levels for these parameters will be determined by the combination of the pre-project site conditions and the proposed development. When the proposed development is a mix of redeveloping existing impervious area and adding new impervious area, the above parameters shall be weighted from the existing predevelopment/project site conditions to determine the allowable levels of discharge parameters leaving the proposed project site based on the UDC requirements. This shall be discussed at the preliminary design submittal meeting.

Typically, development projects alter the drainage of a site due to altering the existing drainage patterns and from the improvements made (buildings, parking lots, pavement, etc.), and creating the need to collect, convey, and treat/attenuate the stormwater runoff. The discharge of runoff from a proposed development shall not cause negative impacts or increase flooding risk to down gradient property owners, public infrastructure, and natural drainage ways and creeks.

Stormwater management is a comprehensive system consisting of various BMPs to meet the requirements set forth in the UDC and this document. A development shall not only look at the specific project site but rather the larger context of the surrounding area and the project's impact on down gradient property, infrastructure, and natural waterways and creeks and Lake Superior. A development should look at incorporating measures to retrofit existing stormwater infrastructure as redevelopment opportunities arise with BMPs that provide stormwater management controls.

Wetlands located on the development site shall be avoid and/or impact to them minimized. If the project impacts wetlands, the loss of wetlands can negatively alter groundwater recharge and increase site's peak discharge rates and volume in the post construction condition. The stormwater management system will need to provide for

this loss and incorporate it into the permanent stormwater management system. Wetlands that are located in topographic depressions shall have a volume of natural storage determined and will be added into the final BMP sizing calculations. Preservation of wetlands is encouraged along with the hydrology that flows to them. Wetlands shall be discussed during the preliminary site design meeting.

Projects located within trout stream watersheds play a critical role in the long-term health and viability of the stream. These projects need to be successful in managing stormwater and not create additional impairments to these sensitive streams.

Water Quality Controls: Water quality controls are required to remove sediment, phosphorus, and debris from stormwater runoff from improved property. The discharge of sediment into the community drainage system negatively impacts our natural drainage ways and creeks, requires maintenance on culverts/ditches and storm pipes, and increases the potential for flooding due to reduced conveyance capacities. Phosphorus discharged in stormwater runoff negatively affects water quality by creating algae blooms, depleting dissolved oxygen levels, creating unpleasant odors, and degrading fish and wildlife habitat. Urban runoff contains floatables such as trash, debris, needles, oils, and other hydrocarbons that get washed off streets, driveways, and parking lots into the storm sewer system and ultimately into Lake Superior.

Methods of water quality controls may include infiltration/bio-filtration basins, wet sedimentation ponds with forebays, sedimentation traps/cambers as part of a treatment train, bio-swales, water quality structure (swirl chambers, sump manholes with floatable traps/energy dissipation, etc.). Low Impact Development design methods and other demonstrable methods are viable options. All projects shall have water quality BMPs that capture floatable debris and sediment from the project site's runoff.

*Per MS4 Permit MNR040000 – 20.7 For linear projects, the water quality volume must be calculated as the larger of one (1) inch times the new impervious surface or one-half (0.5) inch times the sum of the new and the fully reconstructed impervious surface. Where the entire water quality volume cannot be treated within the existing right-of-way, a reasonable attempt to obtain additional right-of-way, easement, or other permission to treat the stormwater during the project planning process must be made. Volume reduction practices must be considered first, as described in item 20.8. Volume reduction practices are not required if the practices cannot be provided cost effectively. If additional right-of-way, easements, or other permission cannot be obtained, owners of construction activity must maximize the treatment of the water quality volume prior to discharge from the MS4.*

Runoff Rate Control: Runoff rate control is more critical and achievable in the upper, flatter part of the watershed above the escarpment. Below the escarpment, or bluff line, the topography is relatively steep and stormwater flows quickly to Lake Superior and the St. Louis River. This bluff line designation is shown on the NRO Map. The stormwater rate control requirements for development and redevelopment are shown in the UDC Table 50.18.10E-4. Changes to the runoff discharge location from the existing



conditions will require analysis to verify that there are no negative impacts to down gradient properties or infrastructure.

Methods of runoff rate control may include; stormwater detention ponds, infiltration and bio-filtration basins with engineered freeboard, below grade storage systems, engineered swales, and other demonstrable methods. All rate control BMPs shall have outlet control structures that minimize maintenance and are easily accessible for inspections. Hydraulic modeling of the outlet structure shall be performed for each of the required designed storm events.

Stormwater BMPs designed for rate/flood control shall not be used for snow storage from snow removal operations for the developed site. This reduces the capacity of the basin during spring melts and early season rainfall events. Public ROWs, ditches, stream channels are also not allowed for snow storage.

Runoff Volume Control: Volume control's goal is to minimize the volume of stormwater runoff from a site by matching the existing runoff characteristics of a site and thereby reducing volume and pollutants leaving a site and promoting ground water recharge. Volume control is challenging in the City of Duluth due to grades, soil type, and shallow groundwater and bedrock. A geotechnical soil investigation is required for a proposed project site to determine the viability of volume control BMPs. Field investigation shall be conducted at all location(s) where BMPs may be potentially installed as well as alternative locations, to ensure all options are reviewed to meet the UDC standards.

Methods of volume control include infiltration into the ground, which is the preferred method where feasible and bio-filtration with elevated subdrains is the most viable option with cohesive soils. The following options can provide minor volume reduction only during the growing season: evapotranspiration, storage/harvesting for reuse, green roofs, conservation designs, engineered/enhanced swales and filter strips, disconnection of impervious surfaces, and other demonstrable methods of volume reduction.

All proposed pervious areas that are disturbed during construction shall include soil ripping/tilling/loosening prior to restoration to reverse soil compaction that occurs during construction activities.

If volume controls are technically non-feasible, increased rate control / attenuation and water quality measures beyond the UDC standards are potential options to explore and shall be discussed at the preliminary design submittal meeting.

Infiltration practices are not applicable for sites with vehicle fueling and maintenance areas, contaminated soils, insufficient separation to saturated soils or bedrock, type D soils, and certain industrial activities. The See MPCA NPDES/SDS Permit NoMNR040000.

Runoff Temperature Controls: If the project location discharges to a cold water trout stream watershed, as identified in the UDC, MPCA Special Waters search tool and/or

the DNR database (data deli), the project must take measures to minimize the risk of increasing the temperature of the stormwater runoff from the site and negatively impacting the stream habitat.

Methods of reducing runoff temperature include below grade attenuation/storage structures, infiltration, bioretention/filtration (sufficient filtration depth), disconnected impervious surfaces, pervious pavers, green roofs, shading from tree canopies, engineered/enhanced swales and filter strips, and other demonstrable methods of temperature reduction BMPs. These and other methods require proper design to function properly and should be discussed during the preliminary design meeting.

### Design Rainfall Event

Rainfall events or runoff events within the City shall be defined as outlined below (NOAA Atlas 14) to be used for all project location:

- a. The 2-year, NRCS Type II rainfall event is defined as 2.7” of rainfall in 24 hours.
- b. The 10-year, NRCS Type II rainfall event is defined as 4.0” of rainfall over 24 hours.
- c. The 100-year, NRCS Type II rainfall event is defined as 6.4” of rainfall over 24 hours.
- d. The 100-year 10-day snowmelt is defined as 8.1” of runoff (frozen ground conditions).

### Preliminary Design Submittal Worksheet and Meeting

A preliminary design submittal worksheet shall be prepared at the start of all projects during preliminary design and prior to platting. This worksheet is designed to provide initial project information to the City and alert engineers and developers of stormwater requirements prior to the start of the project. A copy of this worksheet is included in Appendix I. The worksheet shall also be included in the drainage report. A meeting with the City Engineer is required as part of the preliminary design, and no drainage report will be reviewed without first conducting this step. Preliminary Design Submittal can be completed via virtual video conferencing with the City Engineer as long as Preliminary Design Submittal Worksheet and exhibits are complete and sent to the City Engineer in advance.

### Drainage Report

The drainage report is the required format for submitting the permanent stormwater management plan and analysis for all projects. Review will not start on partial or incomplete drainage reports. Drainage reports shall be submitted as part of a project plan review and/or building permit submittal. The drainage report shall follow the format and content requirements discussed below.

1. Coversheet for project/development with signature by an engineer registered in the state of Minnesota

2. Drainage Report Submittal Checklist (Appendix H)
3. Table of contents with appendices listed
4. Introduction/Executive Summary
  - a. Describe the hydrologic and hydraulic methods and software used to analyze the site.
  - b. Describe the watershed the project is located in and its characteristics.
  - c. Provide a summary chart of pre and post project surface area types, runoff rates and volumes and the percentage change in each.
  - d. Provide a statement/conclusion on the project's performance in meeting the requirements of the UDC and the Engineering Guidelines.
5. Narrative of the project:
  - a. Describing the type and scope of the project
  - b. Estimated construction start and completion dates
  - c. Project phasing and sequencing of construction activities
  - d. Unique construction activities; rock blasting/removal, stream flow diversion, deep excavation, and/or other construction activities.
6. Pre-Project Conditions
  - a. Discuss size of site, existing impervious areas (size and type), existing pervious areas (size and type of vegetation)
  - b. Discuss existing drainage characteristics, including runoff rates and volumes for each delineated sub-watershed/catchment areas on the project site. Discuss how the drainage is currently routed down gradient from the site onto adjacent properties and its routing to the receiving waters (streams, St Louis River or Lake Superior).
  - c. Exhibits shall include pre-project topographic site maps showing delineated catchment areas with CNs and Tc, comprehensive flow arrows and routing, and surface area types. Plan/detail sheets shall be a 11 x 17 max. folded into and attached to the report.
  - d. The site shall also be modeled for the pre-settlement condition to determine BMP fee credit allocation, as the credit is based on rate reduction of the proposed site improvement compared to a green undeveloped site.
7. Post-Project Conditions
  - a. Discuss post-project impervious and pervious areas (size and type).
  - b. Discuss the post-project drainage characteristics of the site as a result of the project
    - Changes to the catchment areas
    - Discharge rates and volumes
    - Changes to the discharge routing/location(s) and subsequent impacts to down-gradient properties, infrastructure, and receiving waters
    - Capture and conveyance system for stormwater runoff
    - Exhibits shall include post-project topographic site maps showing delineated catchment areas with CNs and Tc, and storm sewer infrastructure. Plan/detail sheets shall be 11 x 17 max. folded into and attached to the report.

- c. Discuss the permanent stormwater management system for the project as a cohesive singular system and its individual components to address the below control requirements.
  - Discuss the project's approach to utilizing Low Impact Design practices in meeting the permanent stormwater management goals.
  - Routing: Discuss the routing of stormwater runoff within the site for the design storms indicated and for larger events during frozen or clogged conditions, i.e. overland flood routing. Discuss the percentage of runoff that is not routed to a BMP.
  - Discharge Rate (Q): Discuss how discharge rate control requirements are met on the project.
  - Volume Control (TVOL): Discuss the runoff volume control measures. What methods are being implemented to meet this requirement. Compare the pre and post-project condition in regard to runoff volume. Provide a soil exploration report with boring logs in the appendix.
  - Water Quality (TSS, TP): Discuss how the water quality controls meet the requirements for total suspended solids and total phosphorus reduction and removal.
  - Temperature (T): Discuss if the project is required to meet this control and if so how is it being met.
  - Exhibits shall include site maps with proposed topography, locations of BMPs, flow arrows showing runoff going to each BMP and offsite, BMP details (cross sections, plan views, outlet details, access, contribution area, bottom elevation, live storage, dead storage, discharge rates for 2-year, 10-year, 100-year events, high water (HW) elevations from each event). Plan/detail sheets shall be 11 x 17 max. folded into and attached to the report. Include design worksheets/modeling printouts/calculations.
8. Storm Water Pollution Prevention Plan (SWPPP) / Erosion and Sediment Control Plan.
  - a. The SWPPP / Erosion and Sediment Control Plan shall be included in the drainage report as an attachment, consisting of the plan sheets that are part of the final plan set.
  - b. A SWPPP is required for all projects as defined in the UDC. The MPCA General Permit Authorization to Discharge Stormwater Associated with Construction Activity under the NPDES shall be reviewed for requirements and incorporated as required.
  - c. All plans shall include but not limited to perimeter/sediment control, inlet protection for all inlets that may potentially receive runoff on the project site or within the ROW, vehicle tracking pad at the site access/exits and mulch/erosion control blankets to provide temporary stabilization as needed.
  - d. The SWPPP is a dynamic document and shall be updated as the project proceeds. As site conditions change and contractor activities occur the SWPPP shall be updated to accurately document the erosion and sediment controls being used and which ones have been added, cleaned, repaired, or

- removed. The requirement to update the SWPPP during construction activities shall be noted in the SWPPP.
- e. If the project scope, phasing or limits change from the approved SWPPP, the permittee shall amend and resubmit the plan for approval by the City Engineer.
9. Stormwater Management Facilities Operation and Maintenance Manual shall be included in the drainage report. A final post-construction O&M manual will be submitted after record drawing information has been obtained and incorporated into the manual. The manual shall include the following content:
- a. A summary of the permanent stormwater management system for the site and clearly describing ownership of the system.
  - b. A site plan showing the drainage patterns of the site, routing of stormwater runoff to the BMPs, and the location where stormwater runoff discharges from the site. Include the access points for inspection of the BMPs.
  - c. A description of the function of the BMPs, for each component and as a system.
  - d. A check lists for annual inspection and maintenance. The check list shall reference the site plan for key inspection points.
  - e. For structures to be owned and maintained by a Homeowners Association, submit a copy of that agreement with sufficient detail clearly delineating between City of Duluth and private ownership. Include Developers Agreement/MOU sections that pertain to storm/surface water.
  - f. This document will be considered preliminary prior to construction, should be included in the drainage report, and shall be finalized post-construction with record drawing information to reflect any design changes made during construction.
  - g. The final stormwater management facilities operation and maintenance manual shall be submitted to the owner and the City after the project is complete. The project engineer shall inform and make the owner and/or developer aware of the responsibilities of operation and maintenance of the BMPs associated with the project.
  - h. Winter snow removal operations and snow storage shall not negatively impact the function of a stormwater BMP or alter the conveyance of stormwater runoff from the site and/or negatively impact down-gradient property or infrastructure. Snow storage in BMPs can reduce the capacity to handle spring snow melt and early season rainfall flows. Snow storage is not allowed in public ROWs, ditches, stream channels so as to maintain conveyance capacity. Snow melting operations are not allowed in trout stream watershed, and non-trout stream watersheds will need prior approval.

#### MS4 Statement of Compliance

A MS4 Statement of Compliance will be completed by the stormwater engineer for each project upon approval of the drainage report and permanent storm water management system plans. This document shall be signed by the owner and the design engineer and returned to city engineering with payment prior to the issuance of any permits. A

copy of a generic MS4 Statement of Compliance is included in Appendix J. If any design changes need to be made during construction due to site conditions, these changes shall be approved by the City Engineer and shall meet all requirements stated in the MS4 Statement of Compliance and the drainage report. A fee is charged for review of the drainage plans and report and is billed at the time of issuance of the MS4 – SOC. The fees are based on area of new or redeveloped impervious surface. \$300 for 1 acre or less, \$575 for 1 to 5 acres, and \$875 for over 5 acres of new or redeveloped impervious surfaces. These fees are subject to change. The Engineer should inquire with City Engineering prior to submittal to confirm the correct amount.

### Stormwater Sewer/Conveyance Design Requirements

Design of stormwater infrastructure shall meet the following minimum requirements:

1. Minimum grade shall be maintained to provide for a minimum velocity of three feet per second in storm drains (Reference MNDOT DM8.9.4). A target grade of at least 2% should be used for all catch basin leads.
2. Minimum pipe size shall meet the 10-year design requirement or as otherwise directed by the City Engineer. No pipe smaller than 12" diameter.
3. Curb boxes shall not be installed on curb/gutters with continuous longitudinal grades.
4. Combination curb boxes and gutter inlets shall be used at sag points, both at the low point and at the flanking inlets if determined necessary. The engineer shall consider flanking inlets at critical points, especially where overtopping of curb may cause scour and property damage and if road spread exceeds MNDOT design guidelines.
5. A catch basin inlet clogging factor of 50% for sag locations and 25% clogging factor for inlets on continuous grades shall be used for analysis.
6. At each catch basin/inlet, design analysis shall determine the following: flow, spread, runby, and depth of flow in gutter. Runby flows shall be minimized when the flow leaves the project site, and/or up gradient of crosswalks/pedestrian ramps and bus stops. Down gradient inlets and conveyance systems shall be analyzed to determine if sufficient capacity exists to receive the runby flow.
7. When gutter flow requires additional inlets (stacked – in series) due to spread/runby, the inlets shall be spaced a minimum separation distance of 20' center to center of grate.
8. The construction plans shall show overflow paths at all sags for curb overtopping. The plans shall also show the overflow/ flood flow routing and include **ALL** property owners along the overflow routing. Depth of potential ponding on the roadway shall be stated and may require additional review per MNDOT drainage standards. Proof of notification of potentially impacted property owners shall be submitted.
9. For all stormwater BMPs (basins/ponds), show all discharge locations (outlets, spillways, etc.) and flow paths to the down gradient receiving water. Flow paths shall include flood conditions and/or obstructed/clogged outlet pipes. No down gradient property shall have increased flooding risk due to the proposed stormwater management plan.

10. Riprap used in ditch sections shall meet MNDOT 3601 Riprap Material, noting 3601.2 A.1.
11. Geotextile fabric shall be installed under all riprap. Granular filter may be used under the fabric.
12. Precast concrete manholes and catch basins shall be used for all installations unless approved otherwise by the City Engineer. Catch basins shall not have a sump area, unless utilized as a water quality CB/MH with a minimum 4' sump with a floatable debris skimmer or trap and energy dissipation device.
13. Storm manholes shall have concentric cones and no steps.
14. Stormwater pipe shall be reinforced concrete pipe (RCP) or CPP in accordance with the City construction specifications and a minimum of 12" in diameter. CPP should be used for all catch basin leads where adequate cover is available. CPP may be used for storm sewer mains on a case-by-case basis. Other pipe materials may be allowed with approval by the City Engineer or on private property and meeting the plumbing code.
15. Storm sewer piping installed to collect and convey stormwater flow from individual parcels outside of the ROW may be SDR35 PVC.
16. *The City of Duluth has numerous ordinances regarding stormwater management and runoff and the protection of the area's water resources. Please refer to the Duluth, MN - Legislative Code, on the City website – duluthmn.gov.*

## **VI. VACATION AND EASEMENT REQUIREMENTS**

1. All projects requiring vacation of existing right-of-ways or easements shall meet with the City Planning Division to accomplish the necessary vacations. The Planning Division will prepare all vacation documents for Planning Commission and City Council approval upon receipt of legal description and exhibit. The exhibit shall be prepared by the developer's registered land surveyor. No construction plans will be approved prior to vacation or easement dedication approvals.
2. The developer will be required to obtain and/or dedicate any necessary easements. All easements shall be prepared by the developer's attorney and registered land surveyor at the developer's cost. Once approved by the Engineering Division, easements must be accepted by City Council and recorded. Recording shall be done by the City, and all fees invoiced to the developer or subtracted from the deposit. No construction plans will be approved prior to City Council approval of the easements.
3. See Appendix G for additional guidance regarding vacations and easements.

## **VII. PLAN SUBMITTAL REQUIREMENTS**

1. All project plans with infrastructure proposed to be owned by the City shall be submitted to Engineering for review and signature.
2. Plan and specification submittals to Engineering shall include only items to be turned over to the public, traffic control plans and all erosion control and stormwater facilities (both public and private) including the SWPPP. Items not

intended for review by Engineering should not be submitted; submitted items shall be indicated by a circle in the index of the title sheet.

3. All plan sets submitted to Engineering shall be 11 x 17 inches in size. No other sizes shall be accepted. Five copies of the review plans shall be submitted. One copy of the final set for signature shall be submitted. Email submittals will not be accepted.
4. All final plan sets shall have a title sheet. Minimum information required on the title sheet shall be the project name, year of construction, City project number, project location map, a listing of governing specifications, block containing the name and address of the designing consulting firm, signature blocks for City Engineer, Chief Engineer of Utilities, Chief Engineer of Transportation, a signature block for the engineer of record, and a listing of the quality of underground information with Gopher State One Call number. An example title sheet for City projects is included in Appendix K. A copy of the AutoCAD template is available upon request.
5. Alignment sheet shall show station and offsets for centerline alignment, PC's, PT's, PI's, street intersections, control points, plat monuments, etc. Centerline (C/L) to C/L distance shall be indicated on alignment sheet and plan sheets, tied into intersecting streets at C/L even if intersecting street is not on project. This is used for City's pavement management database. Show existing right of way and any new easement granted as part of the project.
6. Charts shall include:
  - a. Survey control point chart with coordinates and descriptions
  - b. Alignment chart with coordinates, azimuths for alignments, coordinate and station and offsets for alignment points, coordinate and station and offsets for curve data
  - c. Bench mark chart
7. When details from the City's *Standard Construction Specifications* are used and referred to in the plan, an illustration of the detail may or may not be required as directed by the City Engineer. The details referenced in the plan shall be, at a minimum listed in the plan. If a detail is included on the plan in its original form, then it shall include the City of Duluth's detail number. If the detail is modified in any way, the Duluth detail number shall not be included. Any modifications shall be clearly indicated in the construction notes, the plan, and in the special provisions.
8. All plan sets shall use the following AutoCAD standards:
  - a. Minimum text size of 0.08"
  - b. Minimum line weight of 0.1500mm.
9. The projected coordinate system used for all projects shall be the St. Louis County Transverse Mercator System 96:
  - Projection: Transverse\_Mercator
  - False\_Easting: 4757208.33333333
  - False\_Northing: 3280833.33333333
  - Central\_Meridian: -92.45000000
  - Scale\_Factor: 0.99998529
  - Latitude\_Of\_Origin: 46.61666667



- Linear\_Unit: Foot\_US
  - Geoid: (2003)
10. Plan submittal shall include all CAD files used in the plan. Example: base files, sheet files, external references, images, shape files, line-type files, fonts, pipe network catalogs, custom subassemblies, ptp files. The City should be able to verify and review the design data of all custom entities. The City should not have any errors or warnings when opening these files. Include a pdf so the City can reprint exactly what the engineer of record intended the plan to look like.
  11. All plan sets shall clearly indicate that the contractor must obtain any driveway, obstruction or excavation permits required from the City prior to the commencement of work.

## **VIII. CONSTRUCTION INSPECTION**

All public improvements shall have on-site inspection as necessary to confirm that all work adheres to the City approved plans and specifications. Underground utilities shall be inspected on a full-time basis. All inspectors shall be required to obtain and maintain the appropriate inspection certifications for the work they are responsible to inspect.

All materials to be used in the construction must be inspected by the engineer prior to installation. The engineer will confirm that all materials delivered to the project site meet the specification and the reviewed shop drawings. No materials shall be placed until they have been inspected and approved.

## **IX. MATERIALS TESTING**

The engineers will perform materials testing for acceptance and quality assurance on all projects. A schedule for materials testing is included in the *City of Duluth Standard Construction Specification*. This schedule identifies the minimum amount of testing required. Based upon field observations, the engineer shall increase the amount of testing required to ensure contractor compliance with the specifications. The amount of testing shall not be reduced below the amount shown in the schedule.

## **X. SHOP DRAWINGS**

The engineer will review the shop drawings for compliance with the contract documents and current City standards. The engineer will respond with comments (within 14 days of receipt of submittal) to the contractor that the items submitted are either “reviewed” or “resubmit”. The engineer may consider work unacceptable and no payment will be made, if the shop drawing review is not completed for products incorporated into the work.

In addition, the engineer will submit “reviewed” shop drawings for **all water main and fittings** to the Chief Engineer of Utilities for review. The engineer and contractor will schedule a time to meet on the construction site with the Chief Engineer of Utilities to inspect the materials furnished prior to use in the work. No water main work will be considered acceptable and no payment will be made without the completed shop drawing review and inspection of the Chief Engineer of Utilities.

## **XI. POST CONSTRUCTION SUBMITTALS**

The City of Duluth, upon completion of a public project and/or projects requiring City maintenance or inspection, requires that the following data be received, reviewed, and approved by the Engineering Division before permit of occupancy is granted. For City of Duluth projects, final payment for engineering services will be withheld until all final documents have been reviewed and approved. For private projects, acceptance of the street and/or utilities and any deposit paid will be withheld until all final documents have been reviewed and approved.

### Required Post Construction Submittals, as applicable to the project:

- a. Record drawings on 11X17 paper, signed by the engineer of record
- b. Letter recommending acceptance by the City and certifying that project is complete and installed to City standards, signed by the engineer (if project is private or if specified in the MOU)
- c. Letter confirming sanitary sewer mains (if present) were televised, have passed an air test and mandrel test and that all manholes have passed a vacuum test and are acceptable, signed by the engineer
- d. Original plan with signatures (if not bid by the City)
- e. Shop drawings
- f. CAD files for COMPLETE plan set in .dwg format (see XI.A.1. for requirements)
- g. Plan specifications created and submitted in Microsoft Word
- h. Special provisions, created and submitted in Microsoft Word
- i. Pay estimates
- j. Change orders
- k. CSV files of all surveyed shots, including list of point codes and equipment used (see section XI.B for required features)
- l. Inspector field notes, survey field notes, and monument ties
- m. Utility Installation/Modify Documents (Excel version available upon request)
  1. Water main check-off list (Appendix L)
  2. Valve installation record (Appendix M)
  3. Hydrant installation record (Appendix M)
  4. Water service installation records (Appendix M)
  5. Sanitary Sewer Wye Record (Appendix N)
- n. Fusion logs
- o. Materials testing reports
- p. Erosion control inspection reports
- q. Notice of Termination of Stormwater Permit (NOT)

- r. All construction/inspection photos labeled on a CD
- s. PDF copies of IRA's for State Aid jobs, if paper forms were used
- t. Completed ADA pedestrian ramp forms, for State & Federally funded projects (form can be found at [www.dot.state.mn.us/ada/pdf/PDFCurbRampForm.pdf](http://www.dot.state.mn.us/ada/pdf/PDFCurbRampForm.pdf))
- u. Completed ADA form for traffic signals, for State & Federally funded projects (form can be found at [www.dot.state.mn.us/ada/pdf/PDFAPSForm.pdf](http://www.dot.state.mn.us/ada/pdf/PDFAPSForm.pdf))
- v. Stormwater Management Facilities Operation and Maintenance Manual for BMP's (see Section XI. A.3. for requirements)

All post construction submittals shall be delivered to Peggy Billings, Senior Engineering Specialist, in the Engineering Division. Refer questions to [pbillings@duluthmn.gov](mailto:pbillings@duluthmn.gov).

## **A. Record Drawings**

For all projects, prepare complete record drawings whether there were any changes from the "as let" plan or not.

### **1. Record Drawing Requirements**

- a. The original/record drawing plan will be on 11"x17". All pertinent signatures shall be on the original plan. The record drawing shall be signed by the engineer.
- b. CAD files in .dwg format should be submitted in the current Autodesk Civil 3D version used by the City of Duluth, unless prior arrangements have been made.
- c. All corrections will be on record drawing layers. All cross-reference/X-ref drawings, non-standard fonts, catalogs/libraries, and shape files will be part of the electronic copy.
- d. Survey data shall adhere to standards found in SURVEY REQUIREMENTS (Section XII).
- e. The words "Record Drawing" and the date, in red upper-case letters, must be centered in the top margin of the title sheet and at least ¼" high and must be included on all plan sheets.
- f. General sheet changes shall be in red. Line out or cross out all changed original information so it is still readable. Write the corrected information above the original or close to it where possible.
- g. Plan view sheet changes:
  - 1) All changes must be shown and labeled in red. (Reminder that all other line work shall remain in black.) For example:
    - Changes in grade or elevations for footings, culverts, manholes
    - Relocated private drives
    - Sidewalks and curb ramps (new, added, or removed)
    - Changes in size, location, or alignment of pipes. For unusual situations like unexpected angles for pipe fittings, show details and supply labeled photos on the record drawing.
  - 2) Pre-construction and post-construction conditions must be shown; proposed changes need not be shown.
  - 3) Drawings shall contain:

- Stationing and offsets for centerline and sawed X's (see Section XII.5.)
  - Centerline dimension of street to right-of-way line and intersecting streets and right-of-way
  - Sub-cut areas, rock profiles, insulation of utilities
  - Other utilities and underground structures (e.g. vaults) within the right-of-way, including abandoned or discovered utilities and private utilities. This includes fiber optics.
  - Omissions, errors, and discrepancies discovered during construction
  - Features added, revised, or deleted by contract change orders
  - Changes in drainage and altered watercourses; any additional perforated pipe and/or french drains
  - Material type, size and manufacturer where optional materials are allowed by specifications or approved field changes
  - Final pipe dimensions, details, sizes, material, numbers, locations, quantities, length, grades, and invert elevations, if different from the original plan. Elevations for storm and sanitary items shall be shown on the record drawings.
  - Plat monuments in place, placed or replaced. All changes in control points. Corrected or replaced permanent bench marks. Final dimensions, alignments, elevations. Show ties to monuments.
  - All water valves shall have two centerline ties
  - All hydrant valves shall have a dimension from the hydrant to the main and the hydrant to the valve.
- h. Profile view sheet changes:
- 1) Labels should be modified to reflect post construction conditions.
  - 2) Pre-construction and post-construction conditions must be shown; proposed changes need not be shown.
- i. If the plan has no changes, indicate such by the words "NO PLAN CHANGES" on the title sheet. If individual sheets within a record drawing have no changes, indicate such by the words "NO SHEET CHANGES".
- j. If the charts have no changes, indicate such using the words "NOT UPDATED" on the charts.
- k. The title sheet shall reflect the sheets that have been modified by adding (in red) a note to the index.

## 2. Structural Plans – Record Drawing Requirements

Include the following items on the title and detail plan sheets as applicable. This listing should be considered as a base and can be revised to meet individual project needs.

- a. Record drawings for structural plans will be 11 x 17
- b. Corrected or new bench mark disk locations and elevations
- c. Added or relocated utilities: Locate on the plan sheet and on the detail sheet if hanging from the superstructure

- d. Changes in piling type and length: Note the range in length (shortest to longest) on the plan view of each substructure unit
- e. Added or relocated piles, location, type and length
- f. Expansion joint types where options are allowed: Indicate the size and manufacturer, cross-out reference to joint type not used
- g. Revisions, additions and deletions per contract change order
- h. Final dimensions, alignments, elevations, detail sizes, lengths, numbers, and locations if changed from the plans
- i. Controlling vertical clearances
- j. Plain and protective surface treatment color, type, and manufacturer
- k. Size of riprap or other countermeasures to counter erosion/scour
- l. Underwater problems encountered that may reoccur
- m. Top of water elevation together with date taken
- n. Vulnerability to scour code obtained from bridge designer
- o. Profiles and cross sections of stream bed upstream and downstream
- p. Angle of water attack relative to pier of abutment line
- q. Submit Bridge Load Rating Form for bridges

### 3. Stormwater Management Facilities (BMPs) Operation and Maintenance Manual

For all BMP's, public and private, provide as-built information for Stormwater Infrastructure and verification that the as-built condition meets or exceeds the designed capacity/function of the stormwater management facility as developed for the Drainage Report and construction plans. Stormwater BMPs are site-specific, vary in design, and may be comprised of many components. As-built information shall be collected using survey grade instruments and shall include a full topographic survey of all components of a BMP and pertinent features including but not limited to the below items.

#### Required Post Construction Submittals for BMP's:

- 1. Record drawing
- 2. Statement that the system was construed to the project construction plan and specifications, signed by the engineer
- 3. Shop drawings
- 4. CAD files
- 5. CSV file
- 6. Copies of field notes and survey notes
- 7. Drainage report (if modified)
- 8. Photos
- 9. O & M Manual

#### Requirements for Stormwater Management Record Drawings

- a. Ponds: Wet Sedimentation
  - 1. Elevations/areas/volumes: bottom of pond, NWL, EOF and top of perimeter berm (entire length)

2. Forebay areas: bottom invert, NWL, overflow elevation
- b. Underground Detention
  1. Elevations/areas/volumes: bottom of system: structure, rock bed
  2. Inverts of structure, pipes (size/type), sub-drains (size/type), inlets and outlets of system
  3. Shop drawings
- c. Filtration/Infiltration Basins
  1. Elevations/areas/volumes: top of berm (entire length), EOF, top and bottom of filtration media
  2. Inverts of structure, pipes (size/type), sub-drains (size/type), inlets and outlets of system
- d. Water Quality Units and Pretreatment Structures
  1. Brand: size/model, manufacture/design schematics
  2. Structure: inverts in/out, invert/diameter/configuration of orifices, weirs or other flow control devices, invert of structure, top of casting(s)
  3. Shop drawings
- e. Outlet Control Structures and Diversion Manholes
  1. Inverts in/out, invert/diameter/configuration of orifices, weirs or other flow control devices, invert of structure, top of casting(s)
  2. Structure size and depth
  3. Shop drawings
- f. Conveyance of Stormwater Management System (up/down gradient of BMPs)
  1. Pipes: size, material type, slope
  2. Manhole/Catchbasin: top of casting elevation, inverts in/out, structure size/depth.
  3. Swales/Ditches: width, shape, slope, restoration/finish surface (riprap, TRM, grass, etc.), ditch checks/other energy dissipation BMPs (type, height, spacing, material)
  4. Site grading to verify that run-off is conveyed as planned

## **B. Electronic Survey Data Submittal**

In addition to the record drawings required above, the engineer shall furnish digital comma separated value (CSV) files for all projects with public improvements to provide location data for the following features:

- a. Sanitary manholes, sanitary wye connections, sanitary service bend fittings, sanitary service end caps and extensions, sanitary sewer couplings, the sanitary sewer pipe alignment, and tracer wire boxes
- b. Storm manholes, catch basins, storm aprons, storm culvert ends and aprons, stormwater treatment BMP boundaries, private service connections, and storm pipe alignments
- c. Water main valves, water hydrant valves, water hydrants, water end caps, water pipe fittings, water service connections, water service valves, electrofusion couplings, and the water main pipe alignment: All water main shots must be taken on the pipe unless the pipe is installed by trenchless methods.

- d. Gas main valves, gas service valves, gas tees, excess flow valves and the gas main/service alignment (include elevation): All gas main shots must be taken on the pipe unless the pipe is installed by trenchless methods.
- e. Infiltration and inflow pipes, private service connections, service bend fittings, service end caps, and service extensions
- f. Alignment points including centerline, control points, sawed X's, and monuments
- g. Street light poles, traffic signal poles, street signs and all underground power and telecommunication lines associated with these facilities
- h. New or removed street signs and traffic signs
- i. Elevation data is required on ALL survey shots

For water main and gas main, the maximum interval of survey shots on the pipe shall be 25 feet. Closer shots shall be taken if the pipe is not laid straight.

The CSV files will provide field names along the top row that include feature name, northing, easting, elevation (natural gas only), and date coordinates captured. The dataset shall be in the coordinate system specified under plan submittal requirements. All coordinates within the CSV files shall be collected during and following construction and reflect the actual installed conditions.

## **XII. SURVEY REQUIREMENTS**

The City of Duluth has established the following minimum requirements for survey data for the professional engineer and the developer to follow during the development, design, construction, and record drawing submittal for their project. The City of Duluth's Engineering Division shall receive all original survey field notes, including all monument ties.

### **1. Utilities**

- a. The horizontal accuracy of coordinates for buried items shall be within 0.5 foot.
- b. The horizontal accuracy of coordinates for exposed or above grade items that may be collected as part of the record drawing survey shall be within 0.1 foot.
- c. Vertical elevations items other than storm or sanitary sewer related objects shall be within 0.2 feet.
- d. Storm and sanitary sewer invert elevations shall be within 0.05 feet.

### **2. Horizontal Control Points**

- a. Use St. Louis County/Transverse Mercator 96 - NAD 83, in U.S. Survey Feet with no more than 0.05 Ft. accuracy used for setting control, alignment control, sawed X's, and monuments.
- b. Control Points shall be tied to minimum of two "HARN" monuments. (HARN monuments are available from St. Louis County and MNDOT.)

- c. Control points shall be placed so that pairs of points are visible from one another.
- d. Post Construction control points (sawed X's, see Final Record) shall be placed after project completion, for future reference.

### 3. Bench Marks

- a. Vertical Datum shall be NAVD 88 Datum with at least 0.01 Ft. accuracy.
- b. Verify elevations by tying into two (when practical, 1 minimum) USGS Bench Marks that have been adjusted to NAVD 88 Datum.
- c. Close bench circuits to assure accuracy.
- d. Permanent bench marks should be set at every intersection and indicated on plans. Spikes in poles, tops of hydrants, spikes in trees, etc. are all examples.

### 4. Monuments

- a. Reference "Survey Monumentation Preservation" memorandum dated October 31, 2001, and Minnesota statutes including but not limited to section 160.15 and section 505.02.
- b. All existing plat monumentation, used or impacted by the project, must be researched, field verified, maintained, tied out, and replaced if destroyed.
- c. Plat monuments shall be used to establish location of right-of-way, easements, roadway center lines, etc.
- d. Roadways shall be tied to existing plat monumentation and be centered on the right-of-way. Exceptions must be approved by the City Engineer.
- e. When survey monuments are required by the City, the City shall supply castings, the cost of which shall be deducted from the developer's deposit. The Developer's surveyor shall set the monument. Refer to the *City of Duluth Standard Construction Specifications* for Duluth Standard Detail Sur 1, Survey Monument Installation.
- f. Notify appropriate governmental agency (County, MNDOT, USGS, etc.) of changes and or additions.
- g. By Minnesota statute, government corner monuments are to have certificate filed with County Land Surveyor's office; St. Louis County Land Surveyor's office will also accept certificates on plat monuments.

### 5. Final Project Control

Final project control shall consist of sawed X's placed on top of the curb on both sides of the street to re-establish the alignment after construction. The X's must be placed by the Developer or Consultant's surveyor within one week after the curbs are placed. The X's must be set before the Record Drawings are submitted.

- a. Sawed X's, about 3" x 3", shall be placed on the top of curb near the PC and PT of the intersections. The X's shall be placed on both sides of the street on a stable part of the tangent curb close to the PC or PT at an even +05, +10,



- or +20 etc. station. Label the station and offset on the curb with white spray paint. Example: 12+05 12.5' CL, where the sawed X is the + of the station.
- b. The X's must be placed on tangents near the beginning and end of every block at an even foot stationing LT and RT. Sawed X's must also be placed at all horizontal PC and PT of the roadway centerline.
  - c. The offset of the X's should be at an even offset from centerline and land on top of the curb. Example: 14.67' from centerline to back of curb, put the sawed X at 14.5'. Label the station and offset on the curb with white spray paint and shoot x, y, z of the sawed X's to submit with final records.

### **XIII. MISCELLANEOUS REQUIREMENTS**

#### **A. City Expenses**

For all private projects, the City shall invoice the developer for all City costs associated with the public improvements, including, but not limited to, costs associated with plan review, recording fees, construction inspection by City personnel, testing, including televising of underground utilities, survey monuments, and the review and acceptance of the public utilities.

The City may require within the Memorandum of Understanding that the developer tender a deposit with the City against which the developer authorizes the City to draw for payment for City expenses. The amount of this deposit and determination of the need for a MOU will be decided on a project specific basis. A typical MOU is provided in Appendix A.

#### **B. Warranty**

All privately constructed projects shall have a warranty for a period of two (2) years for all public improvements turned over to the City. Such warranty shall include, but not be limited to, repairs or corrective action due to improper construction or compaction. The warranty period shall commence upon acceptance of the project by the City Engineer.

**APPENDIX A**  
**Example: Memorandum of Understanding (MOU)**

**MEMORANDUM OF UNDERSTANDING**  
**between**  
**City Engineer for the City of Duluth, MN**  
**and**  
**Owner's name**  
**relative to**  
**Name of Development, Duluth, Minnesota**

This will serve as a Memorandum of Understanding between the City Engineer (“City Engineer”) of the City of Duluth, Minnesota (“City”) and [REDACTED] (“Developer”) and will document specific understandings of both parties relative to the construction of public and private improvements associated with the development of the [REDACTED] project within the City of Duluth, Minnesota. The public and private improvements, herein after referred to as the “Development” are shown on the attached Exhibit A. **Attach Exhibit**

Whereas, the Developer – as part of the Development – intends to proceed with the design and construction of public improvements at no cost to the City (City Project No. [REDACTED]) and which improvements, upon completion of construction, will be turned over to the City for ownership, operation, and maintenance, and

Whereas, the City Engineer, in his or her capacity as city engineer for the City, has the authority to require that the public improvements constructed by a developer, which are to be turned over to the City and for which the City is to assume responsibility for maintenance and operation, be constructed in accordance with applicable City standards as determined by the City Engineer in the exercise of his or her discretion; and

Whereas, when such public improvements are so constructed, the City Engineer has the authority, in the exercise of his or her discretion, to accept such improvements and to undertake to have them maintained and operated by the City; and

Whereas, the Developer – as part of the Development – intends to proceed with the design and construction of private improvement at no cost to the City which improvements upon completion of construction will be retained by the Developer for ownership, operation and maintenance, and

Whereas, both the City Engineer and the Developer wish to memorialize various understandings relative to the public improvements for the Development.

Now, therefore, as indicated by signatures of appropriate representatives for both parties on this Memorandum of Understanding, it is jointly understood that:

1. The Developer intends to construct the public improvements within the Development privately and intends to turn over these improvements to the City of Duluth upon construction completion and acceptance by the City. The Developer agrees to dedicate

any necessary utility easements and access rights of way within the Development to the City prior to the construction of the utilities and prior to the City's acceptance of those utilities.

2. The Developer intends to construct private improvements within the Development which will remain private following construction, and the Developer will be responsible for the ownership, operation, and maintenance of those improvements.
3. The design of all public improvements covered by this agreement shall conform to the most current edition of the Engineering Guidelines for Professional Engineering Services and Developments as approved by the City Engineer and on file in the office of the City Engineer. All public improvements shall have been approved in writing by the City Engineer prior to the commencement of the construction, thereof. Thereafter, any changes in said plans, other than standard field modifications, shall be similarly approved.
4. The construction of all public improvements covered by this agreement shall conform to the most current edition of the Engineering Guidelines for Professional Engineering Services and Developments as approved by the City Engineer and on file in the office of the City Engineer. All construction of the public improvements will be inspected on a full time basis by the engineering consultant. The Developer shall require by contract that its engineering consultant deem the City Engineer and the City to have the status of a "client" of such consultant for purposes of the work performed by such consultant related to the Development, and particularly as such status reflects on the consultant's duties to provide accurate and timely information and reports to their clients on the progress of such work and problems related thereto, all in accordance with professional standards common to the profession within the area. It is currently understood by both parties that **?????** will serve as the Developers engineering consultant for the design and construction of the public improvements.
5. Prior to the City Engineer's approval of the plans and specifications for the public improvements, the Developer will tender a deposit of **???? (DEFINE AMOUNT – typically 20% of construction cost)**, against which the Developer authorizes the City to draw for payment of City costs associated with the public improvements, including, but not limited to, costs associated with plan review, construction inspection by city personnel, testing, including televising of underground utilities, and the review and acceptance of the public utilities. In addition, the Developer understands that the deposit may be used to correct work not performed or work requiring corrective action whether or not such work is warranted as provided for in **Paragraph 15** below or not, if the

Developer's contractor fails to complete the work to city standards or to correct defects in such work in accordance with the requirements of this Agreement.

6. **(DELETE THIS IF NO SANITARY SEWER IS BEING CONSTRUCTED)** As part of the public improvements, the Developer will construct sanitary sewer mains with sufficient capacity, as determined by the City Engineer, to receive all sanitary sewer flows anticipated to be required for any and all future development as is currently known or expected to occur within the area which would be served by such utilities as determined by the City Engineer. In addition, the Developer will meet the conditions of the sanitary sewer system extension permit from the Minnesota Pollution Agency (MPCA) as required for the Development.
  
7. **(DELETE THIS IF NO WATER MAIN IS BEING CONSTRUCTED)** As part of the public improvements, the Developer will construct water mains with sufficient capacity, as determined by the City Engineer, to provide adequate flow of water for any and all future development as is currently known or expected to occur within the area which would be served by such utilities as determined by the City Engineer.
  
8. Prior to the issuance of individual building permits for a residential development or the Certificate of Occupancy for a commercial building, the Developer's engineer shall furnish record drawings prepared in accordance with City of Duluth Engineering Guidelines. These drawings shall indicate all changes made during construction. In addition to the record drawings, the Developer's engineer shall furnish digital comma separated value file (CSV) files to provide location data for the following features:
  - Sanitary manholes, sanitary wye connections, sanitary service bend fittings, sanitary service end caps and extensions, sanitary sewer couplings, the sanitary sewer pipe alignment, and tracer wire boxes.
  - Storm manholes, catch basins, storm aprons, storm culvert ends, storm water treatment BMP boundaries, private service connections, and storm pipe alignments.
  - Water main valves, water hydrant valves, water hydrants, water end caps, water pipe fittings, water service connections, water service valves, electrofusion couplings and the water main pipe alignment.
  - Gas main valves, gas service valves, gas tees, excess flow valves and the gas main/service alignment (include elevation).
  - Infiltration and inflow pipes, private service connections, service bend fittings, service end caps, and service extensions.
  - Alignment points including centerline, control points, sawed X's, and monuments.
  - At this time, elevation data within the CSV file is only required on natural gas related items.

The CSV files will provide field names along the top row that include Feature Name, Northing, Easting, Elevation or Depth, and Date coordinates captured. The dataset shall be in the following coordinate system:

Projected Coordinate System: St Louis County Transverse Mercator System 96  
Projection: Transverse\_Mercator  
False\_Easting: 4757208.33333333  
False\_Northing: 3280833.33333333  
Central\_Meridian: -92.45000000  
Scale\_Factor: 0.99998529  
Latitude\_Of\_Origin: 46.61666667  
Linear Unit: Foot\_US  
Geoid: (Current)

All coordinates within the CSV files shall be collected during and following construction and reflect the actual installed conditions. Survey data shall adhere to the following standards:

- The horizontal accuracy of coordinates for buried items shall be within 1.0 foot.
- The horizontal accuracy of coordinates for exposed or above grade items that may be collected as part of the record drawing survey shall be within 0.1 foot.
- Vertical elevations items other than storm or sanitary sewer related objects shall be within 0.2 feet.
- Storm and sanitary sewer invert elevations shall be within 0.05 feet.

9. **ARE THERE ANY STORM WATER IMPROVEMENTS THAT NEED TO BE MAINTAINED IN THE FUTURE BY THE DEVELOPER OR THE HOA?** As part of the private **public?** improvements, the Developer will construct a storm water system including permanent storm water quality improvements. The storm water system will have sufficient capacity to receive all storm water flows for any and all future development as is currently known or expected to occur tributary to the project area. Developer agrees to forever maintain and repair as necessary the permanent storm water improvements to be constructed as a partial requirement of the MPCA NPDES Stormwater permit and the City of Duluth Municipal Separate Storm Sewer System (MS4) Stormwater Permit. Changes to the storm water improvement construction or operation must be reviewed and approved by the City Engineer. All work to be performed by the Developer under this paragraph, including work or modifications carried out at the request or direction of the City, shall be paid for solely by the Developer and its successors in interest, if any, and at no cost to the City. The installation of all private water quality structures on this project shall be inspected on a

full-time basis similar to public improvements and the engineering consultant shall certify the installation to the City Engineer. Record drawings will be provided for all private water quality structures.

10. The Developer will give formal notice to the City Engineer upon completion of the public utility improvements via certification by the Developer's engineering consultant that the public improvements have been constructed in complete accordance with applicable City engineering standards, as well as the approved plans and specifications. Upon receiving such notice/certification and record drawings, the City Engineer will inspect the public improvements. If the public improvements are in conformance with the applicable requirements, the City Engineer will direct that the City will assume ownership, operation and maintenance of them. If the public improvements are not in conformance with the applicable requirements, the City Engineer will provide formal notice to the Developer of the need for repair or replacement before the City assumes ownership, operation, and maintenance of them.
11. Until such time as ownership, operation, and maintenance of the public improvements is formally accepted in writing by the City Engineer, their operation and maintenance will be solely the responsibility of the Developer. This includes locating of pipes in accordance with the requirements of the Gopher State One Call System and plowing of snow for new City Streets.
12. Future repairs of public utilities will be completed by the City or their designated contractor. Following excavation for any utility repair on private property, the Developer is responsible for final surface restoration.
13. The Developer hereby agrees that it will defend, indemnify and hold harmless the City, the City Engineer and all other officers, agents, servants, employees and contractors of the City from and against any and all liability arising in any way out of the design and construction of the Development and, upon ten (10) days notice from any such party will appear and defend such party against any action of any kind arising out of this obligation. Provided, however, that nothing herein shall be deemed to require the Developer to defend, indemnify or hold harmless any such party from Liability arising out of such party's active or intentional negligence or intentional acts; provided, however, that such obligation shall not apply to such liability arising from the ownership, operation and maintenance of the improvements as undertaken by the City.
14. The Developer agrees that it will require that the City Engineer and the City be named as additional insured on all insurance policies required by the Developer from its engineering consultant as referred to in **Paragraph 4** above and from all contractors

providing services to the Development and will require that certificates of insurance be promptly furnished to the City Engineer evidencing such coverage.

15. The Developer agrees to warranty the streets and utilities that are turned over to the City for ownership for a period of two (2) years after acceptance by the City Engineer. Such warranty shall include, but not be limited to, repairs or collective action due to improper construction or compaction.
16. Although the City Engineer has the authority to review and approve various plans and specifications for the improvements to be constructed as part of the Development, the City Engineer is not to be considered the project engineer for the purposes of the design or construction of the Development's streets and utilities, and the approval of the City Engineer of the design or construction or both of said streets and utilities shall not be a guaranty of the sufficiency or quality of said streets or utilities or of their compliance with codes applicable to such work. The City Engineer shall not be responsible for any errors or omissions of any kind whatsoever related to the design or construction of such improvements or any damages arising therefrom including consequential damages, whether to the Developer, to its engineering consultant or to any third party. The Developer agrees that, as between itself and the City and the City Engineer, it shall be solely responsible for any liability arising out of the design and construction of such improvements.
17. The Developer agrees to make repairs to public streets that may become damaged due to use of the road for hauling of materials, or due to the contractor's construction practices. The Developer shall repair such damage in a manner as so that it is acceptable by the City Engineer. Any pavement repairs shall be completed prior to final acceptance of any public improvements.
18. This Memorandum of Understanding may be executed in two or more counterparts, each of which shall be deemed an original, but all of which together shall constitute one and the same instrument.

City Engineer of Duluth, Minnesota

Developer

Cindy Voigt, P.E.  
City Engineer

Name  
title

Date: \_\_\_\_\_

Date: \_\_\_\_\_



I acknowledge that I have read and understand the above document.

Engineering Consultant

name

title

Date: \_\_\_\_\_

**APPENDIX B**  
**Application to Make Public Improvements Privately**

## APPENDIX B

### Application to Make Public Improvements Privately

---

Application Number \_\_\_\_\_ Date \_\_\_\_\_  
 Project Number \_\_\_\_\_

#### City of Duluth Engineering Division Application to Make Public Improvements Privately

Application is hereby made to (describe proposed improvements):

I/we hereby agree to do all work relating to the above described project in accordance with the plans and specifications approved by the city engineer.

I/we agree to pay all city costs incurred on the project in accordance with Chapter 45, Article VII of the Duluth City Code and amendments thereto.

I/we hereby tender a deposit of (AS PER MOU, IF APPLICABLE) \_\_\_\_\_, against which I/we authorize the city to draw for payments of such costs. I/we further understand that this deposit is not guaranteed to be the actual costs and agree to reimburse the city for such additional costs if such costs should exceed this deposit. The city agrees to refund any excess upon completion and acceptance of said work.

Upon completion to the satisfaction of the city engineer, I/we hereby ask the city to accept the above described project as a public improvement.

Name of Applicant(s)	Signature	Address	Date

\*\*\*\*\*  
**Permit for Public Improvements Made Privately**  
 Permit Number \_\_\_\_\_ Date \_\_\_\_\_

This is to certify that \_\_\_\_\_ (contractor) has been granted permission to make public improvements as described above in accordance with Chapter 45, Article VII of the Duluth City Code and amendments thereto and agrees to complete this project on or before \_\_\_\_\_ (date).

\_\_\_\_\_ copy to project file  
 (initial)

\_\_\_\_\_  
 Permittee (contractor)

\_\_\_\_\_ copy to insurance file  
 (initial)

\_\_\_\_\_  
 Approved by City of Duluth

**APPENDIX C**  
**Special Assessment Policy for New Development**



City of Duluth  
DEPARTMENT OF PUBLIC WORKS/UTILITIES  
Engineering Division  
211 City Hall \$ Duluth, MN 55802  
(218) 730-5200 Fax: (218) 730-5907

**TO:** Dave Montgomery  
**CC:** SAB  
**FROM:** Cindy Voigt  
730-5107  
**DATE:** May 9, 2017  
**RE: Developer Deposits and Credit Risk**

### **BACKGROUND**

Developer requirements for special assessment projects are currently outlined in past policy, and include these items:

1. Developer to provide credit references (8/31/93)
2. Developer to provide 20% deposit (8/04/94)
3. Developer to pay engineering costs (1/16/01 and 3/09/04)

### **REASON FOR BOARD DISCUSSION**

To clarify and update SAB policy on credit review and deposit requirements, as it relates to a Developer. I suggest that "Developer" requirements apply to anyone engaged in "development" of property as defined in city code section 50-41.4 which requires construction of a structure and grading, such development also requires the division of land or platting of property. I suggest that assessment projects that have existing homes or structures are not considered new development, and as such are not subject to the Developer requirements of the Special Assessment Policies referenced above.

We are bringing this up for SAB discussion because recently we have had individual property owner assessment requests where the ability to pay the assessment was questioned, as well as a new development inquiring about having the public improvements assessed to the property.

### **ACTION RECOMENDATATION**

Adopt a policy that any assessment project with a property owner that has an existing structure on the parcel with a taxable value greater than the estimated project cost not be considered a "Developer" and will not be subject to an application. However, the city will complete a review of outstanding taxes or debts owed to the state, county, or city. This policy only applies to assessment projects that are petitioned.

For Developers, require that they complete the following prior to the council ordering in the project by resolution:

- Complete an application form that will be used to review the applicants' ability to deliver a successful project, and verify that there are no outstanding state, county or city taxes or fees associated with the property to be developed or the Developer.
- Submit the down payment based on the estimated project cost.

The down payment will be subtracted from the final project cost to be assessed. In the event that a down payment is submitted, and the city incurs costs, but subsequently the Developer withdraws the petition for assessment, the city incurred expenses will be deducted from the down payment amount prior to refund.

Clarify that the Developer has the option to hire a consulting engineer to provide design engineering services only, and that those costs are not eligible to be included with the assessment. The city or a consultant under contract by the city shall provide for full time construction engineering, inspection, and testing. If the Developer requests that the design services be included in the assessment, those costs will be in addition to the construction engineering and testing services included in the assessment.

Based on the application and the review of any outstanding fees or taxes, the deposit amount may be increased, based on the information provided on the application form, the city's perceived risk and any unfavorable past history with the Developer as determined by the engineering division, upon approval of the SAB. In addition, the SAB will have the authority to consider the application as part of the criteria for Recommending that a project move forward for city council consideration and approval.



# City of Duluth

DEPARTMENT OF PUBLIC WORKS & UTILITIES  
Engineering Division  
411 West 1st Street Room 240  
Duluth MN 55802  
(218) 730-5200 Fax (218)730-5907

## DEVELOPMENT ASSESSMENT APPLICATION

Property Parcel ID \_\_\_\_\_

Property Address \_\_\_\_\_

Property Legal Description (Attach a preliminary plat, site plan or location map.)

Lot \_\_\_\_\_

Block \_\_\_\_\_

Subdivision \_\_\_\_\_

\_\_\_\_\_

\_\_\_\_\_

General Description of Development (Total Length, Acres, Lots)

\_\_\_\_\_

\_\_\_\_\_

\_\_\_\_\_

\_\_\_\_\_

Developer Name \_\_\_\_\_

Mailing Address \_\_\_\_\_

\_\_\_\_\_

Phone Number \_\_\_\_\_

Email \_\_\_\_\_

Development to Serve

Residential single family \_\_\_\_\_ lots

Residential multi family \_\_\_\_\_ units

Commercial or Industrial

Request to Special  
Assess  
(check all that  
apply)

Water Main

Sanitary Sewer

Storm Sewer

Streets

Street Lighting or Traffic Signal

Engineering Costs

Total Estimated  
Assessment Request

\$ \_\_\_\_\_  
(Not to exceed 80% of project cost.)

List names of prior development projects in Duluth. If none, list projects in other cities, including references' contact information. Attach additional pages if necessary.

---

---

---

---

---

---

List any other pertinent information such as planning approvals required, easements or right of way. Attach additional pages if necessary.

---

---

---

---

---

---



**APPENDIX D**  
**Example: Typical Sections**

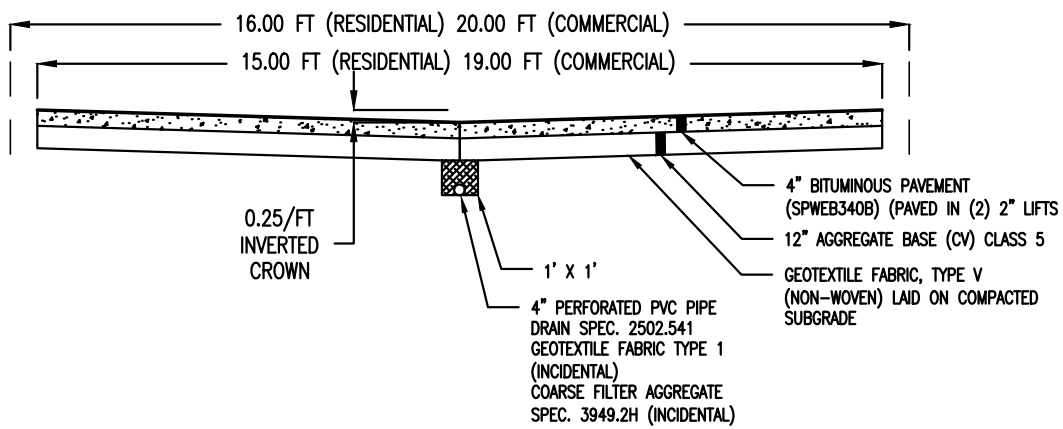

TYPICAL SECTION  
BITUMINOUS ALLEY

BITUMINOUS ALLEY TYPICAL SECTION		D-1
FEB 2022	CITY OF DULUTH STANDARD DETAIL DEPT. OF PUBLIC WORKS AND UTILITIES	NO SCALE

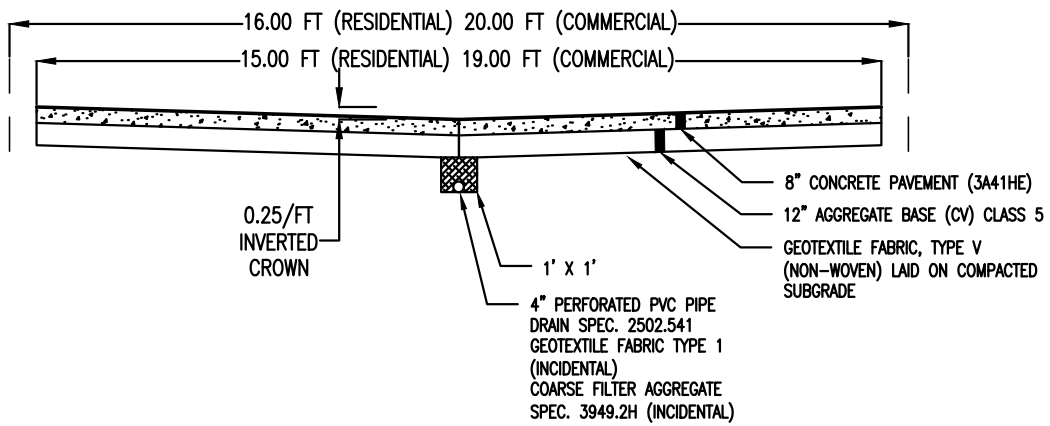

TYPICAL SECTION  
CONCRETE ALLEY

CONCRETE ALLEY TYPICAL SECTION		D-2
FEB 2022	CITY OF DULUTH STANDARD DETAIL DEPT. OF PUBLIC WORKS AND UTILITIES	NO SCALE

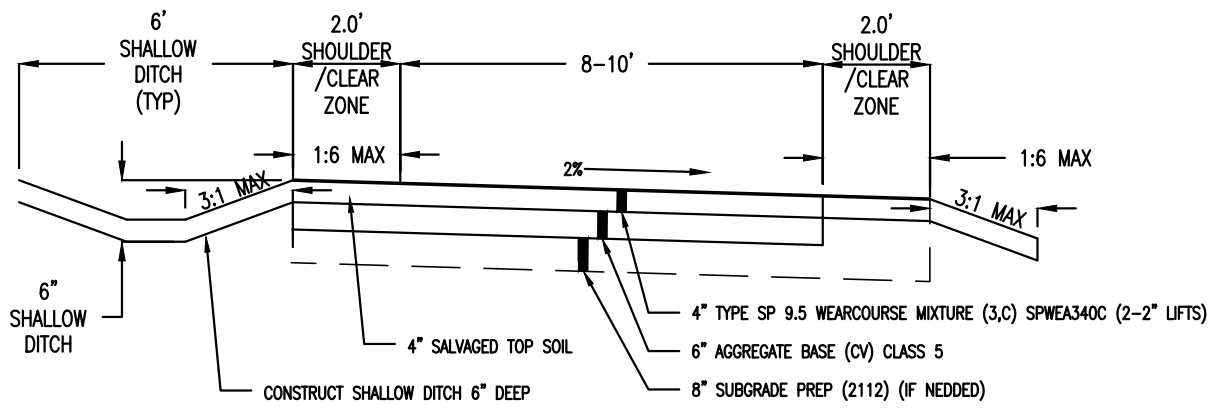

TYPICAL SECTION  
SHARED USE PATH

SHARED USE PATH TYPICAL SECTION

D-3

FEB 2022

CITY OF DULUTH STANDARD DETAIL  
DEPT. OF PUBLIC WORKS AND UTILITIES

NO SCALE

I:\PWU\ENGINEER\Administration\SOP's\Engineering Guidelines Document\January 2022\Appendix D typical sections\URBAN STREET WITH SIDEWALKS TYPICAL SECTION.dwt, B-SIZE DTL, 1/31/2022 11:02:11 AM

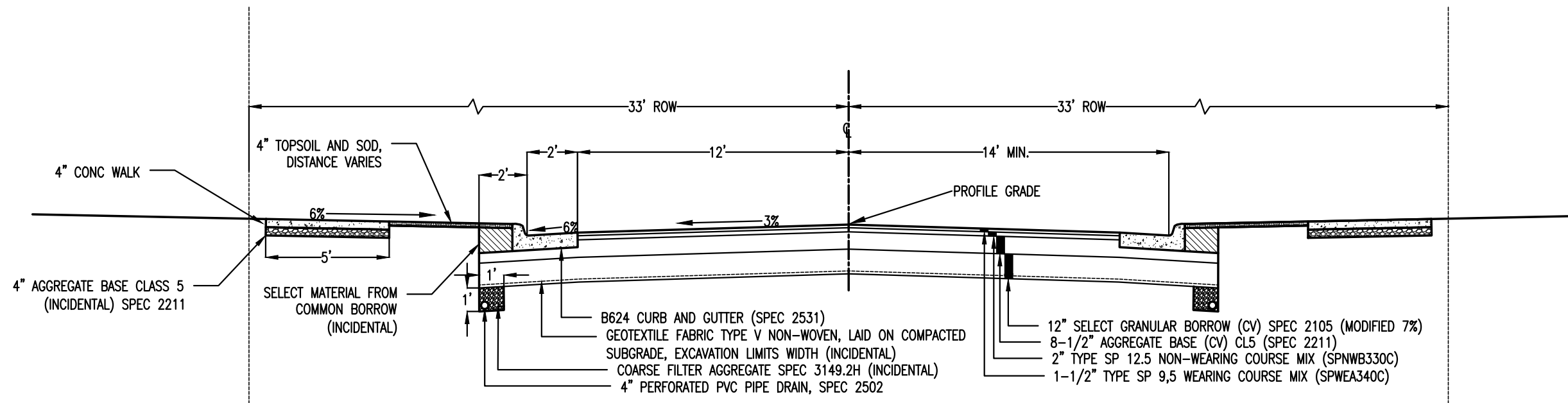

**TYPICAL SECTION  
URBAN STREET WITH SIDEWALKS**

I HEREBY CERTIFY THAT THIS PLAN WAS PREPARED BY ME OR UNDER MY DIRECT SUPERVISION AND THAT I AM A DULY LICENSED PROFESSIONAL ENGINEER UNDER THE LAWS OF THE STATE OF MINNESOTA.

SIGNATURE: \_\_\_\_\_

ENG NAME HERE  
TYPE NAME

DATE: 2/1/2022

LIC. NO: REG NUMB HERE



CITY OF DULUTH  
ENGINEERING DIVISION  
411 W. 1ST ST. STE. 240  
DULUTH, MN 55802

D-4 TYPICAL SECTION - URBAN

CITY PROJECT NO.: CITY PROJ NO HERE

STATE AID PROJECT NO.: NA

DRAWN BY: MLT

URBAN STREET W/ SIDEWALK TYPICAL SECTION

SHEET NO. ---- OF 56 XX

**APPENDIX E**  
**City of Duluth Driveway Entrance Requirements**

# CURB CUTS - DRIVEWAY APRONS

3/8/2022

The driveway *itself* requires no permit.

## PERMIT REQUIRED FOR:

- 1) Any NEW driveway apron: (a) with or without a curb  
(b) with or without a culvert
- 2) WIDENING an EXISTING apron WITH A CONCRETE or BITUMINOUS CURB or a CULVERT.
- 3) REDO an EXISTING driveway apron--replacing the existing materials. It doesn't matter if the present apron is gravel, blacktop, or concrete as long as it's EXISTING.

## NO Permit Required for:

- 1) Re-blacktop an existing blacktop driveway and/or apron: (a) with or without a curb  
(b) with or without a culvert
- 2) On a blacktop or gravel street, blacktop an existing gravel apron

## NOTE:

**\*\* If the work involves the sidewalk (the sidewalk will be removed and replaced), a permit will be required in all cases. \*\***

## General Information

It **IS NOT** permissible to place blacktop in the gutter to relieve the bump at the driveway entrance.

- A concrete street requires a concrete driveway apron.
- Blacktop streets with a concrete curb and gutter require a concrete apron.
- Blacktop streets without a curb/gutter or with a blacktop curb/gutter will use a blacktop or concrete apron.
- Gravel streets may use a gravel or blacktop apron.

Driveway aprons can be constructed over sewer/gas/water mains.

The driveway itself or the *flare* of the apron, can be placed right on the property line. However, putting a driveway that close to a property line means working on a neighbor's property just to construct the driveway or apron. Also, simply getting into or out of a car might also need to be done on a neighbor's property--that property owner may object.

With street improvement projects, the contractor may replace an existing apron or construct a new concrete driveway apron (if a gravel or blacktop apron is in place). Usually, there will be no charge to the property owner; however, on occasion, an assessment may be levied along with the assessment for the street improvement.

- With no sidewalk, the contractor must construct the driveway apron to a minimum of three feet behind the curb.
- With a sidewalk, the contractor must construct the driveway apron to the public sidewalk (as the sidewalk is considered the nearest public improvement from the street).

**EXCEPTION: IF** the boulevard is ten feet or more in depth, concrete is not necessary all the way to the sidewalk. Concrete is only required for the first three feet of the apron; blacktop may be used to complete the apron to the sidewalk.

## TO OBTAIN A PERMIT FOR A CURB CUT (driveway apron)

- 1) Complete an application for a curb cut.  
Send/give specifications sheets as well.  
Be certain applicant sketches a drawing of his/her proposed construction.
- 2) For streets/avenues not requiring a culvert, a front counter technician may approve the application.
- 3) If a culvert is necessary or possibly necessary, follow Culvert Installation Policy instructions.
- 4) An insured and bonded contractor must be engaged to install the actual driveway apron (as the work is being done in the right-of-way).

5) Excavation Permit/Driveway permit issued for \$108.00 to the contractor.

curb cuts - driveway aprons



**APPENDIX F**  
**Policy on the Issuance of Driveway Permits for Private**  
**Improvements in Right-of-Way**

# **Policy on the Issuance of Driveway Permits for Private Improvements in Right-of-Way**

---

## **Policy on the Issuance of Driveway Permits for Private Improvements in Right-of-Way**

### **Background**

Prior to the August 15, 2008 Minnesota Supreme Court case *Bolen v Glass*, the issuance of driveway permits on unimproved “paper” right-of-way was done only if easements from all abutting parties were obtained. This was considered a private property matter. Based on the ruling in the case, it was decided that the City was the trustee of the right-of-way and had the authority to determine when and how the right-of-way is improved. The City has the authority to issue a permit for private improvements within the dedicated right-of-way. It was also determined that the owners of property within a plat have the right to use the right-of-way for access purposes, subject to the issuance of a permit by the city.

### **Criteria for Issuing Driveway Permits within Right-Of-Way**

1. If the property is a corner lot with improved frontage and the driveway request is on the unimproved “paper” street, a permit may be issued to the owner to construct a private driveway in the unexercised easement between their property and the property adjacent to the easement. See attached Exhibit 1.
2. Driveways requiring additional length beyond the property line of the corner lot shall either be built as public street or alley to City of Duluth “Local Design Standards” or for driveways not constructed to the “Local Design Standards”, the permittee shall be required to obtain private driveway easements from the abutting property owners. In both cases, the city would issue a permit, the permittee would provide the proper bonds and insurance for work within the right-of-way and agree to be responsible for any maintenance and snow removal. See attached Exhibit 2.
3. Any permits issued shall be subject to the following conditions:
  - a) Private driveways shall not be allowed when the street serves other residential developable lots within the plat that may use this driveway for access to their property in the future.
  - b) Private driveway permits will be allowed in residentially zoned areas only--not commercial.
  - c) Private driveways will not be allowed to serve properties that can be further subdivided.
  - d) Prior to issuing the driveway permit, the property owner must sign an “Agreement to Petition for (future) Street Improvement” which needs to be recorded by the city. This helps ensure that in the future, the resident has waived their right to protest the permanent street or alley assessment.
  - e) The property owner will be responsible for maintaining and plowing the private driveway.
  - f) The property owner or contractor will need to have the appropriate bonds and insurance on file for work within the right-of-way.

PRIVATE DRIVEWAY ALLOWED  
WITH PROPER PERMIT FROM ENGINEERING.

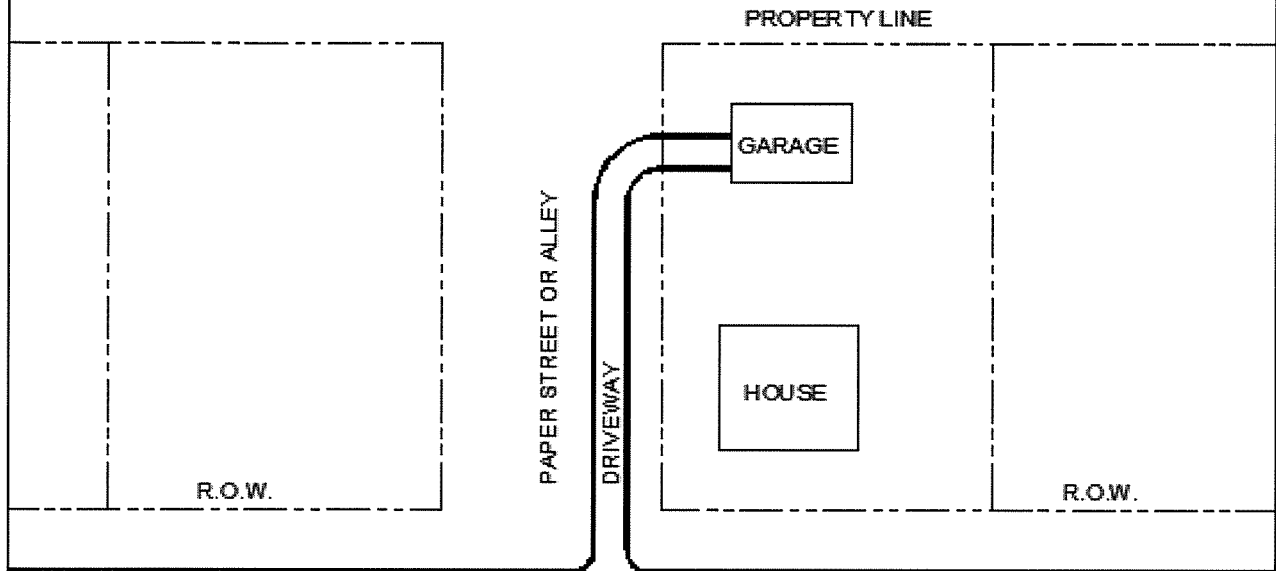

EXISTING STREET OR ALLEY

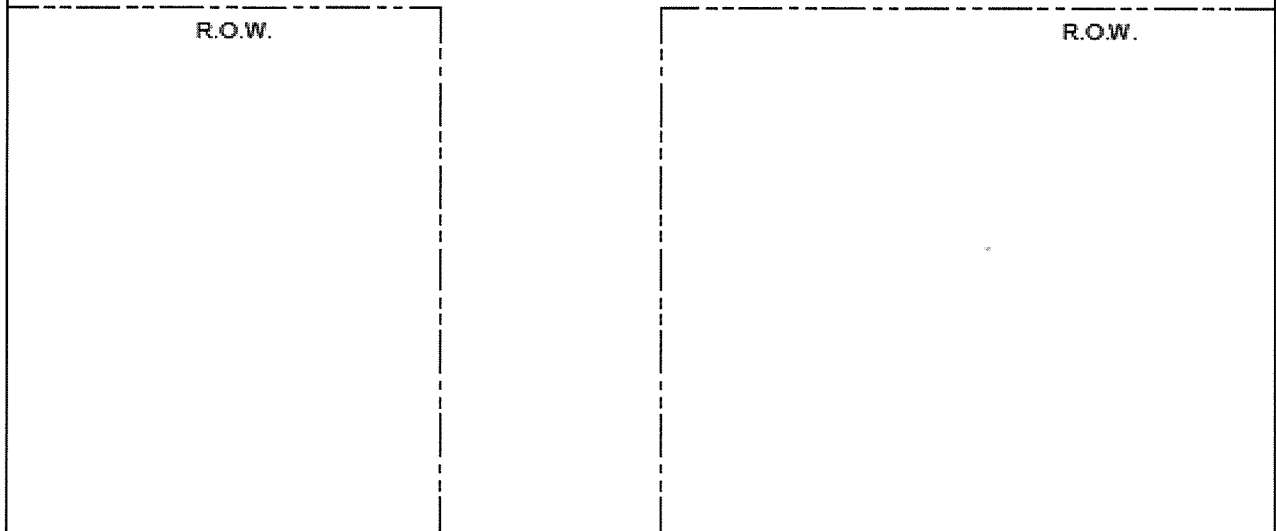

**EXHIBIT 1**  
**PERMIT FOR DRIVEWAY ISSUED**

PRIVATE DRIVEWAY NOT ALLOWED W/O EASEMENT  
FROM ABUTTING PROPERTY OWNERS.

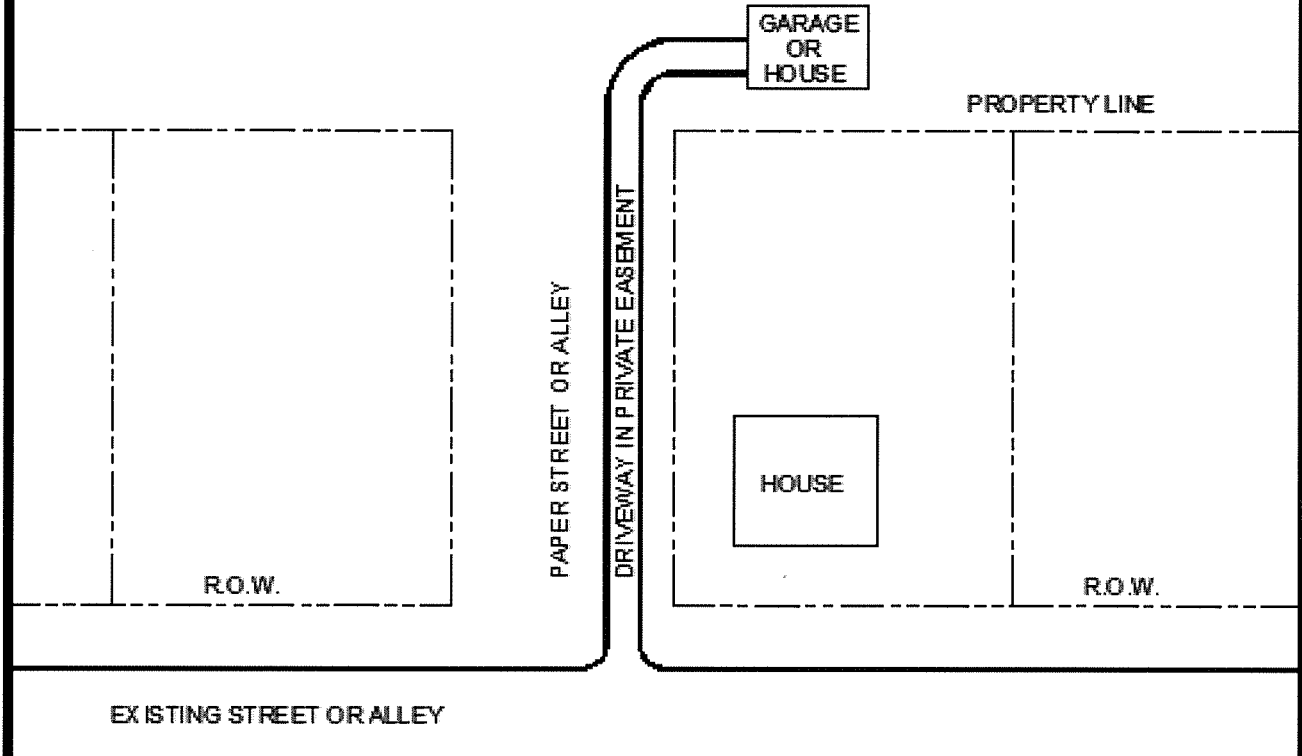

**EXHIBIT 2**  
**EASEMENT FOR DRIVEWAY REQUIRED**

**APPENDIX G**  
**Preparing and Recording Easements and Vacations**



## Engineering

Room 240  
411 West First Street  
Duluth, Minnesota 55802

 218-730-5200

## Preparing and Recording Easements or Vacations

### February 2022 Guideline

The party requesting or requiring an easement shall employ their Attorney and Land Surveyor to prepare a property description and the Exhibit.

- Submit Legal Description with Exhibit to Peggy Billings, Public Works and Utilities Dept., Room 240, 411 W. 1<sup>st</sup> Street, Duluth, MN 55802. The city will review the legal description and exhibit, and will draft an easement agreement.
- If the Recorder requires additional documents, please provide these original documents concurrently with the Easement Description and Exhibit in order to file. An example of additional documents that may be required is if the property is under a Trust. If so provide a copy of the Certificate of Trust and the Affidavit of Trustee.
- The Assistant City Attorney, the Public Works project engineer, surveyor and GIS Staff will review the Easement Agreement and Exhibits.
- The party requesting the easement will modify the Agreement and Exhibit as needed.
- The party requesting the easement will acquire the signatures, except for the City signatures, and convey the original document with the signatures to the City Engineer.
- Public Works and Utilities will then prepare a Resolution for the City Council to consider accepting the easement.
- After the City Council adopts the easement, the City shall file the Easement Agreement with the County Recorder and/or Registrar of Titles. The recording fees charged to the city by the Recorder will be deducted from the Developer Deposit. The process to get a document approved by council and recorded takes approximately 1 month after the city approves the final documents.

#### Requirements for filing:

- Legal Description of the easement and underlying property.
- Marital status of people signing, spouses if married.
- If the property is under a trust, a copy of the Certificate of Trust and the Affidavit of Trustee.
- Acknowledged signature of grantor/grantors (notarized signatures)
- Names of all grantees
- Date
- Drafting statement (who created text of Agreement)
- Submit one original signed Agreement. City will send a copy of the recorded document to the Owner upon our receipt of the document. Provide address or e-mail where you want the document sent.
- For Torrens (registered land) property, the easement must be approved by Examiner of Titles and additional filing fees apply.



## Engineering

Room 240  
411 West First Street  
Duluth, Minnesota 55802

 218-730-5200

County forms for filing: Abstract Filing Request and Torrens Filing Request. The carboned filing forms have tracking numbers in the Abstract and Torrens Offices. The Abstract ones are known as AFR's and the Torrens ones are known as TFR's. These numbers are totally trackable on the County's system.

The Agreement requires an exhibit with a legal description and a sketch, to make it clear to the reviewer and signers of the Agreement what the subject is. This may not be necessary if the easement is bounded solely by a lot created in a recorded subdivision plat.

### Easement/Vacation Sketch requirements:

- Sketch is to be 8.5" x 11", or multiple sheets of that size.
- Do not rely on colored text or lines, as black and white copies will be circulated.
- The minimum size of the lettering font is L80 (0.08 inches).
- Label dimensions referred to in legal description.
- For Metes and Bounds description, label the Point of Beginning.
- North arrow and scale bar.
- Signature line for the Registered Land Surveyor and City Engineer and date.
- If the sketch is on engineering plans, the proposed easement and its dimensioning and references have to be clear and not obstructed with engineering details.
- Engineering plans may be submitted along with the proposed Easement Agreement, to aid the City reviewer in seeing that the proposed easement covers the location of the utility or other improvement, and its future maintenance area needs.
- Include a legend that clearly matches any areas to be vacated with a utility easement retained.
- Do not use shading to show the easement area or other area subject to the legal document as shaded areas do not always show up once recorded. Hatching should be used in place of shading.

### Street Vacation, follow Planning Department and UDC procedures:

- Pre-application
- Land Use Supervisor, City Engineer and GIS review
- Sign notice
- Mail notice
- Planning commission hearing
- Council decision
- Original signed vacation Exhibit document to the Land Use Supervisor.

The Planning Division will arrange to have the vacation recorded.

Developer's requirements for easements are described in City of Duluth – Engineering Guidelines, II.B.1.i.

County Recorder filing fee is \$46 per document as of 1/1/19.



## Engineering

Room 240  
411 West First Street  
Duluth, Minnesota 55802

 218-730-5200

The Engineering Division is responsible for filing Agreements for utility easements. The Planning Division is responsible for filing vacations. In both cases, the recording of the documents is completed by Danielle Erjavec.

I:\PWU\ENGINEER\Administration\Right of Way & Easements\Guidelines and Process\February 2022 Guidelines.docx



# Exhibit A

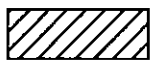
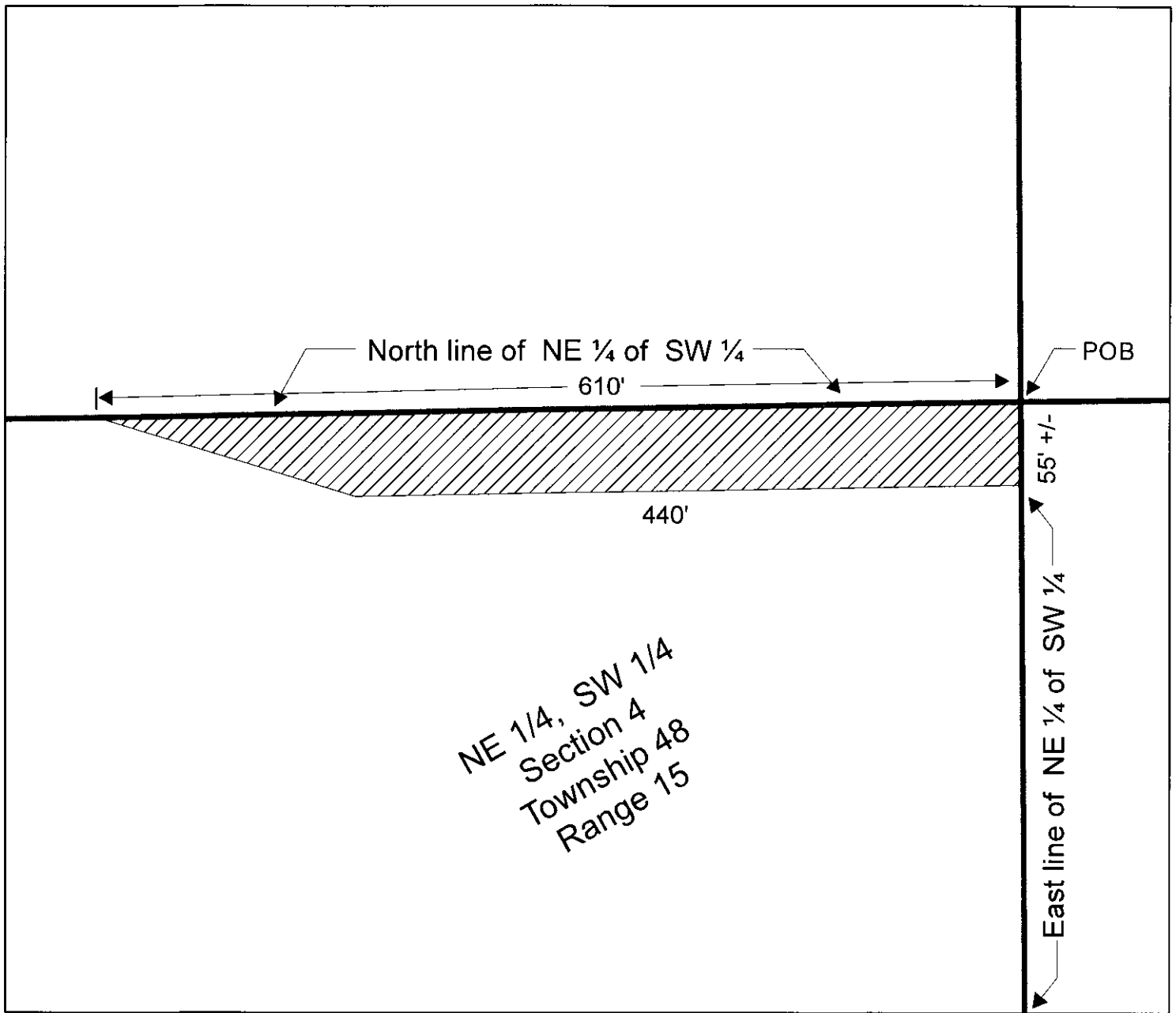

Easement Area



**Easement Area:**

Beginning at the Northeast corner of the Northeast 1/4 of the Southwest 1/4 of Section 4, Township 48, Range 15, St Louis County, Minnesota, thence southerly along the East line of said Northeast 1/4 of the Southwest 1/4 a distance of 55.00 feet more or less to a line that is parallel with and distant 55.00 feet southerly of the North line of said Northeast 1/4 of the Southwest 1/4; thence westerly along said parallel line a distance of 440.00 feet; thence northwesterly to a point on the North line of said Northeast 1/4 of the Southwest 1/4 that is 610.00 feet west of the Point of Beginning; thence easterly along said North line of said Northeast 1/4 of the Southwest 1/4 a distance of 610.00 feet to the Point of Beginning.

APPROVED BY CITY ENGINEER

8-4-21

DATE

# EXHIBIT A

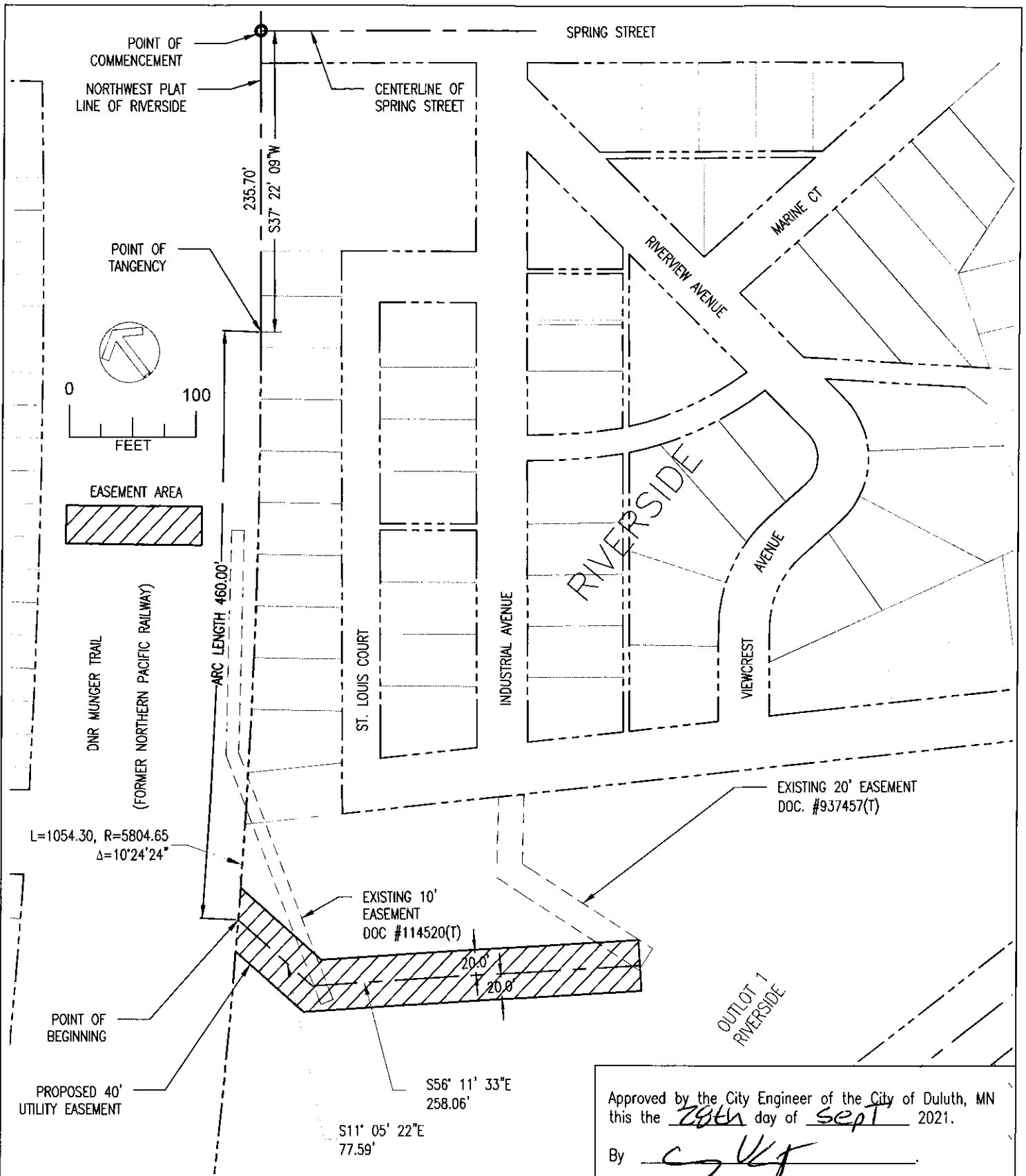

Approved by the City Engineer of the City of Duluth, MN  
 this the 28th day of sept 2021.

By [Signature]

GOGEBIC CREEK STORM SEWER EASEMENT

PROJECT #1769

PAGE 1 OF 2

I hereby certify that this plan, specification, or report was prepared by me or under my direct supervision and that I am a duly Licensed Land Surveyor under the laws of the State of Minnesota.

Greg Stoewer 21774 Sept. 28, 2021  
 License # Date

# EXHIBIT A

A 40.0 foot wide utility easement across that part of Outlot 1, Riverside, according to the plat of record in St. Louis County, Minnesota, center line of said easement is described as follows:

Commencing at the intersection with the northwest plat line of said Riverside, also being the southeast right of way of former Northern Pacific Railway, with the centerline of Spring Street as dedicated in said plat of Riverside; thence southwesterly along said northwest plat line 235.70 feet South 37 degrees 22 minutes 9 seconds West to a tangential curve that has arc length 1054.30 feet, curve radius 5804.65 feet and central angle of 10 degrees 24 minutes 24 seconds; thence southwesterly 460.00 feet along said curve of said northwest plat line, curve radius 5804.65 feet, concave to the northeast, to the point of beginning of said center line of easement; thence South 11 degrees 5 minutes 22 seconds East 77.59 feet; thence South 56 degrees 11 minutes 33 seconds East 258.06 feet and there said centerline terminating. Side lines of said 40.0 foot easement are prolonged or shortened to end on said northwest plat line. Basis of bearing is SLCTM 96.

Approved by the City Engineer of the City of Duluth, MN  
this the 20th day of Sept 2021.

By [Signature]

GOGEBIC CREEK STORM SEWER EASEMENT

PROJECT #1769

PAGE 2 OF 2

I hereby certify that this plan, specification, or report was prepared by me or under my direct supervision and that I am a duly Licensed Land Surveyor under the laws of the State of Minnesota.

[Signature]

Greg Stoewer

21774

License #

Sept. 28, 2021

Date

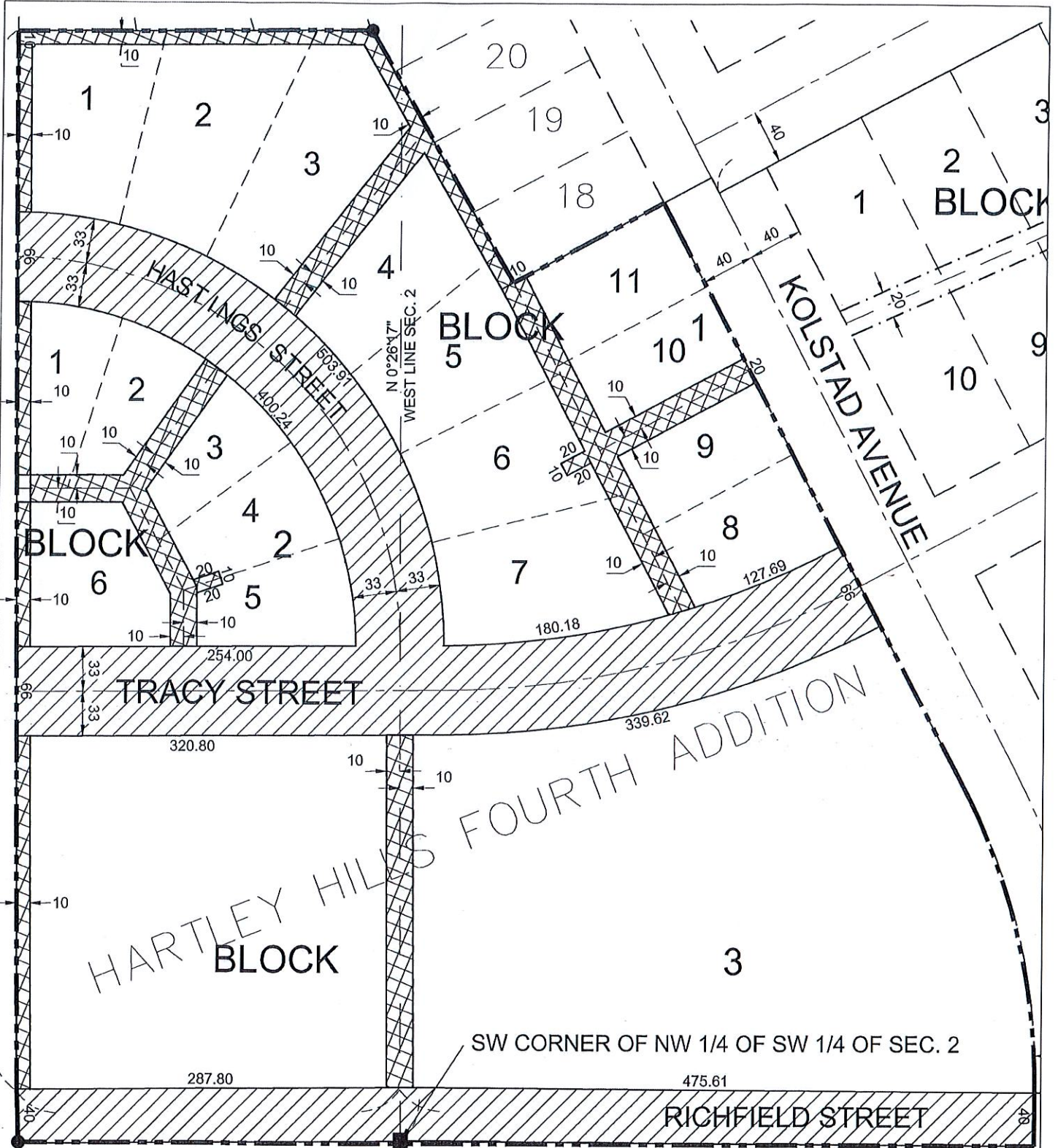

**EXHIBIT A**



HARTLEY HILLS FOURTH ADDITION

SW CORNER OF NW 1/4 OF SW 1/4 OF SEC. 2

**LEGEND**

-  PROPOSED RIGHT OF WAY VACATION
-  PROPOSED UTILITY EASEMENT VACATION

0 100'

ONE INCH

I hereby certify that this survey, plan or report was prepared by me or under my direct supervision and that I am a duly Licensed Land Surveyor under the laws of the State of Minnesota.

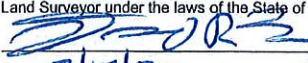

Date: 2/17/20 MN Lic. No: 49505

Approved by the City Engineer of the City of Duluth, MN this 17 day of Feb 2020

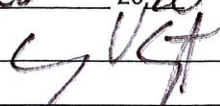
By 



## **VACATION OF UTILITY EASEMENT AND RIGHT OF WAY**

### **HARTLEY HILLS FOURTH ADDITION**

#### LEGAL DESCRIPTION OF PROPOSED UTILITY EASEMENT VACATION

All that part of the platted utility easements lying within the following described property:

Blocks 1, 2 AND 3, HARTLEY HILLS FOURTH ADDITION, according to the recorded plat thereof, St. Louis County, Minnesota.

Said proposed utility easement area to be vacated containing 33,693 square feet or 0.77 acres.

#### LEGAL DESCRIPTION OF PROPOSED RIGHT OF WAY VACATION

All of Hastings St. as dedicated on the plat of HARTLEY HILLS FOURTH ADDITION, according to the recorded plat thereof, St. Louis County, Minnesota.

AND

That part of Tracy Street contained within Blocks 1,2 AND 3 as dedicated on the plat of HARTLEY HILLS FOURTH ADDITION, according to the recorded plat thereof, St. Louis County, Minnesota, bounded on the West by the west line of said HARTLEY HILLS FOURTH ADDITION and bounded on the east by the southerly extension of the east line of Lot 8, Block 1 in said plat.

AND

That part of Richfield Street lying adjacent to Block 3 as dedicated on the plat of HARTLEY HILLS FOURTH ADDITION, according to the recorded plat thereof, St. Louis County, Minnesota, bounded on the West by the west line of said HARTLEY HILLS FOURTH ADDITION and bounded on the east by the southerly extension of the east line of Block 3 in said plat.

Said proposed right of way area to be vacated containing 102,959 square feet or 2.36 acres.

**APPENDIX H**  
**Drainage Report Submittal Checklist**



City of Duluth  
 department of public works/utilities  
 Engineering Division  
 211 City Hall · Duluth MN 55802  
 (218) 730-5200

**Drainage Report Submittal Check List** (include with Drainage Report)

**Project Name:** \_\_\_\_\_

**Owner / Developer:** \_\_\_\_\_

**Engineering Firm and Engineer:** \_\_\_\_\_

**Drainage Report Date:** \_\_\_\_\_ **Est. Construction Start Date:** \_\_\_\_\_

Drainage Report Document	Included	
	Yes	No
Cover Sheet - signed by engineer		
Drainage Report Submittal Check List		
Table of Contents		
Summary		
Summary tables of pre/post conditions -		
Pervious and impervious areas, discharge rates and volumes (2,10,100yr)		
Statement of project performance in context of UDC/Eng. Guidelines		
Narrative of Project		
Pre-Project Conditions		
Complete analysis of pre-conditions with exhibits		
Post-Project Conditions		
Complete analysis of post-conditions with exhibits		
Discussion of project's LID practices		
Discussion of site discharge: routing, Q, TOLV, TSS/TP, T		
BMP descriptions, details, function/routing		
SWPPP		
Exhibits/plan sheets		
Stormwater Management Facilities Operation and Maintenance Manual		
Preliminary O&M		
Plan Set 11x17		
Appendices		
Modeling output, exhibits, soil/geotechnical reports, other supporting documentation		
Supporting Documentation		

**APPENDIX I**  
**Preliminary Design Submittal Worksheet**





## City of Duluth

DEPARTMENT OF PUBLIC WORKS/UTILITIES

Engineering Division

211 City Hall • Duluth MN 55802

(218) 730-5200 Fax: (218) 730-5907

### PRELIMINARY DESIGN SUBMITTAL WORKSHEET AND MEETING

A preliminary storm water management design meeting is required for all projects that must meet the requirements of the UDC and Engineering Guidelines. This process allows for a discussion of the proposed development in the context the Community Drainage System and the temporary and permanent stormwater management requirements by the MPCA and the City of Duluth.

Date: \_\_\_\_\_ Date of Meeting: \_\_\_\_\_ Est. Project Start Date: \_\_\_\_\_

Project Name/Owner: \_\_\_\_\_

Project Location: \_\_\_\_\_

Engineering Firm/Engineer: \_\_\_\_\_

Project Narrative: (Include the scope of project and clearly describe predevelopment and post development site conditions. Discuss UDC requirements; water quality treatment, and discharge rate, volume and temperature controls. Discuss how project will consider Conservation/Low Impact Design Methods to the Maximum Extent Practical).

#### A Preliminary Site Plan (PSP) is required:

The PSP doesn't have to be CADD developed as long as it is clearly drawn showing a minimum of:

- \_\_\_\_\_ PSP to be on 11 x 17 sized sheets
- \_\_\_\_\_ Overall concept(s) of Development
- \_\_\_\_\_ Predevelopment site plan with existing utilities and roads, and topography
- \_\_\_\_\_ All existing and proposed catchment areas roughly delineated with flow arrows
- \_\_\_\_\_ NR-O Map (floodplain type, shoreland class and stormwater rate control zone)
- \_\_\_\_\_ All wetlands both delineated and potential areas shown
- \_\_\_\_\_ Show down gradient conveyance routes from site (property ownership, receiving waters...)

**APPENDIX J**  
**MS4 Statement of Compliance**



**APPENDIX K**  
**Example: City of Duluth – Plan Sheet – Title Page**

PLAN LEGEND

RIGHT OF WAY LINE	——— ——— ———
DITCH CENTERLINE	———x———
FENCE LINE	———x———
RETAINING WALL	———x———
GRAVEL LINE	———x———
GUARD RAIL LINE	———x———
RAILROAD TRACK LINE	———x———
ROAD CENTERLINE	———x———
TREE LINE	———x———
STREAM LINE	———x———
WETLAND LINE	———x———
EX SANITARY LINE	———x———
PR SANITARY LINE	———x———
AB SANITARY LINE	———x———
EX FORCEMAIN LINE	———x———
PR FORCEMAIN LINE	———x———
AB FORCEMAIN LINE	———x———
EX STORM LINE	———x———
PR STORM LINE	———x———
AB STORM LINE	———x———
EX WATER LINE	———x———
PR WATER LINE	———x———
AB WATER LINE	———x———
EX GAS LINE	———x———
PR GAS LINE	———x———
AB GAS LINE	———x———
EX STEAM LINE	———x———
PR STEAM LINE	———x———
UG CABLE TV LINE	———x———
AB CABLE TV LINE	———x———
UG ELECTRIC LINE	———x———
AB ELECTRIC LINE	———x———
UG FIBEROPTIC LINE	———x———
AB FIBEROPTIC LINE	———x———
UG TELEPHONE LINE	———x———
AB TELEPHONE LINE	———x———
OH ELECTRIC LINE	———x———
OH TELEPHONE LINE	———x———
OH CABLE TV LINE	———x———

SYMBOLS

EX SANITARY MANHOLE	(SAN)	⊗
EX SANITARY CLEANOUT	(STRM)	⊗
EX STORM MANHOLE	(STRM)	⊗
EX STORM CATCHBASIN	(STRM)	⊗
EX. WATER MANHOLE	(W)	⊗
EX. WATER VALVE	(W)	⊗
EX. WATER HYDRANT	(W)	⊗
EX. WATER SHUTOFF	(W)	⊗
EX. WATER & GAS MH	(W&G)	⊗
EX. GAS MANHOLE	(GAS)	⊗
EX. GAS VALVE	(GAS)	⊗
EX. GAS SHUTOFF	(GAS)	⊗
EX. STEAM MANHOLE	(STEAM)	⊗
EX. TELEPHONE MANHOLE	(T)	⊗
EX. ELECTRIC MANHOLE	(E)	⊗
EX. POWERPOLE	(E)	⊗
EX. LIGHT POLE	(E)	⊗
EX. ELECTRIC VAULT	(E)	⊗
EX. ANCHOR	(E)	⊗
EX. ELECTRIC TRANSFORMER	(ET)	⊗
EX. STREET LIGHT	(E)	⊗
EX. SIGNAL W/ STREET LIGHT	(E)	⊗
EX. HANDHOLE	(H.H.)	⊗
EX. HANDHOLE	(H.H.)	⊗
EX. TELEPHONE PEDESTAL	(E)	⊗
EX. WELL	(W)	⊗
BENCHMARK	(B)	⊗
FOUND CI MONUMENT	(F)	⊗
EX. SIGN	(S)	⊗
CONTROL POINT	(C)	⊗
EX DECIDUOUS TREE	(D)	⊗
EX CONIFEROUS TREE	(C)	⊗
EX. PARKING METER	(P)	⊗
EX. SOIL BORING	(SB)	⊗

# CITY OF DULUTH

## DEPARTMENT OF PUBLIC WORKS AND UTILITIES ENGINEERING DIVISION

### CONSTRUCTION PLANS FOR:

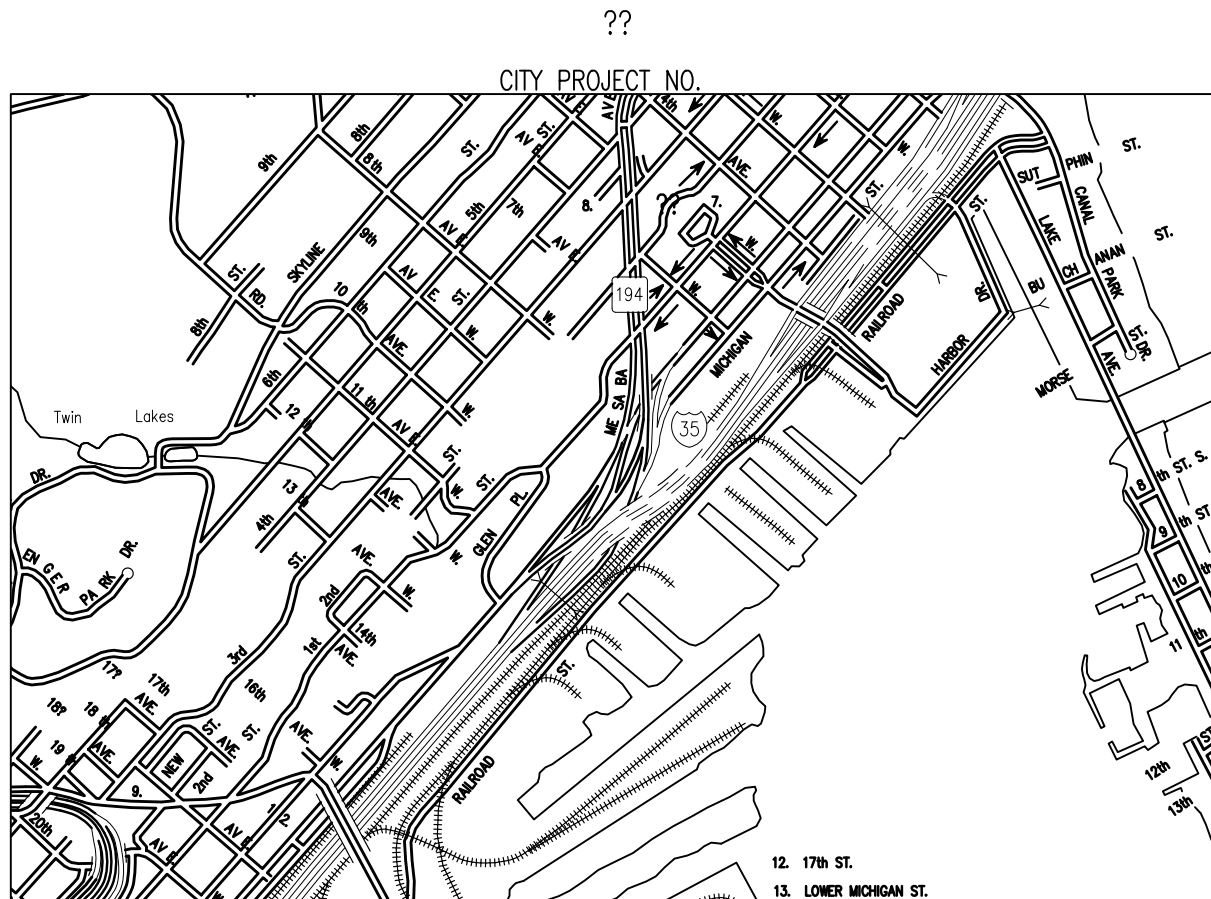

**BASIS OF DATUM**

- HORIZONTAL DATUM IS SAINT LOUIS COUNTY TRANSVERSE MERCATOR 1996 (SLCTM\_96)
- VERTICAL DATUM IS NAVD 88 USING VERTICAL CONTROL MONUMENT "XXXXXX" (EL=XXX.XXX').

**TRAFFIC CONTROL NOTE**

ALL TRAFFIC CONTROL DEVICES AND SIGNING SHALL CONFORM AND BE INSTALLED IN ACCORDANCE WITH THE CURRENT "MINNESOTA MANUAL ON UNIFORM TRAFFIC CONTROL DEVICES" (MnMUTCD), INCLUDING THE LATEST FIELD MANUAL FOR TEMPORARY TRAFFIC CONTROL ZONE LAYOUTS.

THE SUBSURFACE UTILITY INFORMATION IN THIS PLAN IS UTILITY LEVEL D. THIS QUALITY LEVEL WAS DETERMINED ACCORDING TO THE GUIDELINES OF CI/ASCE 38-02, ENTITLED "STANDARD GUIDELINES FOR THE COLLECTION AND DEPICTION OF EXISTING SUBSURFACE UTILITY DATA".

PLAN REVISIONS		
DATE	SHEET NO.	APPROVER

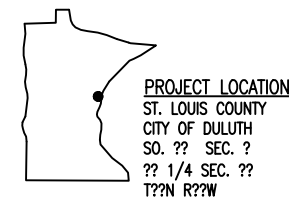

CITY OF DULUTH PROJECT NO. ??

**GOVERNING SPECIFICATIONS**

THE 2020 EDITION OF THE MINNESOTA DEPARTMENT OF TRANSPORTATION "STANDARD SPECIFICATIONS FOR CONSTRUCTION" SHALL GOVERN. AVAILABLE AT: <http://www.dot.state.mn.us/pre-letting/spec/index.html>

THE 2019 EDITION OF THE CITY OF DULUTH PUBLIC WORKS AND UTILITIES DEPARTMENT CONSTRUCTION STANDARDS AND SUPPLEMENTS OR ADDENDUMS SHALL APPLY.

AVAILABLE AT: <http://www.duluthmn.gov/engineering/standard-construction-specifications/>

**WARNING:**

LOCATION OF UNDERGROUND UTILITIES TO BE VERIFIED BY CONTRACTOR. CALL BEFORE DIGGING. GOPHER STATE ONE CALL 1-800-252-1166 REQUIRED BY LAW

**INDEX**

SHEET NO.	DESCRIPTION
1	TITLE SHEET

THIS PLAN CONTAINS ## SHEETS

DESIGN TEAM: X. XXXX, X. XXXX

I HEREBY CERTIFY THAT THIS PLAN WAS PREPARED BY ME OR UNDER MY DIRECT SUPERVISION AND THAT I AM A DULY LICENSED PROFESSIONAL ENGINEER UNDER THE LAWS OF THE STATE OF MINNESOTA.

PROJECT ENGINEER (TYPED OR PRINTED NAME)

PROJECT ENGINEER DATE LIC. NO.

CITY APPROVAL

APPROVED CHIEF ENGINEER OF TRANSPORTATION DATE

APPROVED CHIEF ENGINEER OF UTILITIES DATE

APPROVED CITY ENGINEER DATE

DRAWN BY: ??

SHEET NO. ?? OF ??

MINNESOTA DEPARTMENT OF TRANSPORTATION  
 CITY OF DULUTH  
 DEPARTMENT OF PUBLIC WORKS AND UTILITIES  
 ENGINEERING DIVISION

CONSTRUCTION PLANS FOR: XXX, XXX, XXXXX

LOCATED ON: XXXX FROM XXX TO XXXX

STATE AID PROJ. NO. XXX-XXX-XXX  
 GROSS LENGTH    XXXX FEET   XXXX MILES  
 BRIDGES-LENGTH    FEET    MILES  
 EXCEPTIONS-LENGTH   FEET    MILES  
 NET LENGTH        XXX.X FEET   X.XXX MILES

A POINT APPROX. XXXX' EAST AND  
 XXXX' NORTH OF THE S.W. CORNER  
 OF SEC. X, T XX N, R XX W

TO

A POINT APPROX. XXX' WEST AND  
 XXX' NORTH OF THE S.E. CORNER  
 OF SEC. X, T XX N, R XX W

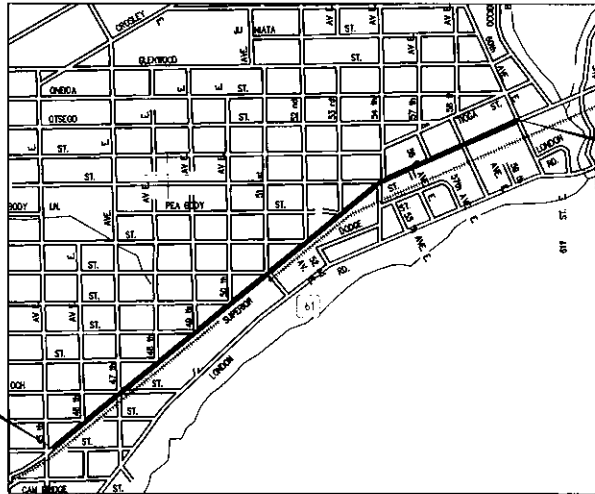

STA. XX+XX.0  
 END CONSTRUCTION  
 SP XXX-XXX-XXX  
 CITY PROJ. NO. XXXX

STA. XX+XX.X  
 BEGIN CONSTRUCTION  
 SP XXX-XXX-XXX  
 CITY PROJ. NO. XXXX

DESIGN DESIGNATION  
 STATE AID PROJECT NO. XXX-XXX-XXX  
 P-VALUE .....XX.....    FINISH .....MA.....  
 ADT (CURRENT YEAR)   20XX = XXXX  
 ADT (FUTURE YEAR)   20XX = XXXX  
 D (DIRECTIONAL DIST.) = XX/XX  
 T (HEAVY COMMERCIAL) = XX  
 DESIGN SPEED    XX MPH  
 BASED ON STOPPING SIGHT DISTANCE  
 HEIGHT OF EYE 3.5'   HEIGHT OF OBJECT 2.0'

**BASIS OF DATUM**

- HORIZONTAL DATUM IS SAINT LOUIS COUNTY TRANSVERSE MERCATOR 1995 (SLCTM\_96)
- VERTICAL DATUM IS NAVD 88 USING VERTICAL CONTROL MONUMENT "XXXXXX" (EL=XXX.XXX).

**TRAFFIC CONTROL NOTE**  
 ALL TRAFFIC CONTROL DEVICES AND SIGNING SHALL CONFORM  
 AND BE INSTALLED IN ACCORDANCE WITH THE CURRENT  
 "MINNESOTA MANUAL ON UNIFORM TRAFFIC CONTROL DEVICES"  
 (MUTCD), INCLUDING THE LATEST FIELD MANUAL FOR  
 TEMPORARY TRAFFIC CONTROL ZONE LAYOUTS.

PLAN REVISIONS		
DATE	SHEET NO.	APPROVER

**WARNING:**  
 LOCATION OF UNDERGROUND UTILITIES TO BE VERIFIED BY  
 CONTRACTOR. CALL BEFORE DIGGING. Gopher STATE ONE CALL  
 1-800-252-1156 REQUIRED BY LAW

**SCALES**  
 PLAN        XX'  
 INDEX MAP   XXXX'  
 ADA PLAN    XX' XX'



STATE AID PROJECT NUMBER - SP XXX-XXX-XXX      CITY PROJECT NUMBER XXXX      SHEET NO. 1 OF XXX

MINN PROJECT NO STPF 6921 (223)

**GOVERNING SPECIFICATIONS**

THE 2020 EDITION OF THE MINNESOTA DEPARTMENT OF TRANSPORTATION  
 "STANDARD SPECIFICATIONS FOR CONSTRUCTION" SHALL GOVERN. AVAILABLE  
 AT:  
<http://www.dot.state.mn.us/pre-letting/spec/index.html>

THE 2019 EDITION OF THE CITY OF DULUTH PUBLIC WORKS AND UTILITIES  
 DEPARTMENT CONSTRUCTION STANDARDS AND SUPPLEMENTS OR ADDENDUMS  
 SHALL APPLY.  
 AVAILABLE AT:  
<http://www.duluthmn.gov/engineering/standard-construction-specifications/>

THE SUBSURFACE UTILITY INFORMATION IN THIS PLAN IS UTILITY LEVEL C.  
 THIS QUALITY LEVEL WAS DETERMINED ACCORDING TO THE GUIDELINES OF  
 C/ASCE 38-02, ENTITLED "STANDARD GUIDELINES FOR THE COLLECTION AND  
 DEPICTION OF EXISTING SUBSURFACE UTILITY DATA".

**INDEX**

SHEET NO.	DESCRIPTION
1	TITLE SHEET
2	LEGEND & GENERAL NOTES
X-XX	XXXXX

THIS PLAN CONTAINS XXX SHEETS

**DESIGN TEAM**

X. XXXXX, X. XXXXXXX

I HEREBY CERTIFY THAT THIS PLAN WAS PREPARED BY ME OR UNDER MY  
 DIRECT SUPERVISION AND THAT I AM A DULY LICENSED PROFESSIONAL  
 ENGINEER UNDER THE LAWS OF THE STATE OF MINNESOTA.

XXX X. XXXX

PROJECT ENGINEER (TYPED OR PRINTED NAME)

PROJECT ENGINEER      XX-XX-XXXX      XXXX  
 DATE      LIC. NO.  
**CITY APPROVAL**

APPROVED      CHIEF ENGINEER OF TRANSPORTATION      DATE

APPROVED      CHIEF ENGINEER OF UTILITIES      DATE

APPROVED      CITY ENGINEER      DATE  
**STATE APPROVAL**

DISTRICT STATE AID ENGINEER: REVIEWED FOR COMPLIANCE      DATE  
 WITH STATE-AID AND FEDERAL AID RULES/POLICY

APPROVED FOR FEDERAL AID FUNDING: STATE AID ENGINEER      DATE

3/17/2022 2:09 PM

I:\PW\ENGINEER\LOAD STANDARDS\STANDARD SHEETS\2022-SA-UPDATE\CODL\_SHEET

PLAN LEGEND

Table listing various utility and site features with their corresponding line styles and symbols, including Right of Way Line, Ditch Centerline, Fence Line, Retaining Wall, Gravel Line, Guard Rail, Railroad Track, Tree Line, Stream Flow Line, Wetland Limit, Lakeshore, and various sewer, water, gas, and steam lines (both existing and proposed).

ABBREVIATIONS USED IN THIS PLAN

- AB = ABANDONED
REM = REMOVE
EX = EXISTING OR IN-PLACE
PR = PROPOSED
UG = UNDERGROUND
OH = OVERHEAD
PL = PLACE

GENERAL REQUIREMENTS

- 1. WITHIN THE PLAN WHEREVER THE WORD "INCIDENTAL" IS USED, IT SHALL MEAN NO DIRECT PAYMENT WILL BE MADE FOR THAT ITEM.
2. WHENEVER THE PHRASE "MIN." IS USED IN THIS PLAN, IT SHALL MEAN THE WORD MINIMUM.
3. PLACE 1/2" BIT FELT (FULL HEIGHT) AT ALL JOINTS WHERE PROPOSED CONCRETE DRIVEWAYS AND SIDEWALKS MEET EXISTING CONCRETE DRIVEWAYS, SIDEWALKS, OR RETAINING WALLS.
4. ALL AREAS DISTURBED BY THE CONTRACTORS EQUIPMENT WHICH ARE OUTSIDE THE PLANNED CONSTRUCTION LIMITS SHALL BE RESTORED, AS APPROVED BY THE ENGINEER, AT THE CONTRACTOR'S EXPENSE.
5. BITUMINOUS SURFACING, CONCRETE ITEMS, ABANDONED UTILITY ITEMS, OR ANY OTHER MATERIAL WHICH MAY BE ENCOUNTERED DURING CONSTRUCTION THAT ARE NOT SUITABLE FOR SALVAGE OR FOR ROADWAY CONSTRUCTION SHALL BE DISPOSED OF BY THE CONTRACTOR AT AN APPROVED DISPOSAL SITE AND SHALL BE INCIDENTAL.
6. THE CONTRACTOR SHALL PROVIDE A CONCRETE WASHOUT AND WASHOUT LOCATION AND CONTAINER ON THE PROJECT AND IT SHALL BE APPROVED BY THE ENGINEER PRIOR TO THE RELATED WORK. THE CONTRACTOR SHALL MAINTAIN THE CONTAINER AND DISPOSE OF ITS CONTENTS IN ACCORDANCE WITH MPCA REQUIREMENTS. THIS WORK SHALL BE CONSIDERED INCIDENTAL. FOR WHICH NO DIRECT COMPENSATION SHALL BE MADE.
7. THE CONTRACTOR IS ADVISED THAT THERE SHALL BE NO STOCKPILING OF MATERIALS ON SITE OUTSIDE THE PROJECT CONSTRUCTION LIMITS, UNLESS OTHERWISE NOTED.
8. BITUMINOUS TONNAGE COMPUTED AT 120 LBS/SQ YD/INCH OF THICKNESS.
9. THE RIGHT-OF-WAY SHOWN IN THIS PLAN IS GRAPHICAL AND BASED UPON THE CITY OF DULUTH GIS.
10. CARE SHALL BE TAKEN BY THE CONTRACTOR SO AS NOT TO DAMAGE THE REMAINING MATERIALS DIRECTLY ADJACENT TO THE MATERIALS TO BE REMOVED.
11. ANY DAMAGE TO THE EXISTING MATERIAL RESULTING FROM THE MATERIAL REMOVAL OPERATIONS SHALL BE REPAIRED AT THE CONTRACTOR'S EXPENSE.
12. ALL LAYOUT ASSOCIATED WITH REMOVAL & CONSTRUCTION OF PEDESTRIAN RAMPS, SIDEWALK AND CURB & GUTTER SHALL BE DONE BY THE CONTRACTOR. THE CONTRACTOR SHALL PROTECT AND RESTRICT USE OF PEDESTRIAN RAMPS UNTIL THEY CAN BE USED SAFELY AND SUPPLY A SAFE ROUTE FOR PEDESTRIANS DURING CONSTRUCTION AND COMPLY WITH THE LATEST TEMPORARY TRAFFIC CONTROL FIELD MANUAL. REFER TO THE SPECIAL PROVISIONS FOR ADDITIONAL REQUIREMENTS. (INCIDENTAL)

NOTES

SURVEYS AND RIGHT OF WAY

THE CONTRACTOR SHALL PRESERVE ALL LAND AND PROPERTY CORNERS, VERTICAL & HORIZONTAL CONTROLS, SURVEY AND RIGHT OF WAY MONUMENTS. THE RIGHT OF WAY SHOWN IN THIS PLAN GIVES A GRAPHICAL LOCATION WITH RESPECT TO THE PLAN ALIGNMENTS. FOR EXACT RIGHT OF WAY LIMITS, SEE MAP ON FILE WITH THE CITY OF DULUTH.

DRAINAGE

PIPE ELEVATIONS, OFFSETS, AND COORDINATES AS SHOWN IN THE PLAN, ARE TO THE CENTER OF THE STRUCTURE..

THE FOLLOWING UTILITY OWNERS HAVE ASSETS ON THIS PROJECT.

Table listing utility owners, their marking codes, and damage codes. Includes Charter Communications, City of Duluth - Engineering/Traffic, Duluth Energy Systems, Lumen Technologies, Duluth N Shore Sanitary Dist, Consolidated Communications, Minnesota Power, Northeast Service Cooperative, St Mary's Duluth Clinic Health, and Western Lake Superior Sanitary.

PLAN SYMBOLS

Table listing various symbols used in the plan, such as EX SANITARY MANHOLE, EX SANITARY CLEANOUT, EX STORM MANHOLE, EX STORM CATCHBASIN, EX WATER MANHOLE, EX WATER VALVE, EX WATER HYDRANT, EX WATER SHUTOFF, EX WATER & GAS MH, EX GAS MANHOLE, EX GAS VALVE, EX GAS SHUTOFF, EX STEAM MANHOLE, EX TELEPHONE MANHOLE, EX ELECTRIC MANHOLE, EX UTILITY POLE, EX LIGHT POLE, EX ELECTRIC VAULT, EX GUY ANCHOR, EX ELECTRIC TRANSFORMER, EX STREET LIGHT, EX SIGNAL W/STREET LIGHT, EX HAND HOLE, EX TELEPHONE PEDESTAL, EX WELL, EX SIGN, EX DECIDUOUS TREE, EX CONIFEROUS TREE, EX PARKING METER, BENCHMARK, CONTROL POINT, FOUND CI MONUMENT, and SOIL BORING.

I HEREBY CERTIFY THAT THIS PLAN WAS PREPARED BY ME OR UNDER MY DIRECT SUPERVISION AND THAT I AM A DULY LICENSED PROFESSIONAL ENGINEER UNDER THE LAWS OF THE STATE OF MINNESOTA.

SIGNATURE: \_\_\_\_\_ TYPE NAME

DATE: // //

LIC. NO.: // //



CITY OF DULUTH ENGINEERING DIVISION 411 W. 1ST ST. STE. 211 DULUTH, MN 55802

XXXXXXXXXXXXXXXXXXXX

CITY PROJECT NO.: // //

STATE AID PROJECT NO.: // //

DRAWN BY: // //

DATE: // //

SHEET NO. // // OF // //

**APPENDIX L**  
**Water Main Check-off List**



# City of Duluth Public Works & Utilities

## WATER MAIN PROJECT CHECK-OFF LIST

1/1/2019

---

Project Title/Location: \_\_\_\_\_

City Project Number: \_\_\_\_\_ Inspector: \_\_\_\_\_

### MAINS

1. Water mains passed bacteriological test  
Date \_\_\_\_\_ Inspected by \_\_\_\_\_
2. Water mains passed pressure test  
Date \_\_\_\_\_ Inspected by \_\_\_\_\_
3. Tracer wire installed and continuity test completed, if HDPE  
Date \_\_\_\_\_ Inspected by \_\_\_\_\_
4. Survey shots taken as required by the current Engineering Guidelines  
Date \_\_\_\_\_ Inspected by \_\_\_\_\_

### CURB BOXES

5. Water curb boxes adjusted to grade  
Date \_\_\_\_\_ Inspected by \_\_\_\_\_
6. Building ties and street ties taken  
Date \_\_\_\_\_ Inspected by \_\_\_\_\_

### HYDRANTS

7. Hydrants installed to current Engineering Standards  
Date \_\_\_\_\_ Inspected by \_\_\_\_\_

**APPENDIX M**  
**Water Valve, Hydrant Valve, Hydrant and Service Installation Records**

# City of Duluth Public Works & Utilities

## HYDRANT INSTALLATION RECORD

1/1/2019

HYDRANT NUMBER (City supplied)		DATE	
CITY PROJECT NUMBER		INSPECTOR	
PROJECT TITLE/ LOCATION			

**LOCATION OF HYDRANT MUST BE PROVIDED THROUGH BOTH OF THE FOLLOWING:**

•		<b>GPS HYDRANT LOCATION</b> Survey data must be provided in the form of an electronic CSV file.			
•		<b>TAPED OUT HYDRANT MEASUREMENTS</b> Measurement from road centerline must be included.			
	TIES			of the centerline of	ST/AVE
	TIES			of the centerline of	ST/AVE
	TIES			of the centerline of	ST/AVE

**ADDITIONAL REQUIRED INFORMATION**

<ul style="list-style-type: none"> <li>• Manufacturer (check one)                     <ul style="list-style-type: none"> <li><input type="checkbox"/> Watrous</li> <li><input type="checkbox"/> Mueller</li> </ul> </li> <li>• Model (check one)                     <ul style="list-style-type: none"> <li><input type="checkbox"/> Pacer WB 67 250</li> <li><input type="checkbox"/> Super Centurion 250</li> </ul> </li> </ul>	<ul style="list-style-type: none"> <li>• Weep hole plugged? (check one)                     <ul style="list-style-type: none"> <li><input type="checkbox"/> Yes *Affix sticker if plugged</li> <li><input type="checkbox"/> No</li> </ul> </li> <li>• Height of nozzle _____ (feet)</li> <li>• Main to hydrant _____ (feet)</li> <li>• Valve to hydrant _____ (feet)</li> <li>• Bury depth _____ (feet)</li> </ul>
---	--

HYDRANT VALVE INSTALLATION RECORD FORM FILLED OUT  YES  NO

**Remarks:**

# City of Duluth Public Works & Utilities

## HYDRANT VALVE INSTALLATION RECORD

1/1/2019

VALVE NUMBER (City supplied)		DATE	
CITY PROJECT NUMBER		INSPECTOR	
PROJECT TITLE/ LOCATION			

**LOCATION OF VALVE MUST BE PROVIDED THROUGH BOTH OF THE FOLLOWING:**

•	<b>GPS VALVE LOCATIONS</b>	Survey data must be provided in the form of an electronic CSV file.		
•	<b>TAPED OUT VALVE MEASUREMENTS</b>	Measurement from road centerline must be included.		
	TIES		of the centerline of	
				ST/AVE
	TIES		of the centerline of	
				ST/AVE
	TIES		of the centerline of	
				ST/AVE

**ADDITIONAL REQUIRED INFORMATION**

<ul style="list-style-type: none"> <li>• Valve size _____ (inches)</li> <li>• Manufacturer/Model (check one)                             <table style="width: 100%; margin-left: 20px;"> <tr> <td>_____ Kennedy</td> <td>_____ McWain</td> </tr> <tr> <td>_____ Clow</td> <td>_____ Mueller</td> </tr> <tr> <td>_____ M &amp; H</td> <td>_____ American Flow Control</td> </tr> </table> </li> <li>• Valve Type (check one)                             <table style="width: 100%; margin-left: 20px;"> <tr> <td>_____ Gate</td> </tr> <tr> <td>_____ Butterfly</td> </tr> </table> </li> </ul>	_____ Kennedy	_____ McWain	_____ Clow	_____ Mueller	_____ M & H	_____ American Flow Control	_____ Gate	_____ Butterfly	<ul style="list-style-type: none"> <li>• Valve closes clockwise (check one)                             <table style="width: 100%; margin-left: 20px;"> <tr> <td>_____ Yes</td> </tr> <tr> <td>_____ No</td> </tr> </table> </li> <li>• Number of turns to close _____</li> <li>• Valve left open (check one)                             <table style="width: 100%; margin-left: 20px;"> <tr> <td>_____ Yes</td> </tr> <tr> <td>_____ No</td> </tr> </table> </li> </ul>	_____ Yes	_____ No	_____ Yes	_____ No
_____ Kennedy	_____ McWain												
_____ Clow	_____ Mueller												
_____ M & H	_____ American Flow Control												
_____ Gate													
_____ Butterfly													
_____ Yes													
_____ No													
_____ Yes													
_____ No													

**Remarks:**

# City of Duluth Public Works & Utilities

## WATER SERVICE INSTALLATION RECORD

1/1/2019

VALVE NUMBER (City supplied)		DATE	
CITY PROJECT NUMBER		INSPECTOR	
PROJECT TITLE/ LOCATION			

### WATER SERVICE INFORMATION

WATER SERVICE SIZE		MATERIAL	
ADDRESS			
CONTRACTOR		SEWER IN TRENCH?	
LENGTH OF SERVICE		INSULATED?	
DEPTH AT CURB		LEAST DEPTH	
SIZE OF MAIN		LOCATION OF MAIN (STREET NAME)	

### TAPED OUT MEASUREMENTS (BUILDING TIES) ARE REQUIRED:

SHUTOFF TIES (1)		FT OUT FROM BLDG	TIES ARE OFF		LINE OF BLDG
SHUTOFF TIES (2)		FT		FROM	LINE OF BUILDING
DISTANCE FROM CENTER OF STREET TO SHUTOFF					FT (required)
DISTANCE FROM CENTER OF CROSS ST TO SHUTOFF					FT (required)

**Remarks:**

# City of Duluth Public Works & Utilities

## WATER VALVE INSTALLATION RECORD

1/1/2019

VALVE NUMBER (City supplied)		DATE	
CITY PROJECT NUMBER		INSPECTOR	
PROJECT TITLE/ LOCATION			

**LOCATION OF VALVE MUST BE PROVIDED THROUGH BOTH OF THE FOLLOWING:**

•	<b>GPS VALVE LOCATIONS</b>	Survey data must be provided in the form of an electronic CSV file.		
•	<b>TAPED OUT VALVE MEASUREMENTS</b>	Measurement from road centerline must be included.		
	TIES			of the centerline of <span style="float: right;">ST/AVE</span>
	TIES			of the centerline of <span style="float: right;">ST/AVE</span>
	TIES			of the centerline of <span style="float: right;">ST/AVE</span>

**ADDITIONAL REQUIRED INFORMATION**

<ul style="list-style-type: none"> <li>• Valve size _____ (inches)</li> <li>• Manufacturer/Model (check one)                             <table style="width: 100%; margin-left: 20px;"> <tr> <td>_____ Kennedy</td> <td>_____ McWain</td> </tr> <tr> <td>_____ Clow</td> <td>_____ Mueller</td> </tr> <tr> <td>_____ M &amp; H</td> <td>_____ American Flow Control</td> </tr> </table> </li> <li>• Valve Type (check one)                             <table style="width: 100%; margin-left: 20px;"> <tr> <td>_____ Gate</td> </tr> <tr> <td>_____ Butterfly</td> </tr> </table> </li> </ul>	_____ Kennedy	_____ McWain	_____ Clow	_____ Mueller	_____ M & H	_____ American Flow Control	_____ Gate	_____ Butterfly	<ul style="list-style-type: none"> <li>• Valve closes clockwise (check one)                             <table style="width: 100%; margin-left: 20px;"> <tr> <td>_____ Yes</td> </tr> <tr> <td>_____ No</td> </tr> </table> </li> <li>• Number of turns to close _____</li> <li>• Valve left open (check one)                             <table style="width: 100%; margin-left: 20px;"> <tr> <td>_____ Yes</td> </tr> <tr> <td>_____ No</td> </tr> </table> </li> </ul>	_____ Yes	_____ No	_____ Yes	_____ No
_____ Kennedy	_____ McWain												
_____ Clow	_____ Mueller												
_____ M & H	_____ American Flow Control												
_____ Gate													
_____ Butterfly													
_____ Yes													
_____ No													
_____ Yes													
_____ No													

**Remarks:**

**APPENDIX N**  
**Duluth Sanitary Sewer Wye Record**

# City of Duluth Public Works & Utilities

## SANITARY SEWER WYE RECORD

1/1/2019

WYE NUMBER (City supplied)		DATE	
CITY PROJECT NUMBER		INSPECTOR	
PROJECT TITLE/ LOCATION			

### SANITARY WYE INFORMATION

ADDRESS (must provide if available)					
PARCEL ID NUMBER( if address not available)					
LOT		BLOCK		SUBDIVISION	
MAIN LINE NUMBER (if known)			MAIN SIZE		MAIN MATERIAL
LOCATION OF MAIN					SIDE OF MAIN
*Add remarks if connected to existing brick arch					INTO MANHOLE?
WYE MATERIAL		WYE SIZE		LOCATING WIRE	

**LOCATION OF SANITARY SEWER WYE MUST BE PROVIDED THROUGH ONE OF THE FOLLOWING:**

- **GPS VALVE LOCATIONS** Survey data must be provided in the form of an electronic CSV file.
- **TAPED OUT VALVE MEASUREMENTS** Measurement from road centerline must be included.

Distance to Downstream Manhole		feet	from manhole number	
Distance to Upstream Manhole		feet	from manhole number	

**Remarks:**